



Applies To: 1998–99 Passport – All

February 4, 2014

MIL Comes On With DTC P1441

(Supersedes 00-011, dated July 26, 2011; see REVISION SUMMARY)

REVISION SUMMARY

The tools needed to diagnose and update the PCM for this vehicle are no longer supported and have been deleted from this bulletin. Some generic scan tools may still work.

SYMPTOM

The MIL comes on and DTC P1441 (EVAP System Flow During Non-Purge) is set.

POSSIBLE CAUSE

The PCM software does not compensate for signal variation in the fuel tank pressure sensor when fuel sloshes in a nearly full fuel tank.

CORRECTIVE ACTION

Replace the 20-to-120-ohm fuel sending unit with an 80-to-290-ohm unit if needed.

WARRANTY CLAIM INFORMATION

None. The customer is responsible for paying for any repairs.

SOFTWARE UPDATE INFORMATION

AHM no longer supports the tools required to update the software in the PCM. To update the PCM, you will have to send it to Par Tech; call 248-276-0213 for instructions on how to get the vehicle's PCM updated and the current cost.

PARTS INFORMATION

Fuel Sending Unit Kit:

P/N 8-25325-073-0, H/C 6258024

Kit contains two 80-to-290-ohm sending units (one with a small connector, the other with a large connector), an O-ring, a black locking clip, and a red locking clip.

You will also need these clips if you break the original clips while removing or installing the fuel lines:

Fuel Line Retaining Clip, 5/16":

P/N 2-90442-800-0

Fuel Line Retaining Clip, 3/8":

P/N 2-90442-810-0

REQUIRED MATERIALS

ProHonda Non-Chlorinated Brake Cleaner:

P/N 08732-9001

(One container will clean about two vehicles.)

REPAIR PROCEDURE

- Using a generic scan tool, retrieve any PCM broadcast codes and compare them to the codes listed here:

PCM Broadcast Codes (for 20-to-120-ohm fuel sending units):

BXBB, BXBC, BXBD, BXBF

CKMA, CKMB

CMWZ

CMXA, CMXB, CMXC

CMZA, CMZB, CMZC

- If the code *is not* listed, the vehicle has the current 80-to-290-ohm fuel sending unit. Go to step 32.
- If the code *is* listed, the vehicle has the original 20-to-120-ohm fuel sending unit. This unit *must* be replaced with the 80-to-290-ohm unit. Go to step 2.

2. Write down your customer's radio station presets and mode settings (treble, bass, balance, and fader).
 3. Note the reading on the fuel gauge, then disconnect the negative cable from the battery.
 4. Remove the fuel fill cap.
- NOTE: Wear proper eye protection through step 28 of this procedure.
5. If the fuel tank is more than 1/2 full, drain or siphon the fuel into a suitable container.
 6. Raise the vehicle on a lift. Support the fuel tank with a powertrain lift or a commercially available jack as shown in the illustrations. The powertrain lift, model No. OTC-1585, is available through the Honda Tool and Equipment Program.
 7. Disconnect the EVAP hose, the fuel filler vent hose, and the fuel filler hose where they connect to the fittings at the back of the fuel tank.

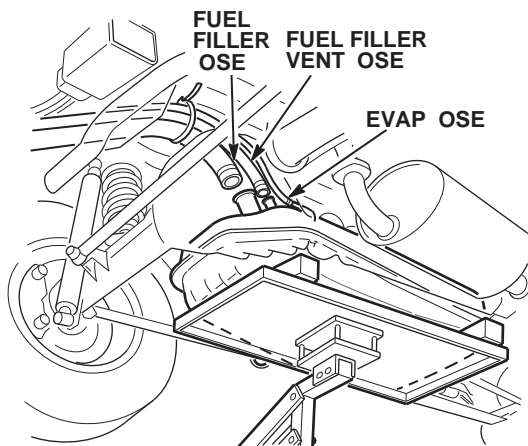

8. At the front of the tank, disconnect the fuel feed hose and the fuel return hose where they connect to the fuel filter and the fuel line. Remove the hoses from the support clip. Plug the hoses, and cap the lines to prevent any fuel leakage.

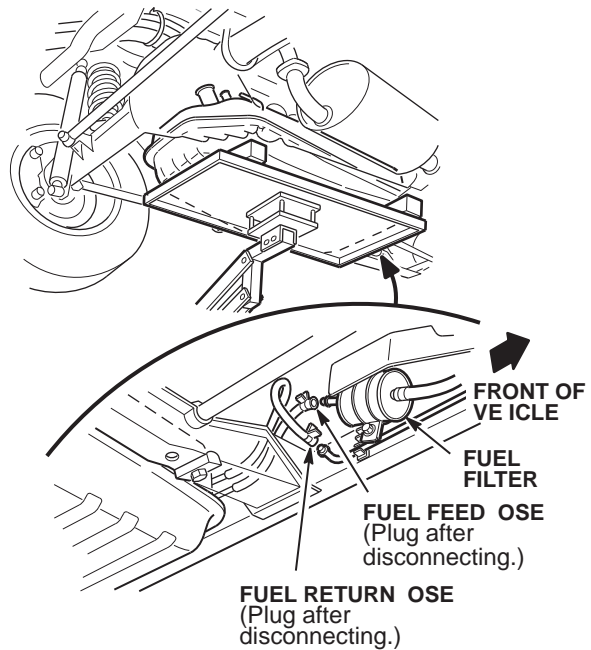

9. Remove the nuts and bolts from the corners of the tank. Do not remove the bolts from the skid plate.

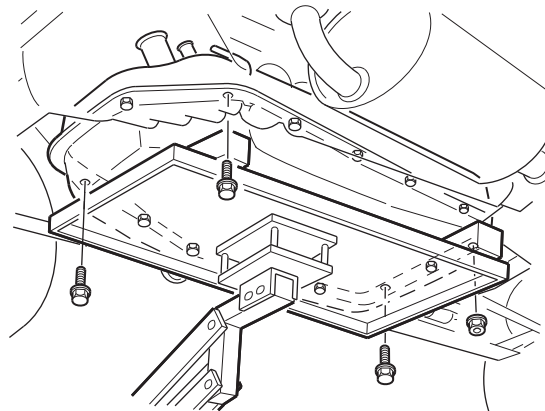

10. Partially lower the tank, then unplug the fuel pump/sending unit harness and the fuel tank pressure sensor harness.

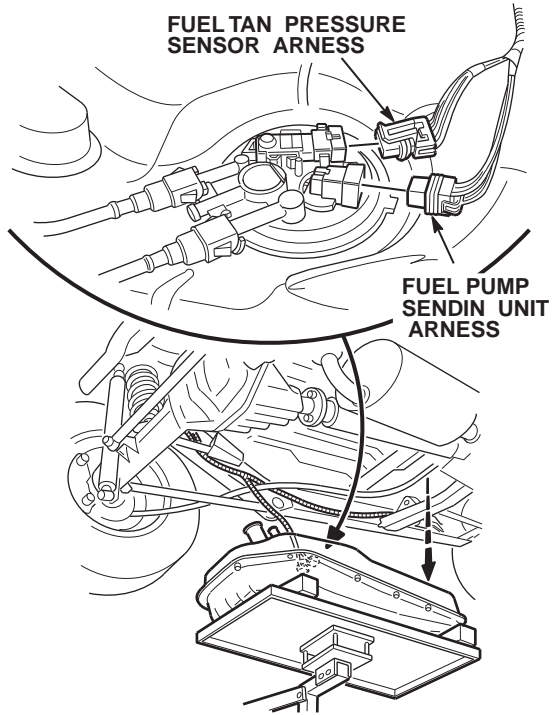

11. Use brake cleaner and compressed air to thoroughly clean the fuel pump and surrounding area.

12. Carefully remove the fuel feed hose and the fuel return hose from the fuel pump. Do *not* use too much force on the fuel line retaining clips or you may break them. Make sure you replace any broken clips. Remove the tank from the vehicle.

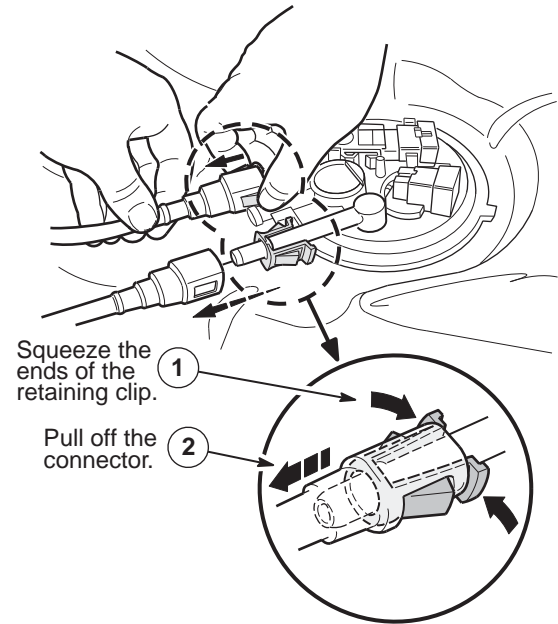

13. Use snap ring pliers to remove the fuel pump snap ring. Before you remove the pump, use brake cleaner and compressed air to clean the area around it.

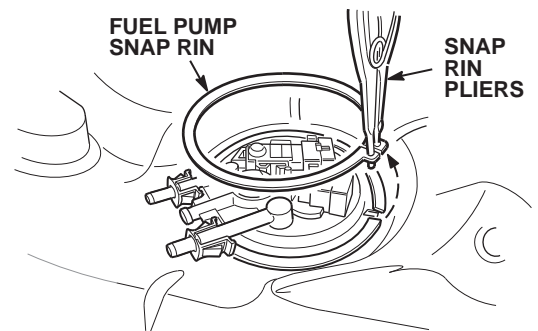

14. Remove the fuel pump assembly. To prevent damage to the float arm, lift the assembly straight up, and rotate it to the right.

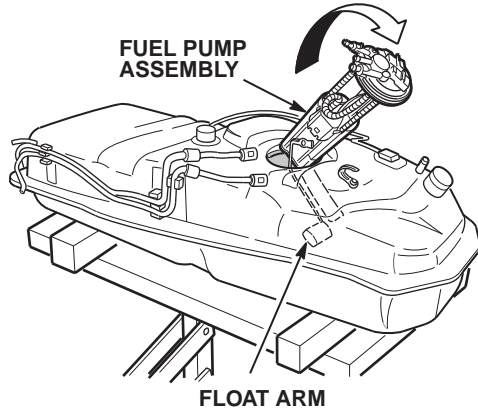

15. Insert a small screwdriver under the float arm at the brass bushing, and carefully pry the float arm out of the sending unit. Do *not* bend the arm.

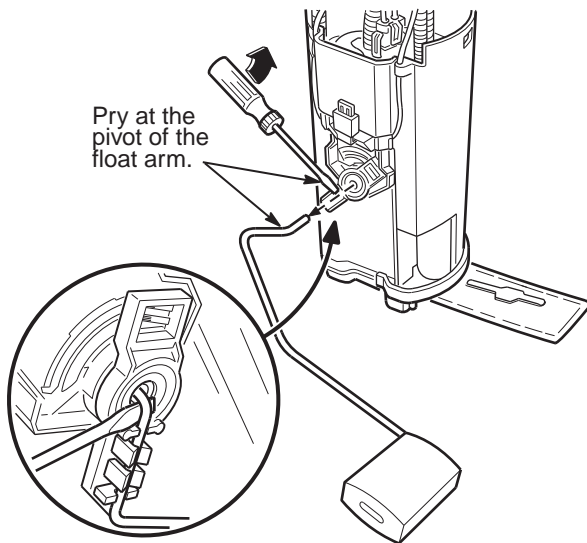

16. Remove the sending unit from the fuel pump assembly:

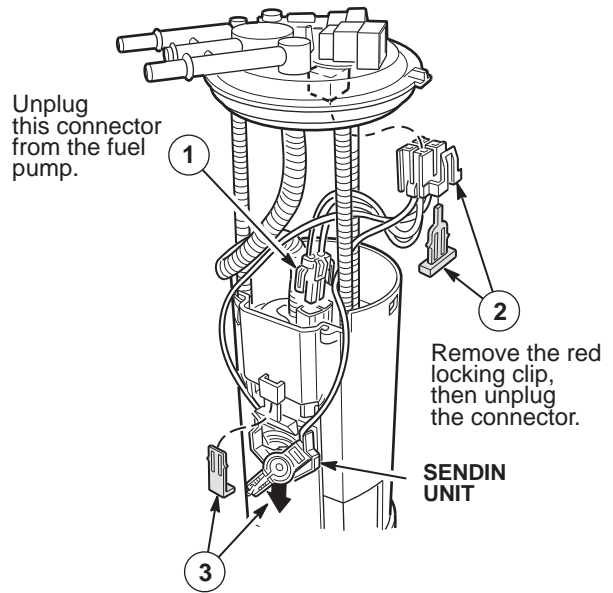

Remove the black locking clip, then remove the sending unit from the housing.

17. Remove the O-ring from the top of the pump assembly, and clean the O-ring seat. Lubricate the new O-ring with engine oil, and install the O-ring on the pump.

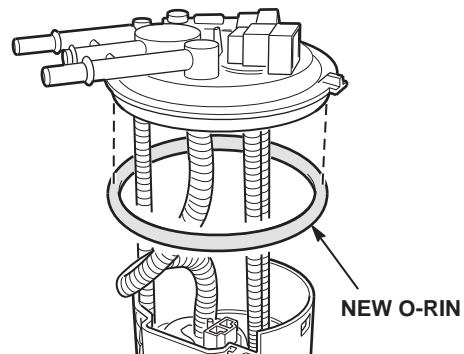

18. Of the two sending units in the kit, select the one with the connector that matches the connector from the original sending unit.

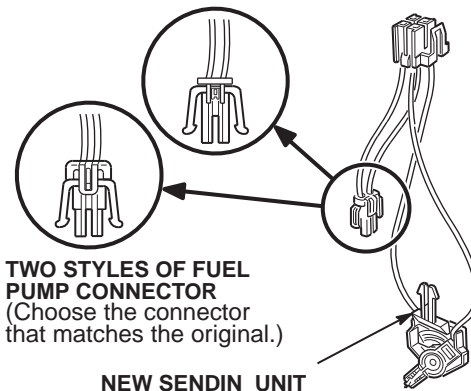

19. Install the new sending unit:

Plug this connector into the top plate, and install the new (red) locking clip.

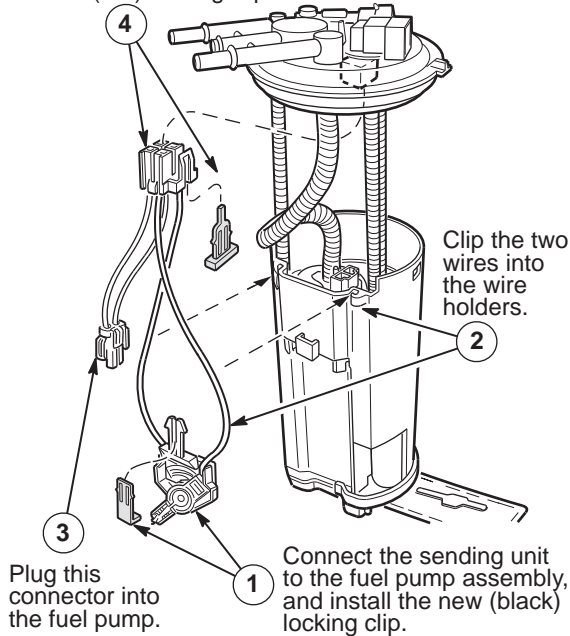

20. Reinstall the original float arm by pushing on its pivot point to snap it into place. After installation, make sure the arm moves freely under its own weight. If it does *not*, the pivot arm is bent, and the sending unit will *not* show the correct fuel level. To repair a bent pivot point, remove the arm, bend the pivot point back to its original 90-degree position, and reinstall the arm.

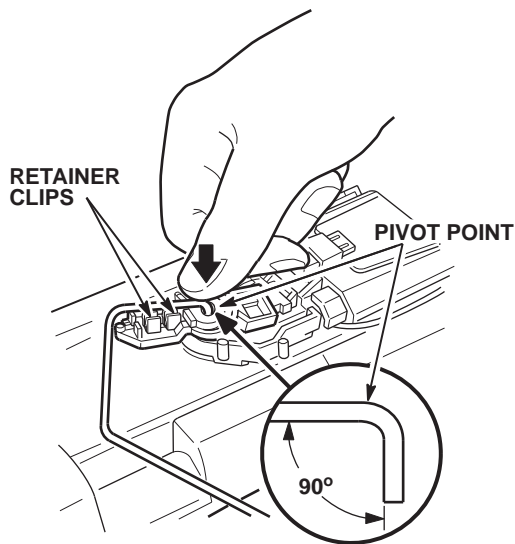

21. Move the float arm to its lowest position, then connect a DVOM to the sending unit, and measure the resistance. Resistance should be about 290 ohms. If the resistance is about 120 ohms, you have reinstalled the original sending unit.

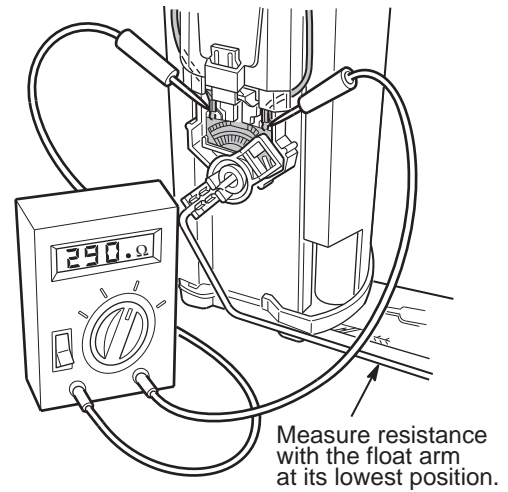

22. Discard the original sending unit and the unused unit from the kit.
23. Make sure the fuel pump opening on the tank is clean, then reinstall the pump assembly and its snap ring.
24. Reconnect the fuel feed hose and the fuel return hose to the fuel pump.
25. Raise the tank close to its installed level with the powertrain lift or jack, then plug in the fuel pump/sending unit harness and the fuel tank pressure sensor harness.
26. Raise the tank all the way, then reinstall its nuts and bolts. Torque the nuts and bolts to **68 N•m (50 lb-ft)**.
27. Reconnect the fuel feed hose and the fuel return hose to the fuel filter and the fuel line at the front of the tank. Attach the hoses to the support clip.
28. Reconnect the EVAP hose, the fuel filler vent hose, and the fuel filler hose to the fittings on the back of the tank. Make sure the hoses are not kinked or crushed, then lower the vehicle.
29. Refill the tank with the fuel you drained, and reinstall the fuel fill cap.
30. Reconnect the negative cable to the battery.
31. Enter your customer's radio station presets and mode settings. Reset the clock.
32. The PCM needs to be updated. Contact Par Tech Inc. at 248-276-0123 to have the PCM updated.
33. Clear any remaining DTCs with an appropriate scan tool.
34. Recheck the broadcast code with the generic scan tool. The code must *not* match any of the codes listed in step 1.