

SB-10055306-6071

Seat Harness Routing (Swivel)
 VAH, VHD, VN

FSB 375-011, Seat Harness Routing (Swivel)

(March 2014)

Vehicles equipped with a driver side swivel seat and I shift transmission built prior to November 06, 2013, may experience the seat harness dropping or pulling away from the clipping points. This could lead to the harness rubbing or wires being pulled out of connectors during operation.

To correct the situation a new routing has been implemented to prevent the above failures.

Required Parts

Quantity	Part Number	Description
1	20885496	Double Cable Tie
2	21096682	Cable Tie with Horizontal Edge Clip
1	25375492	Cable Tie with Vertical Edge Clip

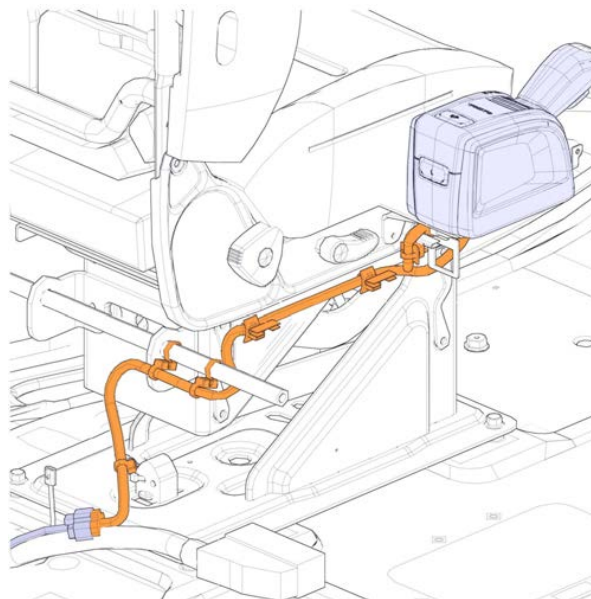

W3088667

Service personnel: Please circulate, read and initial

Service Manager	Warranty Administrator	Workshop Foreman	Service Technicians					

You must read and understand the precautions and guidelines in Service Information, group 30, "General Safety Practices, Electrical and Electronics" before performing this procedure. If you are not properly trained and certified in this procedure, ask your supervisor for training before you perform it.

Repair

- 1 Secure the vehicle for service by parking it on a flat level surface, applying the parking brake, chocking the rear wheel, and placing the transmission in neutral.
- 2 Disconnect all cables from the negative (ground) battery terminals to prevent personal injury from electrical shock and prevent damage to electrical components.
- 3 Disconnect the wiring harness connector at the shifter.

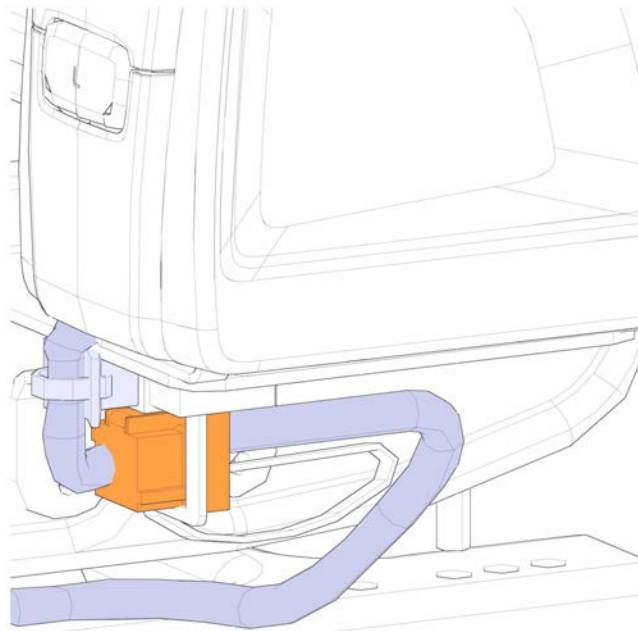

W3076414

- 4 Remove the cable ties from each clip point until the shifter harness is free from the seat. Remove shifter harness.

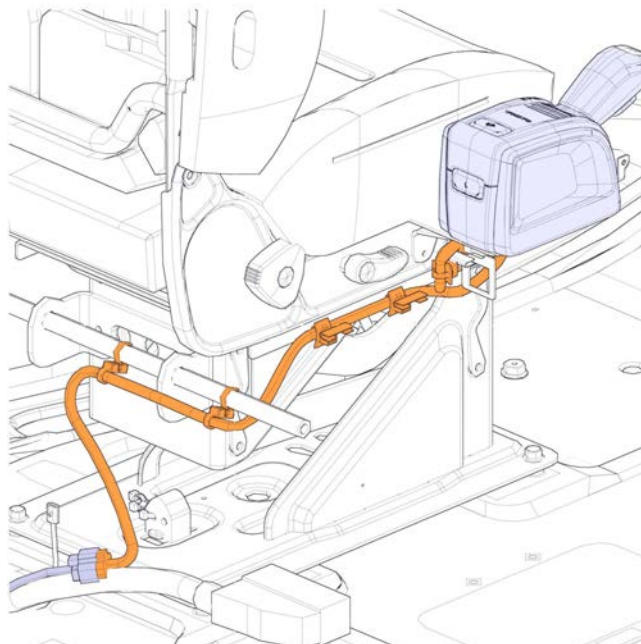

W3076516

Note: Look for chafed wires. Reuse harness if undamaged. If damaged repair as necessary.

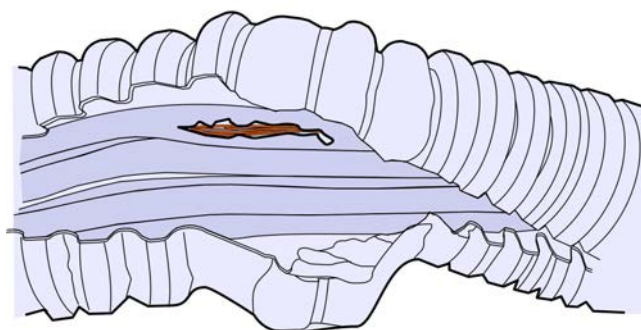

W3076421

- 5 Loosely install and cable tie along the new path for routing and clipping.

Note: Do not tighten cable ties fully at this time.

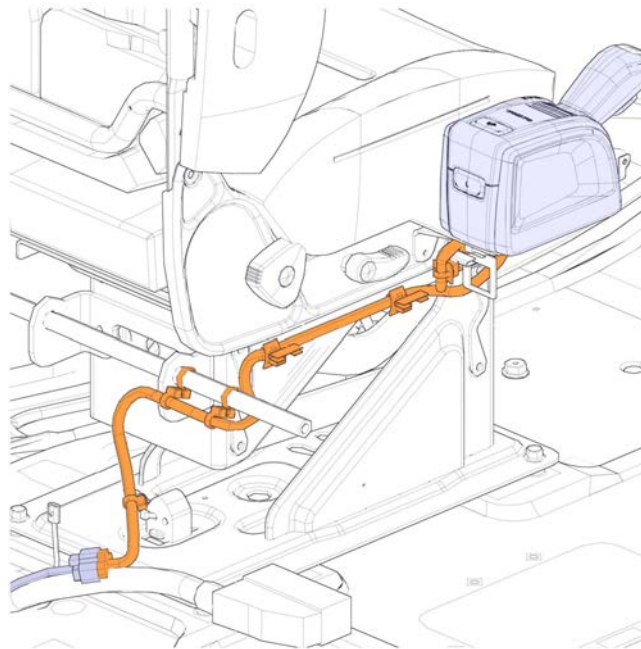

W3088667

Correct Routing
Cable Tie with Horizontal Edge Clip # 21096682, Qty 2

- 6 Connect the wiring harness connector at the shifter.

Note: The strain relief loop going to shifter will have increased in length with new routing and clipping method, to ensure no strain on wiring harness or shifter connector with seat in swivel position.

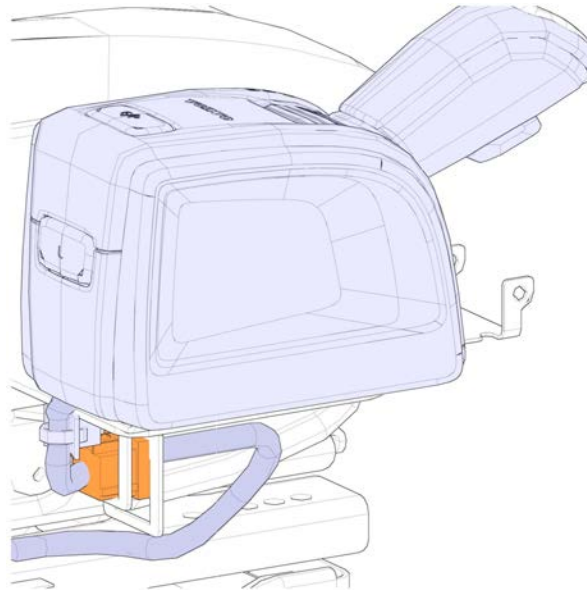

W3076416

- 7 Secure the harness along the new path by cinching the cable ties until the corrugated loom is lightly snug.

Note: Do not over tighten the cable ties, otherwise the harness and loom will become damaged.

- 8 Install all the previously removed cables to the negative (ground) battery terminals.

Reimbursement

This repair may be eligible for reimbursement if a product failure was experienced within time and mileage limits of the applicable Warranty coverage. Reimbursement is obtained via the normal claim handling process.	
Claim Type (used only when uploading from the Dealer Bus. Sys.)	W
Labor Code	
Primary Labor Code	37511-2-00 0.3 hrs.
Causal Part	20962710

Volvo Trucks North America engages in a comprehensive program of testing and evaluating to provide the best possible product. Volvo Trucks North America however, is not committed to, or liable for updating existing vehicles.