

**WE04 - Replacing Return Line for Clutch Master Cylinder (Workshop Campaign)**

Vehicle Type: **911 Carrera (991)/911 Carrera S (991)**  
**911 Carrera 4 (991)/911 Carrera 4S (991)**

Model Year: **2013**

Equipment: 7-speed manual transmission (I-no. 487)

Concerns: **Clutch master cylinder return line**

Information: This is to inform you of a voluntary Workshop Campaign on the above-mentioned vehicles. **A return line for the clutch master cylinder that does not meet the required specifications was installed in the affected vehicles.**

As a result, there is a possibility that brake fluid may leak out at the return line connection to the reservoir and the message "Warning Brake fluid level" may be activated in the multi-function display.

Action Required: Replace return line on the clutch master cylinder.

Affected Vehicles: The VIN(s) can be checked by using PIWIS Vehicle Information link to verify if the campaign affects the vehicle. This campaign is scope specific to the VIN! Failure to verify in PIWIS may result in an improper repair. This campaign affects 887 vehicles in North America.

Work Procedure: See Attachment "A".

Claim Submission: See Attachment "B".

Parts Info: **NOTES:**  
**1. Only Part number 000.043.110.41 for left-hand drive vehicles will be automatically allocated** for up to 50% of the vehicles that are serviced at your dealership. Once you are out of stock and need additional parts, please submit a PTEC/PAV.  
**2.** Part number 000.043.110.42 for right-hand drive vehicles, if required, must be ordered via a PTEC/PAV.  
**3.** Part number 000.043.203.66, brake fluid, should be ordered through normal channels.

Part No.	Designation	Qty. (ea.)	Version	
			LHD I-no. 098	RHD I-no. 099
000.043.110.41	⇒ Intake pipe for clutch master cylinder	1	■	
000.043.110.42	⇒ Intake pipe for clutch master cylinder	1		■
000.043.203.66	⇒ Brake fluid	1	■	■

- Special Tools:
- **9781 - Bleeding tool**
  - **VAS 6860 - Brake filling and bleeding equipment**

**CAUTION**

Increased risk of accidents when working with brake fluid.

- Possible danger of damage or injury.
  - Brake fluid on electrical contacts (even thinned brake fluid) leads to corrosion and may cause faults in the system.
- ⇒ Wear protective goggles and gloves.
- ⇒ IMMEDIATELY remove any escaped brake fluid. CAREFULLY rinse again with water and dry if necessary. Look out for fuse carrier!

Attachment "A": **Work Procedure**

**1 Preliminary work.**

- 1.1 Unclip cover ⇒ *Cover in service position -1-* at the left and right, lift it up and engage the yellow support in the front lid ⇒ *Cover in service position -arrows-*.
- 1.2 Place sufficient cleaning cloths in the area around the reservoir and clutch master cylinder.

**2 Replace return line for clutch master cylinder.**

- 2.1 Before pulling off the return line at the reservoir, position a suitable collection container underneath the adapter.
- 2.2 Pull off the return line ⇒ *Removing return line -1-* at the reservoir ⇒ *Removing return line -2-* (⇒ *Removing return line -arrow A-*) and collect the brake fluid in the container until no more brake fluid emerges.

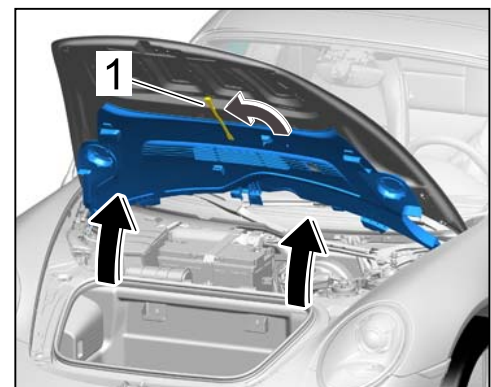

*Cover in service position*

If the sealing ring fitted in the return line is on the adapter after you pull off the return line, carefully remove the sealing ring using needle-nose pliers and dispose of it.

- 2.3 Pull off return line ⇒ *Removing return line -1-* on the clutch master cylinder ⇒ *Removing return line -3-* (⇒ *Removing return line -arrow B-*) and remove it in an upward direction.

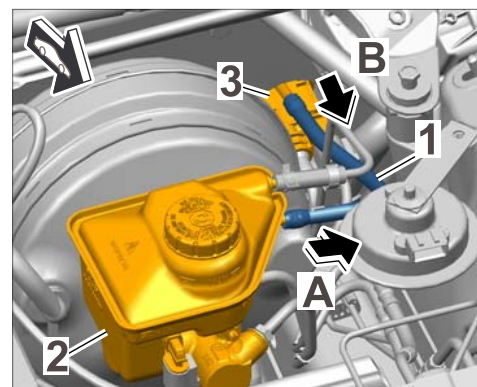

Removing return line

- 2.4 Push new return line ⇒ *Installing return line -1-* as far as it will go onto the clutch master cylinder ⇒ *Installing return line -3-* (⇒ *Installing return line -arrow A-*) until it engages securely.

- 2.5 Push return line ⇒ *Installing return line -1-* as far as it will go onto the reservoir ⇒ *Installing return line -2-* (⇒ *Installing return line -arrow B-*) until it engages securely.

- 2.6 Remove the cleaning cloths you positioned earlier and dispose of them in accordance with legal requirements.

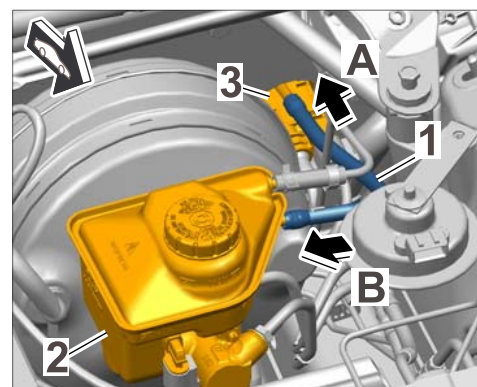

Installing return line

3 **Subsequent work.**

- 3.1 Bleed the clutch ⇒ *Workshop Manual '300107 Bleeding the clutch system - section on "Bleeding"*.
- 3.2 Disengage the yellow support at the front lid and clip in cover at the left and right ⇒ *Clipping in cover -arrows-*.

- 4 Enter the workshop campaign in the Warranty and Maintenance booklet.

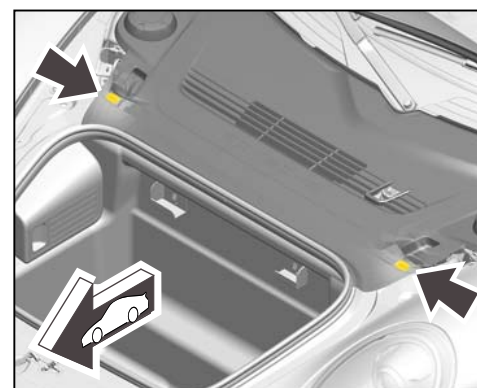

Clipping in cover

Attachment "B" **Claim Submission** - Workshop Campaign WE04

Warranty claims should be submitted via WWS/PQIS.

Open campaigns may be checked by using either the PIWIS Vehicle Information system or through PQIS Job Creation.

Labor, parts, and sublet will be automatically inserted when Technician is selected in WWS/PQIS. If necessary, the required part numbers will need to be manually entered into warranty system by the dealer administrator.

Scope 1:

**Valid for:**

- **911 Carrera Coupé (991) with 7-speed manual transmission (I-no. 487) and left-hand drive (LHD) version (I-no. 098)**

**Working time:**

Replacing return line on clutch master cylinder

Labor time: **66 TU**

Includes: Moving cover into service position  
Removing and installing cover for rear underbody  
Bleeding the clutch system

**Parts required:**

000.043.110.41	Intake pipe for clutch master cylinder	1 ea.
000.043.203.66	Brake fluid	1 ea. (i.e. 1 liter of brake fluid)

⇒ Damage code WE04 066 000 2

Scope 2:

**Valid for:**

- **911 Carrera Coupé (991) with 7-speed manual transmission (I-no. 487) and right-hand drive (RHD) version (I-no. 099)**

**Working time:**

Replacing return line on clutch master cylinder

Labor time: **66 TU**

Includes: Moving cover into service position  
Removing and installing cover for rear underbody  
Bleeding the clutch system

**Parts required:**

000.043.110.42	Intake pipe for clutch master cylinder	1 ea.
000.043.203.66	Brake fluid	1 ea. (i.e. 1 liter of brake fluid)

⇒ Damage code WE04 066 000 2

Scope 3:

**Valid for:**

- **911 Carrera Cabriolet (991) with 7-speed manual transmission (I-no. 487) and left-hand drive (LHD) version (I-no. 098)**

**Working time:**

Replacing return line on clutch master cylinder

Labor time: **59 TU**

Includes: Moving cover into service position  
 Removing and installing cover for rear underbody  
 Bleeding the clutch system

**Parts required:**

000.043.110.41	Intake pipe for clutch master cylinder	1 ea.
000.043.203.66	Brake fluid	1 ea. (i.e. 1 liter of brake fluid)

⇒ Damage code WE04 066 000 2

Scope 4:

**Valid for:**

- **911 Carrera Cabriolet (991) with 7-speed manual transmission (I-no. 487) and right-hand drive (RHD) version (I-no. 099)**

**Working time:**

Replacing return line on clutch master cylinder

Labor time: **59 TU**

Includes: Moving cover into service position  
 Removing and installing cover for rear underbody  
 Bleeding the clutch system

**Parts required:**

000.043.110.42	Intake pipe for clutch master cylinder	1 ea.
000.043.203.66	Brake fluid	1 ea. (i.e. 1 liter of brake fluid)

⇒ Damage code WE04 066 000 2

References: ⇒ *Workshop Manual '300107 Bleeding the clutch system - section on "Bleeding"*

**Important Notice:** Technical Bulletins issued by Porsche Cars North America, Inc. are intended only for use by professional automotive technicians who have attended Porsche service training courses. They are written to inform those technicians of conditions that may occur on some Porsche vehicles, or to provide information that could assist in the proper servicing of a vehicle. Porsche special tools may be necessary in order to perform certain operations identified in these bulletins. Use of tools and procedures other than those Porsche recommends in these bulletins may be detrimental to the safe operation of your vehicle, and may endanger the people working on it. Properly trained Porsche technicians have the equipment, tools, safety instructions, and know-how to do the job properly and safely. If a particular condition is described, do not assume that the bulletin applies to your vehicle, or that your vehicle will have that condition. See your authorized Porsche Dealer for the latest information about whether a particular technical bulletin applies to your vehicle. Part numbers listed in these bulletins are for reference only. Always check with your authorized Porsche dealer to verify the current and correct part numbers. The work procedures updated electronically in the Porsche PIWIS diagnostic and testing device take precedence and, in the event of a discrepancy, the work procedures in the PIWIS Tester are the ones that must be followed.

© Porsche Cars North America, Inc.

---

Dealership	Service Manager	_____	Shop Foreman	_____	Service Technician	_____	_____	_____	_____
Distribution									
Routing	Asst. Manager	_____	Warranty Admin.	_____	Service Technician	_____	_____	_____	_____

---

Dr. Ing. h.c. F. Porsche AG is the owner of numerous trademarks, both registered and unregistered, including without limitation the Porsche Crest®, Porsche®, Boxster®, Carrera®, Cayenne®, Cayman®, Macan®, Panamera®, Speedster®, Spyder®, 918 Spyder®, Tiptronic®, VarioCam®, PCM®, PDK®, 911®, RS®, 4S®, FOUR, UNCOMPROMISED®, and the model numbers and the distinctive shapes of the Porsche automobiles such as, the federally registered 911 and Boxster automobiles. The third party trademarks contained herein are the properties of their respective owners. Porsche Cars North America, Inc. believes the specifications to be correct at the time of printing. Specifications, performance standards, standard equipment, options, and other elements shown are subject to change without notice. Some options may be unavailable when a car is built. Some vehicles may be shown with non-U.S. equipment. The information contained herein is for internal authorized Porsche dealer use only and cannot be copied or distributed. Porsche recommends seat belt usage and observance of traffic laws at all times.

Printed in the USA