



Mack Trucks, Inc.
Greensboro, NC USA

Service Program Trucks

This Service Program replaces PV729–PI0849 (USA64813), “Front Axle Wedge, Installation” dated 5.2014.

Date	Group	No.	Release	Page
5.2014	721	002	01	1(7)

SB-10056002-9881

Front Axle Wedge, Installation
CHU

PI0849, Front Axle Wedge, Installation

(May 2014)

The front axle u-bolt wedges were installed incorrectly on some MACK CHU trucks built between 11/11/2013 and 02/24/2014. The incorrect installation of the wedge caused the u-bolts to bend on the front axle. Proper orientation of the wedge, replacement of the u-bolts and nuts will ensure the front axle u-bolts will not bend. See the table below for the new front axle wedge installation parts, and then follow the installation procedures outlined in this document.

Note: This bulletin does not apply to MACK Trucks Australia.

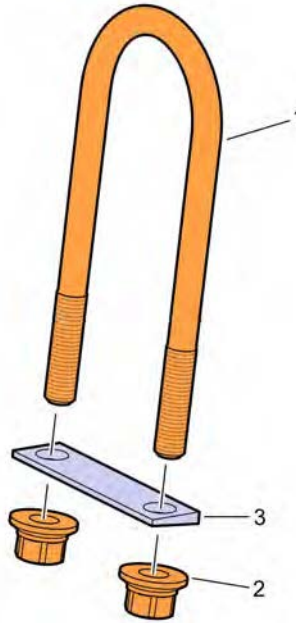

W7089864

Required Parts

Front Axle Wedge, Installation Parts			
Item	Qty	Part Number	Description
1	4	21180646	U-Bolt
2	8	21823706	Nut
3	2	N/A	Wedge

Front Axle Wedge Installation Procedure

You must read and understand the precautions and guidelines in Service Information, group 70, "General Safety Practices, Frame, Springs, Shocks and Wheels" before performing this procedure. If you are not properly trained and certified in this procedure, ask your supervisor for training before you perform it.

DANGER

Do not attempt to repair or service this vehicle without having sufficient training, the correct service literature and the proper tools. Failure to follow this could make the vehicle unsafe and lead to serious personal injury or death.

- 1 Park the vehicle on a level surface.
- 2 Apply the parking brake.
- 3 Place the transmission in neutral or park.
- 4 Install the wheel chocks.

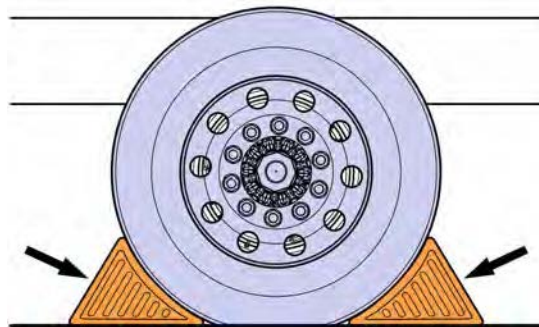

W7086748

- 5 Disconnect the cable from the battery's negative terminal.

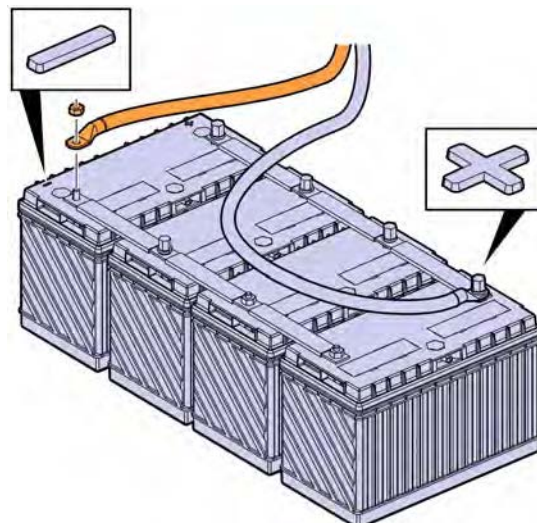

W3086747

- 6 Remove the u-bolt (1), wedge (2) and nuts (3) from the front axle.

Note: Left side shown.

Note: Remove the u-bolts one at a time as shown in the figure below.

Note: Do not discard the existing wedge. Clean the wedge of any debris and store for reuse.

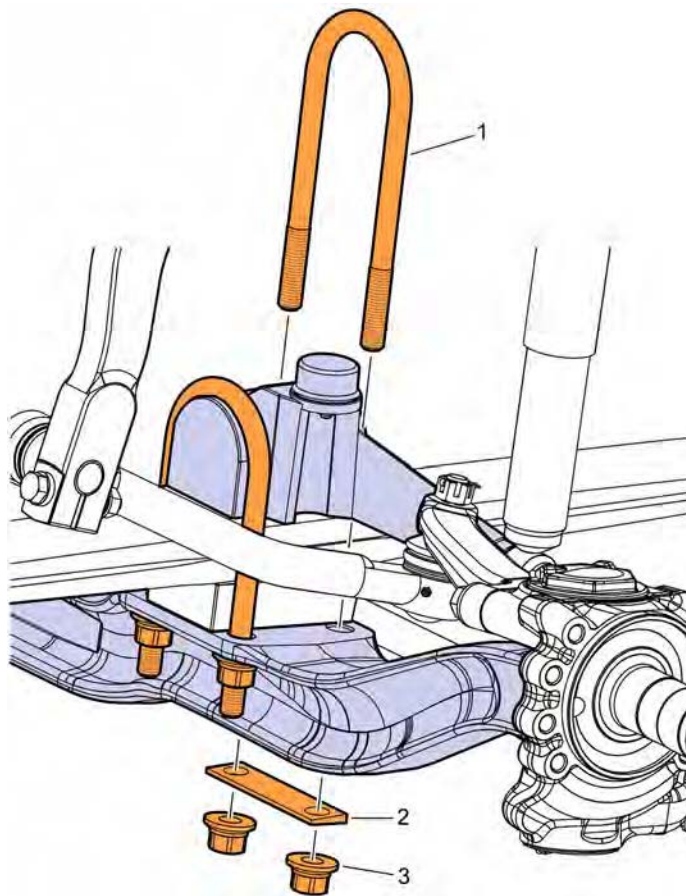

W7089865

7 Position the u-bolt, wedge and nuts on the front axle as shown.

Note: Use the existing wedge.

Note: Ensure the wedge is installed with the thick side facing rearward.

Note: Ensure the front axle locating features are utilized.

Note: Do not tighten the fasteners at this time. See the torque sequence chart after installation of both U-bolts.

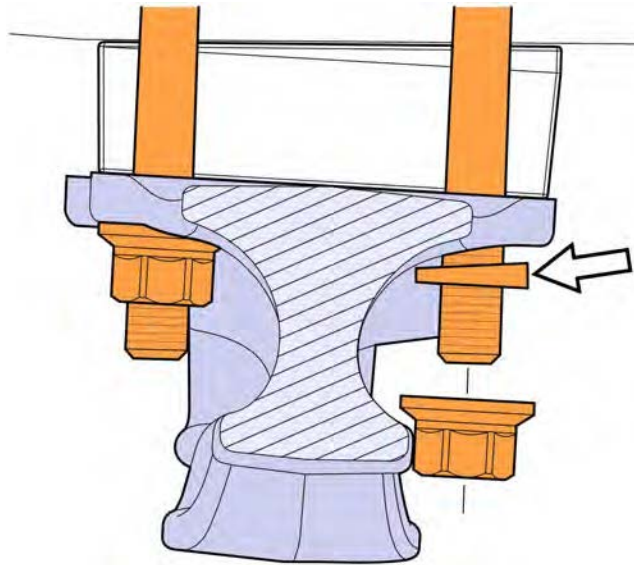

W7089867

8 Tighten the fasteners to specification as shown in the u-bolt torque sequence table below.

W7089868

U-bolt Torque Sequence		
Step	Tighten	Torque Specification
1	All four nuts in the cross pattern shown	40 Nm (29.5 ft-lb)
2	All four nuts in the cross pattern shown	135 Nm (99.6 ft-lb)
3	All four nuts in the cross pattern shown	250 Nm (184 ft-lb)
4	All four nuts in the cross pattern shown	350 Nm (258.1 ft-lb)
5	All four nuts in the cross pattern shown	550 Nm (405.7 ft-lb)

9 Repeat Steps 1–8 for the right side front axle wedge replacement.

10 Connect the battery cable to the negative (ground) terminal.

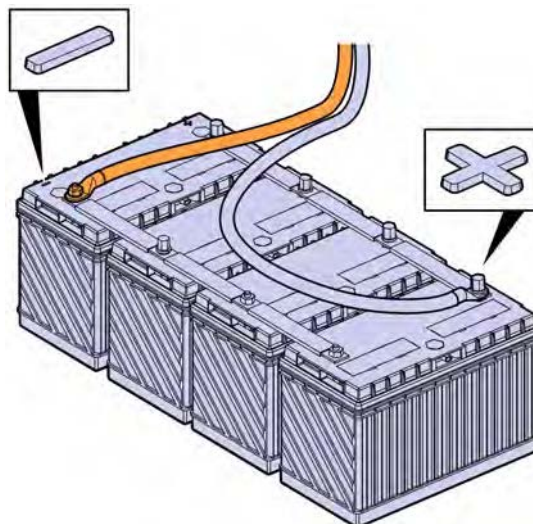

W3086758

11 Remove the wheel chocks.

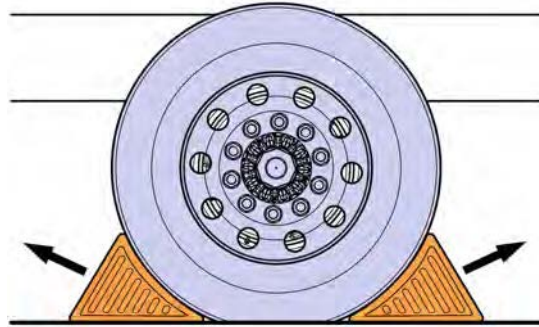

W7086759

Note: To signify that the campaign has been completed, using a permanent-type marker (such as a Sharpie®) to write the campaign number (PI0849) and completion date in the spaces provided on the Campaign Completion label located inside the cab as shown in the illustration below. If a label is not already affixed inside the cab, apply a label (part No. TS897) and supply the information as required. Campaign Completion labels are available in packs of 50 and can be ordered by faxing a completed BR313 to Pacesetters Business Services at 610-264-9465.

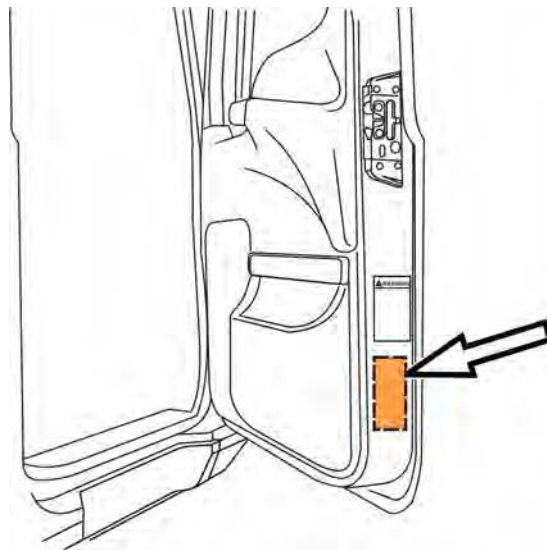

W8034103

Reimbursement

This repair is covered by an authorized Service Program. Reimbursement is obtained through the normal claim handling process.	UCHPR reimbursement	eWarranty Reimbursement
Claim Type (used only when uploading from the Dealer Bus. Sys.)	B	B
Recall Status		
Vehicle inspected, repair not required	1- Inspected OK	1- Inspected OK
Vehicle repaired per instruction	2- Modified per instruction	2- Modified per instruction
Labor Code		
Primary Labor Code	7211-02-09-02 1.5 hrs	1311F-ZQ-96 1.5 hrs.
Time to take charge and determine campaign status	1700-16-01-01 0.3 hrs	101AA-0A-00 0.3 hrs
Causal Part	8084707	8084707
SCC Code	S6571	N/A
Authorization Number	N/A	PI0849
Expiration Date	25-APR-2015	25-APR-2015

Note: Take Charge Time is not included in the Labor Code for this operation. Take charge may be eligible but can only be used once per repair visit. If vehicle is having other warranty repairs performed, take charge should be charged to the warranty repair, otherwise take charge can be charged to this service program.