

January 28, 2015

**SB-10057476-2891**

00280-01363 Version 2

## MIL Comes On with DTC P0087

Supersedes 14-039, dated October 11, 2014, to revise the information highlighted in **yellow**.

### AFFECTED VEHICLES

Year	Model	Trim	VIN Range
2013	Accord	L4	ALL
2014	Accord	4-Door - L4	1HGCR2...EA054295 to 1HGCR2...EA113613
2014	Accord	2-Door - L4	1HGCT1...EA004063 to 1HGCT1...EA006033

### REVISION SUMMARY

Under AFFECTED VEHICLES, 2013 models were added.

### SYMPTOM

The MIL is on with DTC P0087 (fuel rail pressure too low).

### POSSIBLE CAUSES

An internal component of the high pressure fuel pump causes low fuel pressure.

### CORRECTIVE ACTION

Replace the high pressure fuel pump.

### PARTS INFORMATION

Part Name	Part Number	Quantity
Fuel Joint Pipe Set	16012-5A2-315	1
Pump Assembly	16790-5A2-A01	1
Throttle Body Gasket	17107-R40-A01	1
Intake Manifold Gasket	17115-5A2-A01	4
Fuel Clip	17711-S0X-004	1

### WARRANTY CLAIM INFORMATION

The normal warranty applies.

Operation Number	Description	Flat Rate Time	Template ID	Failed Part Number
1211U6	Replace the high pressure fuel pump.	1.6 hours	14-039A	16790-5A2-A01

Defect Code: 07701

Symptom Code: 03203

Skill Level: Repair Technician

**CUSTOMER INFORMATION:** The information in this bulletin is intended for use only by skilled technicians who have the proper tools, equipment, and training to correctly and safely maintain your vehicle. These procedures should not be attempted by "do-it-yourselfers," and you should not assume this bulletin applies to your vehicle, or that your vehicle has the condition described. To determine whether this information applies, contact an authorized Honda automobile dealer.

## INSPECTION

Check the HDS On-Board Snapshot.

- If the **FUEL LEVEL** value is more than 3.5% go to REPAIR PROCEDURE.
- If the **FUEL LEVEL** value is less than or equal to 3.5%, this bulletin does not apply; continue with normal troubleshooting.

Signal	Value	Units
PNP SWITCH	P-N	
BRAKE SWITCH	OFF	
A/C SWITCH	ON	
A/C PRESSURE SENSOR	164.3	psi
A/C CLUTCH	ON	
VTEC PRES SW	ON	
VTEC SOLENOID VALVE	OFF	
F INJECTOR	7.42	ms
SPARK ADVANCE	3	"
CMP CTRL	0	"
CMP CTRL CMD	0	"
KNOCK RETARD	0.0	"
KNOCK CTRL	0.71	"
<b>FUEL LEVEL</b>	<b>92</b>	<b>%</b>
EVAP PC DUTY	25	%
EVAP CVS VALVE	OFF	
CRP PULSER F/B LEARN	COMPLETED	
START ECT	143.6	°F
START IAT	116.6	°F
MISFIRE	1	
MISFIRE DRIVING CYCLE	0	

## REPAIR PROCEDURE

NOTE: During the repair, follow the basic procedures listed below. For more detail about any of these procedures, see the electronic service manual.

- Fuel Pressure Relieving (L4).
- Camshaft Timing Inspection (L4).
- Intake Manifold Removal and installation (L4).

1. Remove the fuel bracket.

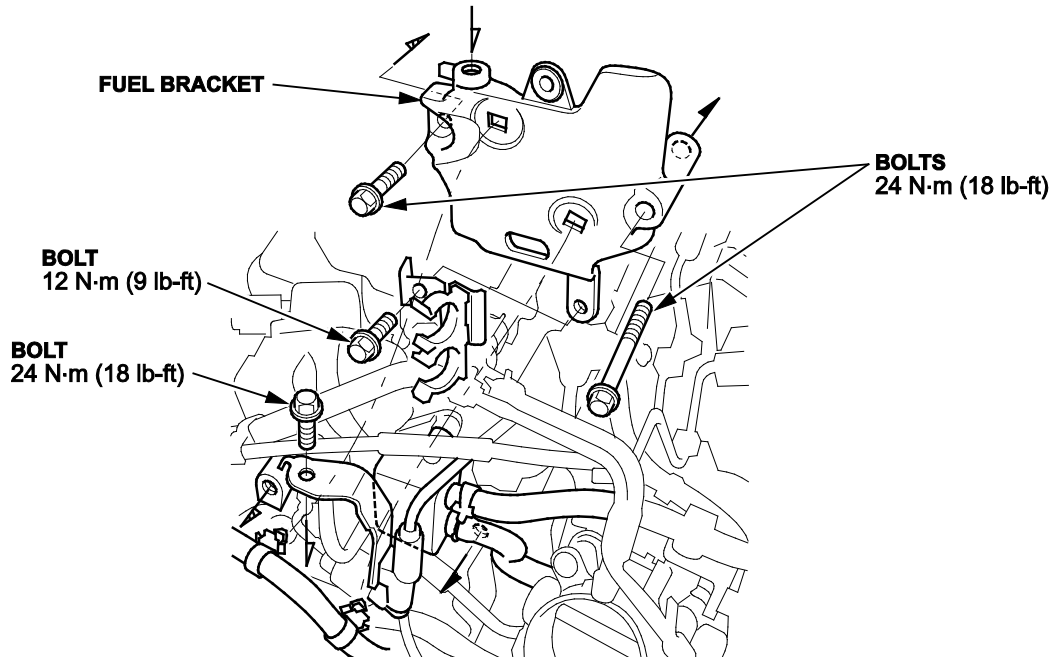

2. Remove the EVAP canister purge valve.

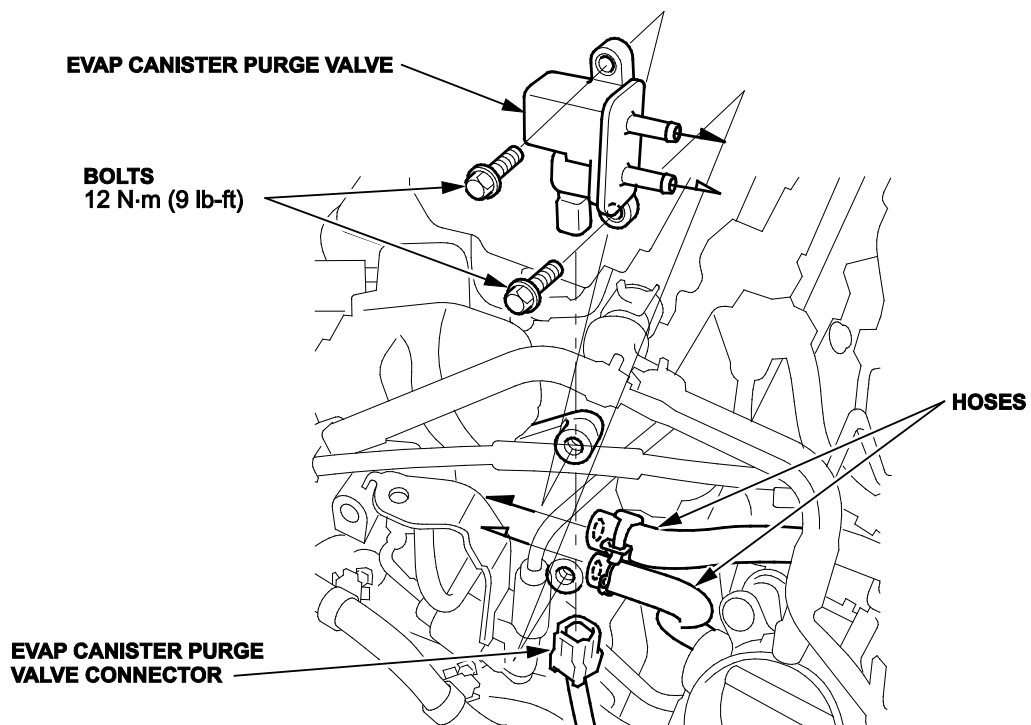

3. Remove the high pressure fuel pump cover.

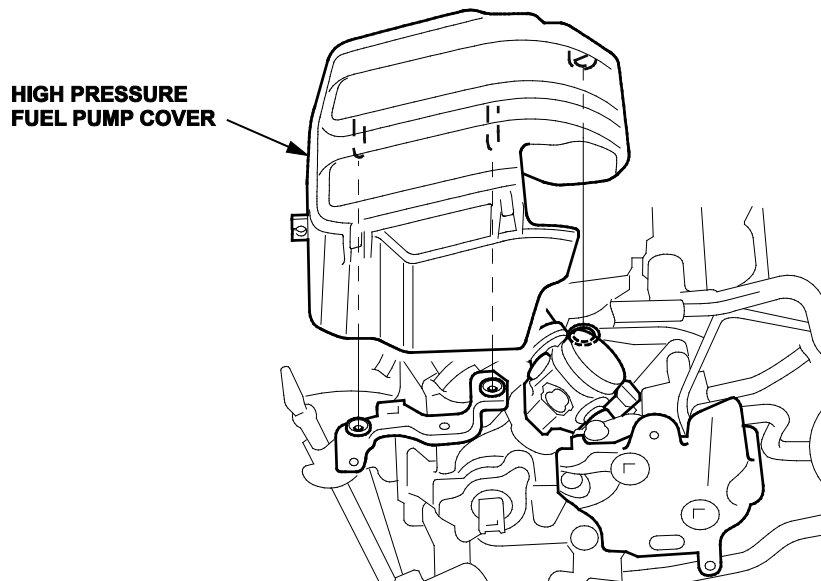

4. Remove the fuel joint pipe.

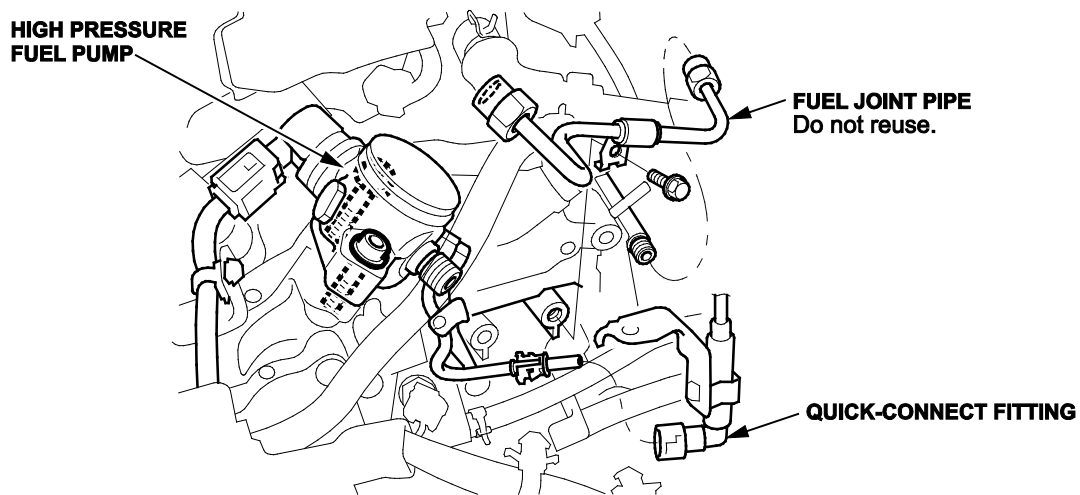

5. Remove the high pressure fuel pump.

**NOTE:** Set the No. 1 piston at top dead center (TDC), and then turn the crankshaft 105° counterclockwise before removing the high pressure fuel pump.

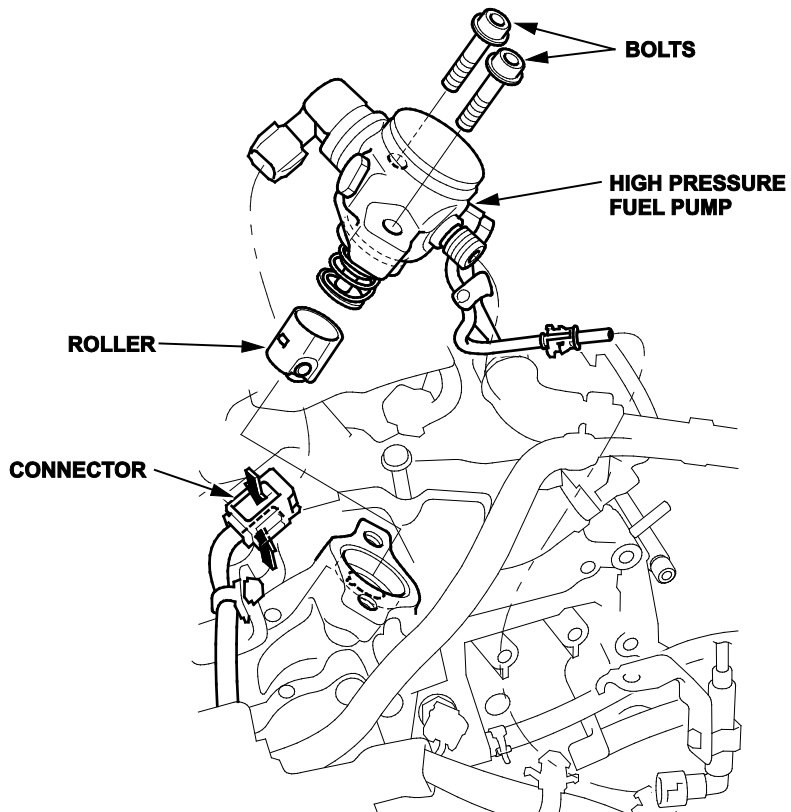

6. Turn the crankshaft and check the high pressure fuel pump cam for any pitting, scoring, or excessive wear. If needed, replace the fuel pump camshaft.

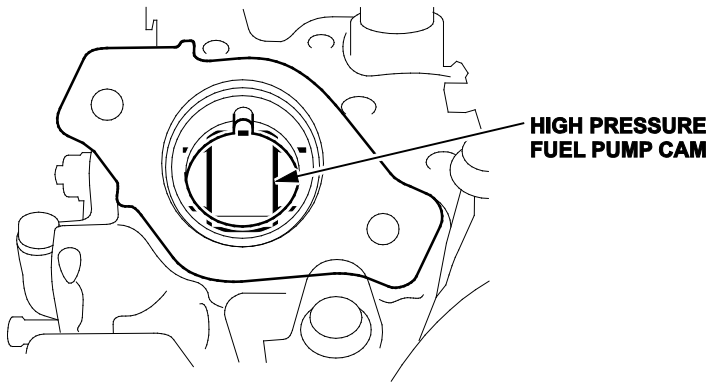

7. Set the No. 1 piston at top dead center (TDC), and then turn the crankshaft 105° counterclockwise. Check the position of the cam that drives the high pressure pump as shown. If the cam position is not correct, continue turning the camshaft until it is.

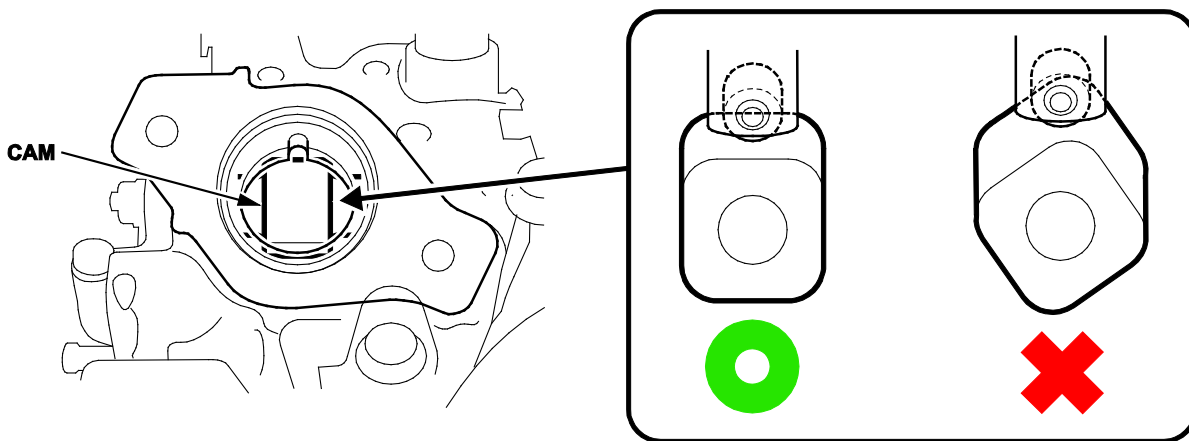

8. Lubricate the cam and roller with clean engine oil, and then install the high pressure fuel pump with the new fuel line clip. Loosely install the bolts.

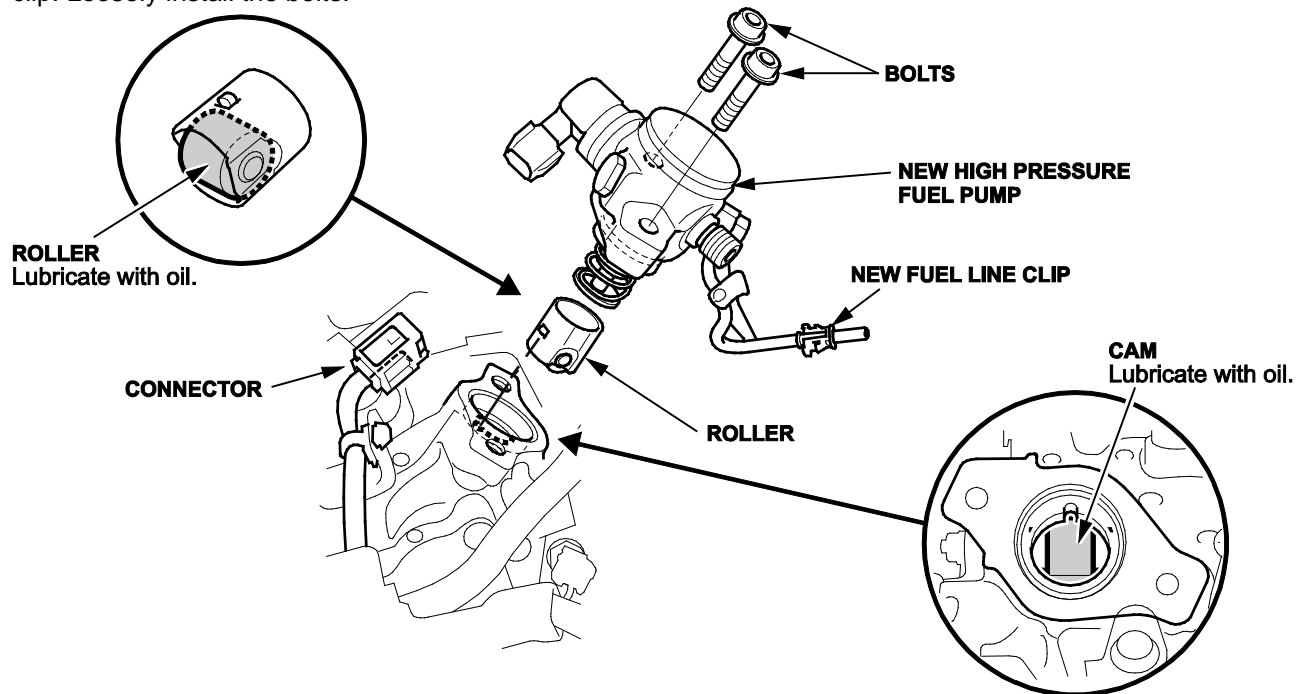

9. Apply the polyethylene glycol that is included with the fuel joint pipe to the areas shown, and then install the new fuel joint pipe.

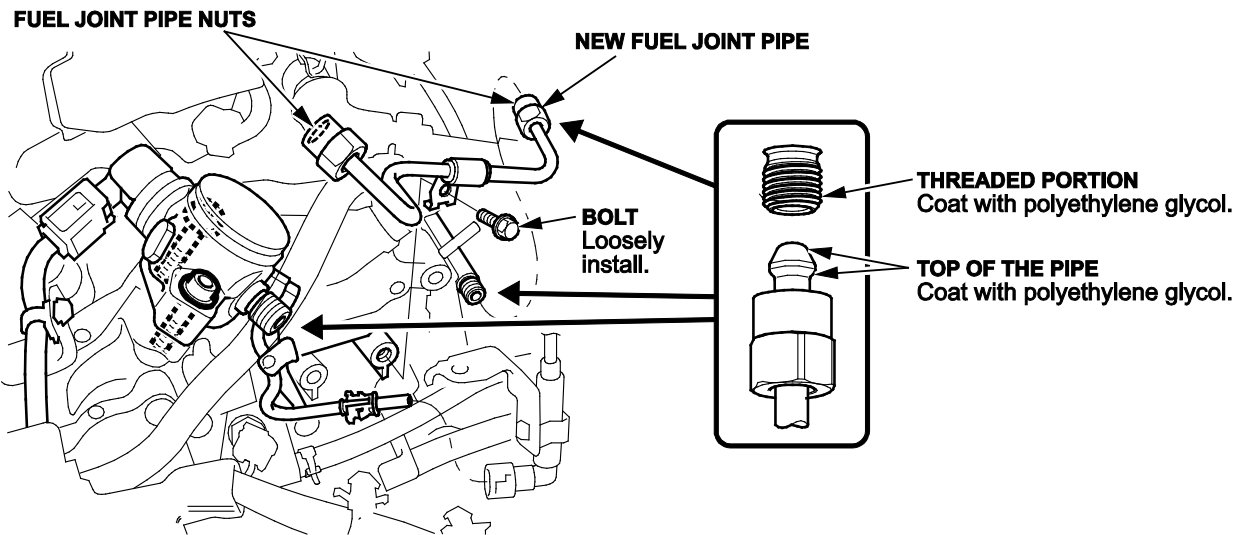

10. Torque the high pressure fuel pump mounting bolts and fuel joint pipe nuts to the specifications shown below.

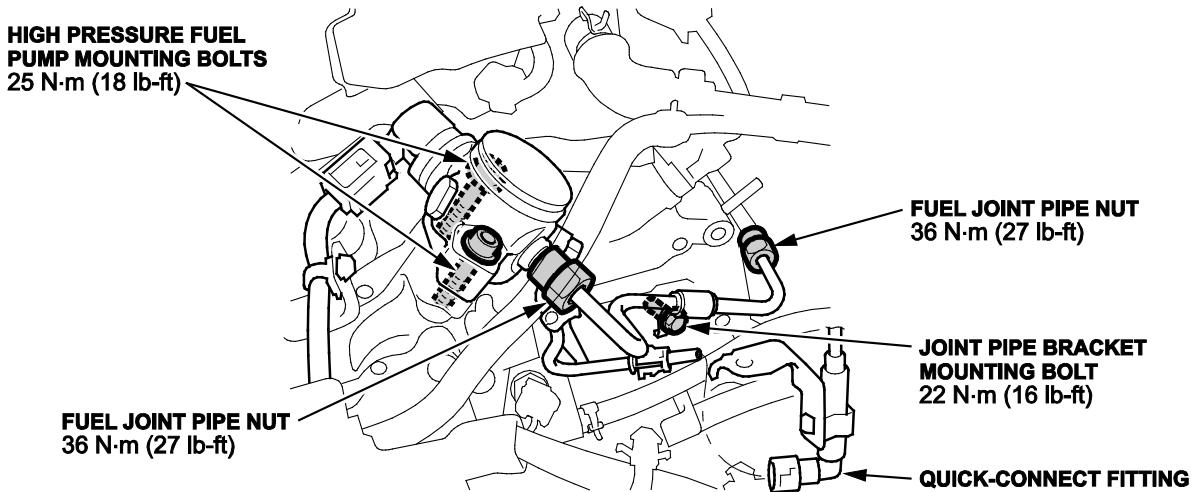

11. Reinstall the parts in reverse order, and then check for any fuel leaks.

END