



Technical Service Bulletin

| | | | |
|--|---|---|--|
| SUBJECT: | | | No: TSB-15-52A-001 |
| FRONT SEAT BELT ATTACHING INSTRUCTIONS - SERVICE MANUAL REVISION: REVISED | | | DATE: February, 2015 |
| | | | MODEL: See Below |
| CIRCULATE TO: | <input type="checkbox"/> GENERAL MANAGER | <input type="checkbox"/> PARTS MANAGER | <input checked="" type="checkbox"/> TECHNICIAN |
| <input checked="" type="checkbox"/> SERVICE ADVISOR | <input checked="" type="checkbox"/> SERVICE MANAGER | <input type="checkbox"/> WARRANTY PROCESSOR | <input type="checkbox"/> SALES MANAGER |

This bulletin supersedes TSB-11-52A-004, issued November, 2011 to add information for the outer seat belt on the front passenger's side seat. The Affected Vehicles list was also expanded to include additional models. Revisions are not indicated as this bulletin has been completely re-written.

PURPOSE

The lower front seat belt attaching method and the seat belt bolt tightening torque is incorrect in the 2011 – 2012 Outlander Sport service manual. The correct torque specification is 5.0 ± 1.0 Nm (44 ± 8 in/lb).

Also, all affected service manuals will be updated with information for the outer seat belt on the front passenger's side seat to clarify the front seat belt installation and removal procedure.

This bulletin provides the corrected information.

AFFECTED VEHICLES

2006 Eclipse
 2006 – 2015 Lancer
 2009 – 2015 Lancer Sportback
 2008 – 2015 Lancer Evolution
 2007 – 2013 Outlander
 2011 – 2015 Outlander Sport / RVR

AFFECTED SERVICE MANUALS

2006 Eclipse, Group 52A – Interior --> Front Seat Belt --> Removal and Installation
 2006 – 2010 Lancer, Group 52A – Interior --> Front Seat Belt --> Removal and Installation
 2009 – 2010 Lancer Sportback, Group 52A – Interior --> Seat Belt --> Front Seat Belt --> Removal and Installation
 2011 – 2015 Lancer / Lancer Sportback, Group 52A – Interior --> Seat Belt --> Front Seat Belt --> Removal and Installation
 2008 – 2015 Lancer Evolution, Group 52A – Interior --> Seat Belt --> Front Seat Belt --> Removal and Installation
 2007 – 2013 Outlander, Group 52A – Interior --> Seat Belt --> Front Seat Belt --> Removal and Installation
 2011 – 2015 Outlander Sport / RVR, Group 52A – Interior --> Front Seat Belt --> Removal and Installation

Please make the following changes to the 2006 Eclipse Service Manual, Group 52A – Interior ---> Front Seat Belt ---> Removal and Installation:

FRONT SEAT BELT

REMOVAL AND INSTALLATION

⚠ CAUTION

- When removing and installing the inner seat belt, be sure to carry out accuracy check occupant classification sensor after the seat has been installed in the vehicle. (Refer to GROUP 52B, On-Vehicle Service .)
- SRS: Before removing and installing the seat belts with pre-tensioner, refer to GROUP 52B, Seat Belt with Pre-tensioner .

Pre-removal and Post-installation Operation

- Turn the ignition key to the LOCK (OFF) position.
- Disconnect the negative battery terminal.
- ² Removal and Installation of Rear Seat Cushion Assembly and Rear Seatback Assembly.
- ² Removal and Installation of Scuff Plate, Rear Shelf Trim, Rear Side Trim, Quarter Trim Lower, Center pillar Trim Upper and Rear Pillar Trim.

Post-installation Operation

Adjustment Procedures of Special Function (refer to GROUP 52B, On-Vehicle Service .)

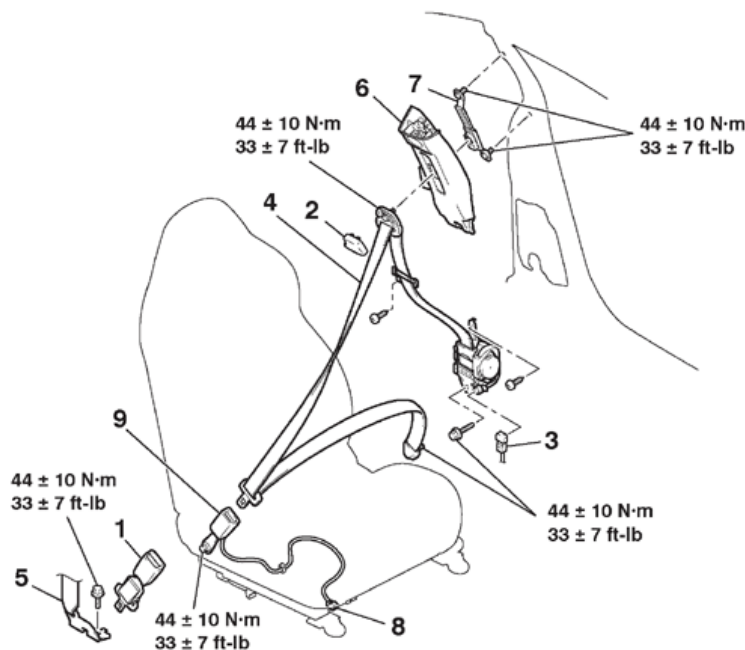

1. EXTENDER SEAT BELT ASSEMBLY*
OUTER SEAT BELT REMOVAL STEPS
2. SASH GUIDE COVER
 - CENTER PILLAR TRIM LOWER
3. PRE-TENSIONER CONNECTOR CONNECTION
4. OUTER SEAT BELT <DRIVER'S SIDE> (REFER TO GROUP 52B, SEAT BELTS WITH PRE-TENSIONER .)

5. OUTER SEAT BELT <DRIVER'S SIDE> (REFER TO GROUP 52B, SEAT BELTS WITH PRE-TENSIONER .)
6. CENTER PILLAR TRIM UPPER
7. ADJUSTABLE SEAT BELT ANCOR

<Correct>

PASSENGER'S

AC405666 AB

OUTER SEAT BELT REMOVAL STEPS (Continued) <Incorrect>

<DRIVER'S

Please make the following changes to the 2006 Lancer Service Manual, Group 52A – Interior --> Front Seat Belt --> Removal and Installation:

FRONT SEAT BELT

REMOVAL AND INSTALLATION

⚠ CAUTION

SRS: Before removing and installing the seat belts with pre-tensioner, refer to GROUP 52B – SRS Service Precautions and Seat Belt with Pre-tensioner .

Pre-removal and Post-installation Operation

- Turn the ignition key to the LOOK (OFF) position.
- Disconnect the negative battery terminal.

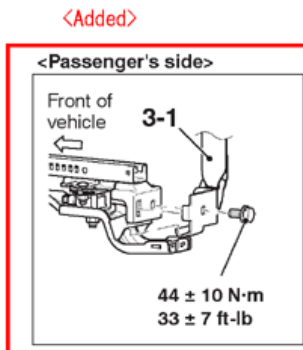
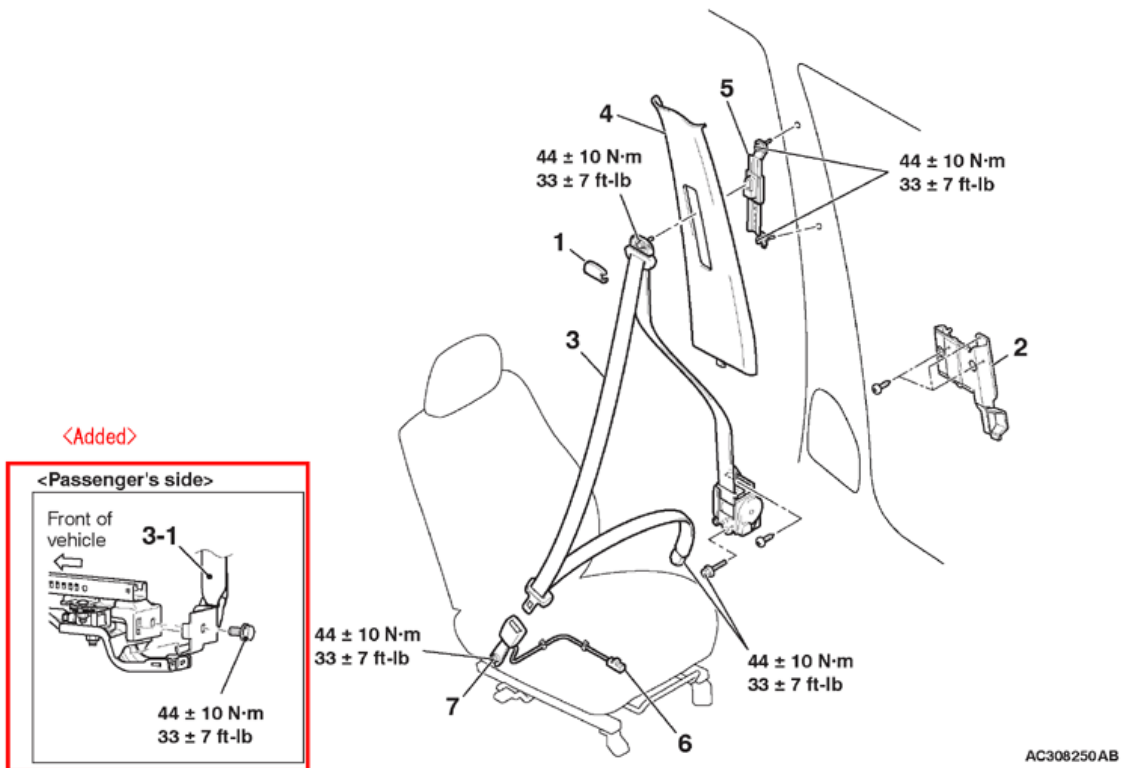

OUTER SEAT BELT REMOVAL STEPS

1. SASH COVER GUIDE
 - LOWER CENTER PILLAR TRIM
2. BRACKET
3. OUTER SEAT BELT <DRIVER'S SIDE> <Added> REFER TO GROUP 52B, SEAT BELT WITH PRE-TENSIONER .)

<Added> 3-1. OUTER SEAT BELT <PASSENGER'S SIDE> (REFER TO GROUP 52B, SEAT BELT WITH PRE-TENSIONER .)

OUTER SEAT BELT REMOVAL STEPS (Continued)

4. UPPER CENTER PILLAR TRIM
 5. ADJUSTABLE SEAT BELT ANCHOR
- #### INNER SEAT BELT REMOVAL STEPS
6. HARNESS CONNECTOR
 - SHIELD COVER
 7. INNER SEAT BELT

Please make the following changes to the 2008 – 2010 Lancer Service Manual, Group 52A – Interior
 --> Front Seat Belt --> Removal and Installation:

FRONT SEAT BELT

REMOVAL AND INSTALLATION

⚠ CAUTION

SRS: Before removing and installing the seat belts with pre-tensioner, refer to GROUP 52B – SRS Service Precautions and Seat Belt with Pre-tensioner .

Pre-removal and Post-installation Operation

- Turn the ignition key to the LOOK (OFF) position.
- Disconnect the negative battery terminal.

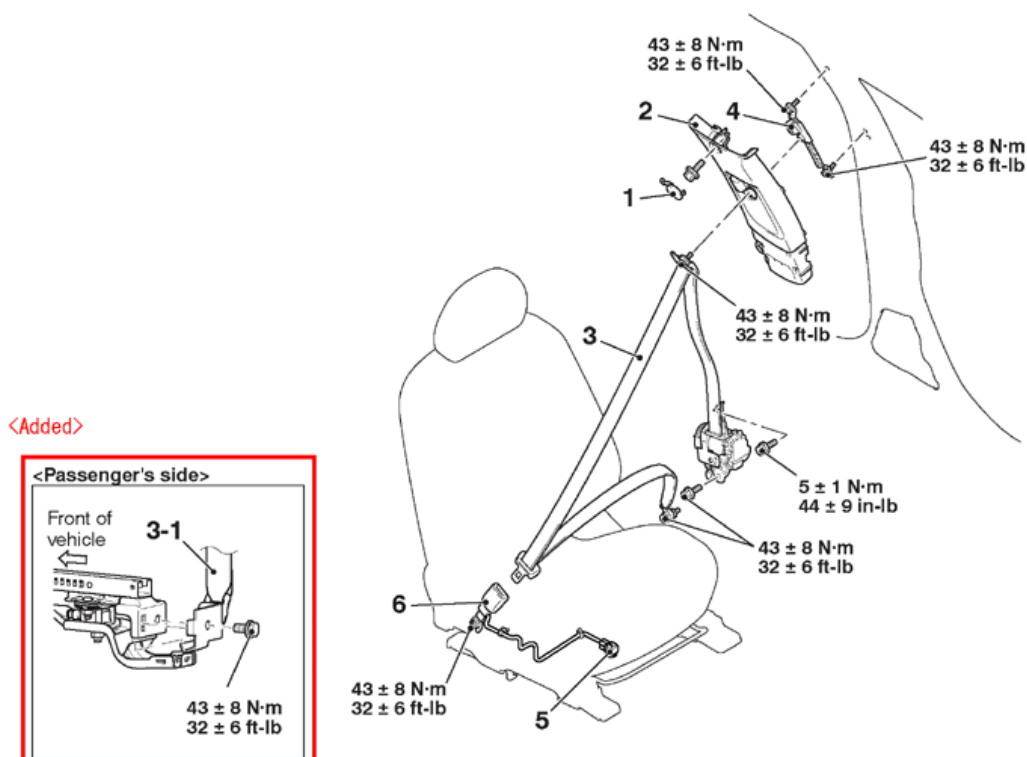

AC610305AB

<<A>>

Outer seat belt removal steps

1. Center pillar trim cap
 - Lower center pillar trim.
2. Upper center pillar trim. <Added>
3. Outer seat belt <Driver's side> (Refer to GROUP 52B, Seat Belt with Pre-tensioner).
- <Added> 3-1. Outer seat belt <Passenger's side> (Refer to GROUP 52B, Seat Belt with Pre-tensioner).
4. Adjustable seat belt anchor

Inner seat belt removal steps

5. Harness connector
 - Shield cover.
6. Inner seat belt

Required Special Tool:

- MB990784: Ornament Remover

Please make the following changes to the 2009 – 2010 Lancer Sportback Service Manual, Group 52A – Interior --> Seat Belt --> Front Seat Belt --> Removal and Installation:

SEAT BELT

FRONT SEAT BELT

REMOVAL AND INSTALLATION

⚠ CAUTION

SRS: Before removing and installing the seat belts with pre-tensioner, refer to GROUP 52B – SRS Service Precautions and Seat Belt with Pre-tensioner .

Pre-removal and Post-installation Operation

- Turn the ignition key to the LOOK (OFF) position.
- Disconnect the negative battery terminal.

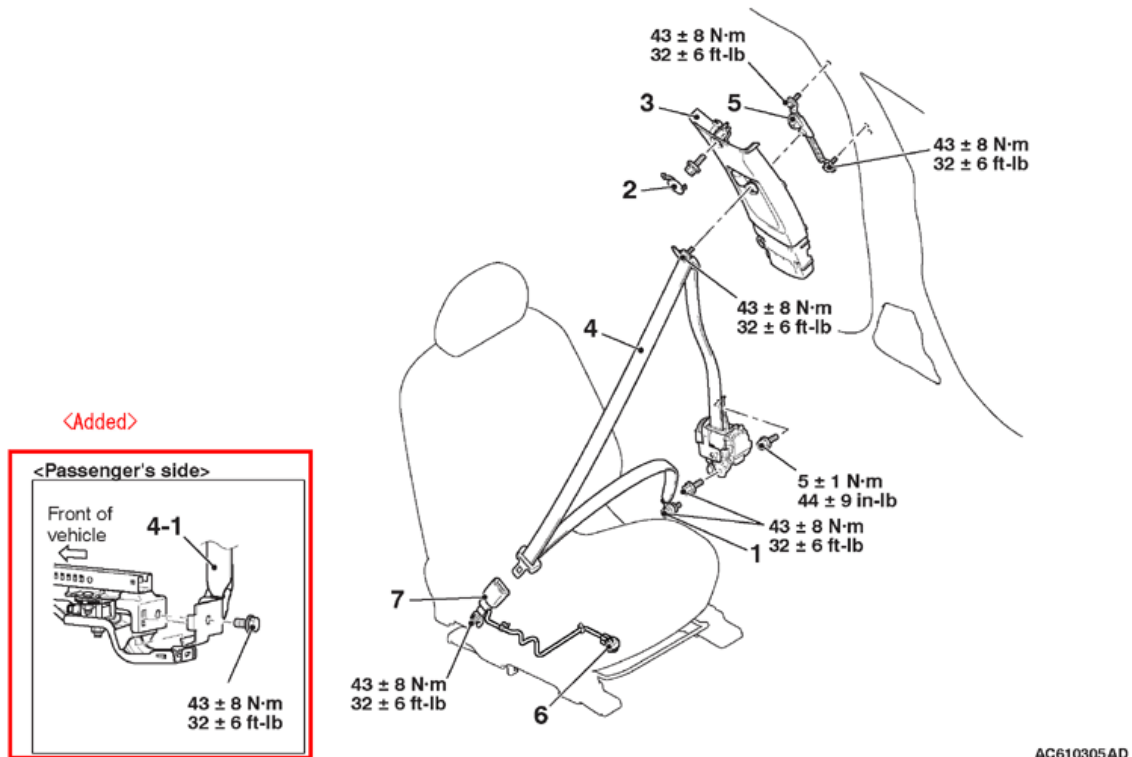

- <A>>
- Outer seat belt removal steps**
1. Outer seat belt lower anchor bolt
 2. Upper center pillar trim cap
 - Lower center pillar trim.
 3. Upper center pillar trim. <Added>
 4. Outer seat belt <Driver's side> (Refer to GROUP 52B, Seat Belt with Pre-tensioner).

- <Added>
- Outer seat belt removal steps**
- 4-1. Outer seat belt <Passenger's side> (Refer to GROUP 52B, Seat Belt with Pre-tensioner).
 5. Adjustable seat belt anchor
- Inner seat belt removal steps**
6. Harness connector
 - Side shield cover.
 7. Inner seat belt

Please make the following changes to the 2011 – 2015 Lancer / Lancer Sportback Service Manual, Group 52A – Interior --> Seat Belt --> Front Seat Belt --> Removal and Installation:

SEAT BELT

FRONT SEAT BELT

REMOVAL AND INSTALLATION

⚠ CAUTION

SRS: Before removing and installing the seat belts with pre-tensioner, refer to GROUP 52B – SRS Service Precautions and Seat Belt with Pre-tensioner .

Pre-removal and Post-installation Operation

- Turn the ignition key to the LOOK (OFF) position.
- Disconnect the negative battery terminal.

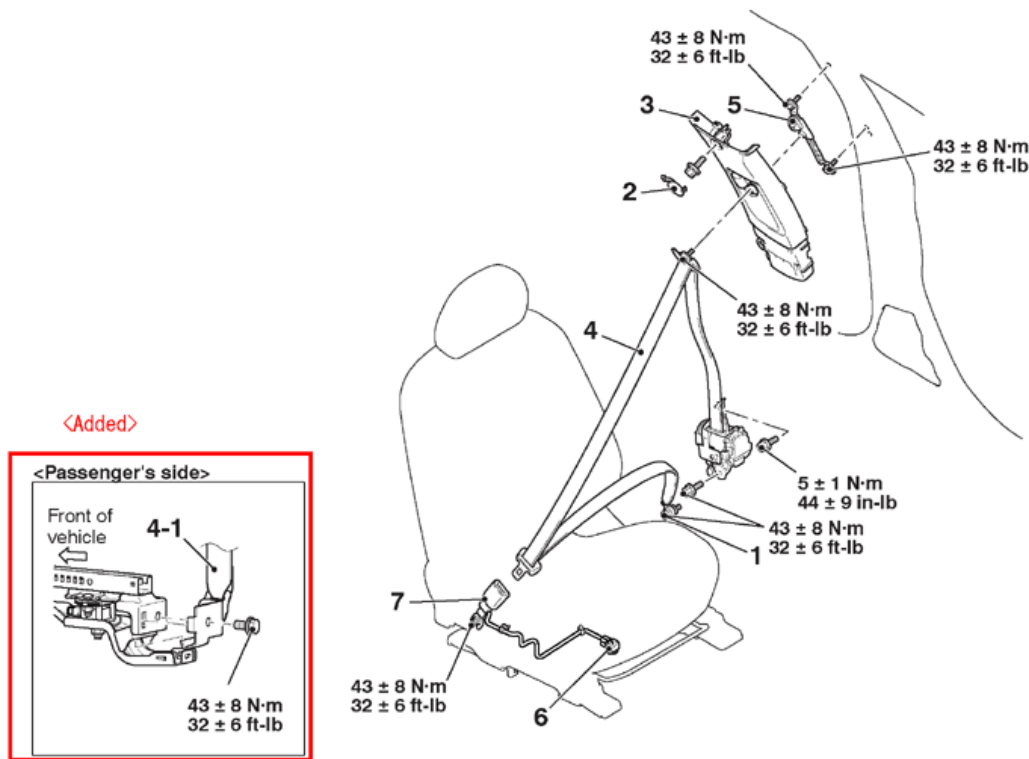

AC610305AD

<<A>>

Outer seat belt removal steps

1. Outer seat belt lower anchor bolt
2. Upper center pillar trim cap
 - Lower center pillar trim.
3. Upper center pillar trim. **<Added>**
4. Outer seat belt **<Driver's side>** (Refer to GROUP 52B, Seat Belt with Pre-tensioner).

<Added>

Outer seat belt removal steps

- 4-1. Outer seat belt **<Passenger's side>** (Refer to GROUP 52B, Seat Belt with Pre-tensioner).

Inner seat belt removal steps

6. Harness connector
 - Side shield cover.
7. Inner seat belt

Please make the following changes to the 2008 – 2015 Lancer Evolution Service Manual, Group 52A – Interior --> Seat Belt --> Front Seat Belt --> Removal and Installation:

SEAT BELT

FRONT SEAT BELT

REMOVAL AND INSTALLATION

⚠ CAUTION

SRS: Before removing and installing the seat belts with pre-tensioner, refer to GROUP 52B – SRS Service Precautions and Seat Belt with Pre-tensioner .

Pre-removal and Post-installation Operation

- Turn the ignition key to the LOOK (OFF) position.
- Disconnect the negative battery terminal.

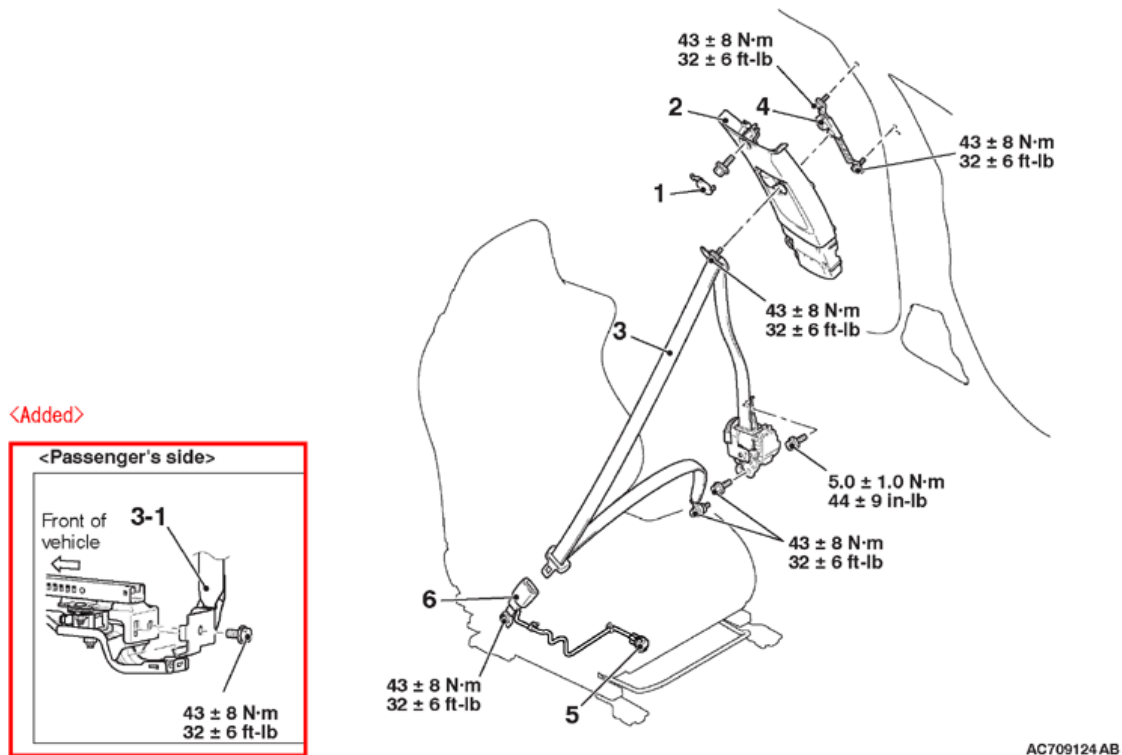

<Added>

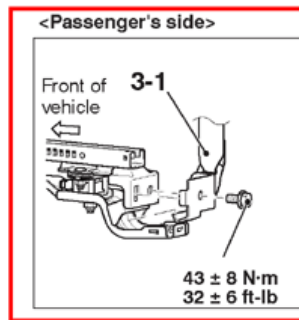

- <<A>>
- Outer seat belt removal steps**
1. Center pillar trim upper cap
 - Center pillar trim lower.
 2. Center pillar trim upper. <Added>
 3. Outer seat belt <Driver's side> (Refer to GROUP 52B, Seat Belt with Pre-tensioner).
- <Added>
- 3-1. Outer seat belt <Passenger's side> (Refer to GROUP 52B, Seat Belt with Pre-tensioner).
 4. Adjustable seat belt anchor

- Inner seat belt removal steps**
5. Harness connector
 - Shield cover.
 6. Inner seat belt

Required Special Tool:

- MB990784: Ornament Remover

Please make the following changes to the 2007 – 2013 Outlander Service Manual, Group 52A – Interior --> Seat Belt --> Front Seat Belt --> Removal and Installation:

SEAT BELT

FRONT SEAT BELT

REMOVAL AND INSTALLATION

CAUTION

For the removal of the seat belt with pre-tensioner, refer to GROUP 52B – Service Precautions (refer to) and Seat Belt with Pre-tensioner (refer to).

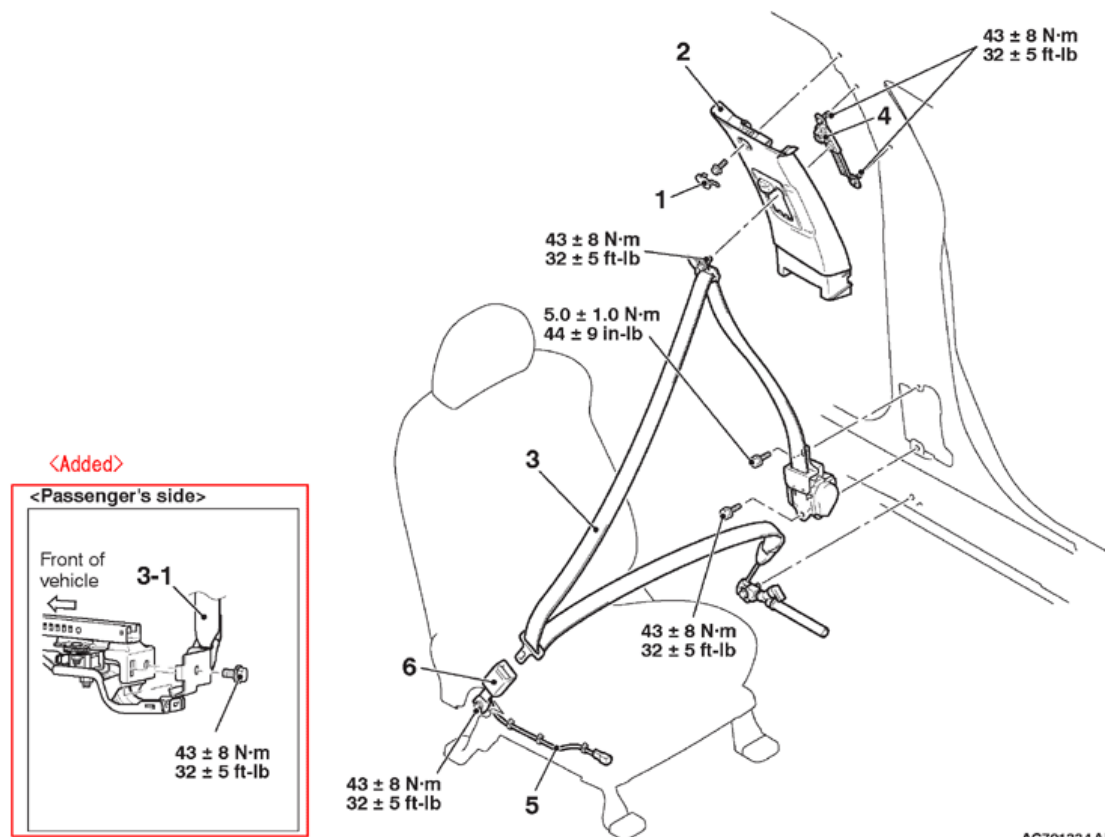

AC701334AD

Outer seat belt removal steps

- Front scuff plate, scuff plate rear, center pillar trim lower.
- 1. Center pillar trim upper cap
- 2. Center pillar trim upper.
- 3. Outer seat belt **<Driver's side>**

<Added>

Outer seat belt removal steps

- <Added> **3-1. Outer seat belt <Passenger's side>**
- 4. Adjuster seat belt anchor
- Inner seat belt removal steps**
- 5. Seat belt switch connector
- 6. Inner seat belt

Please make the following changes to the 2011 – 2012 Outlander Sport / RVR Service Manual, Group 52A – Interior --> Seat Belt --> Front Seat Belt --> Removal and Installation:

SEAT BELT

FRONT SEAT BELT

REMOVAL AND INSTALLATION

CAUTION

SRS: Before removing and installing the seat belts with pre-tensioner, refer to GROUP 52B – SRS Service Precautions and Seat Belt with Pre-tensioner .

Pre-removal and Post-installation Operation

- Turn the ignition key to the LOOK (OFF) position.

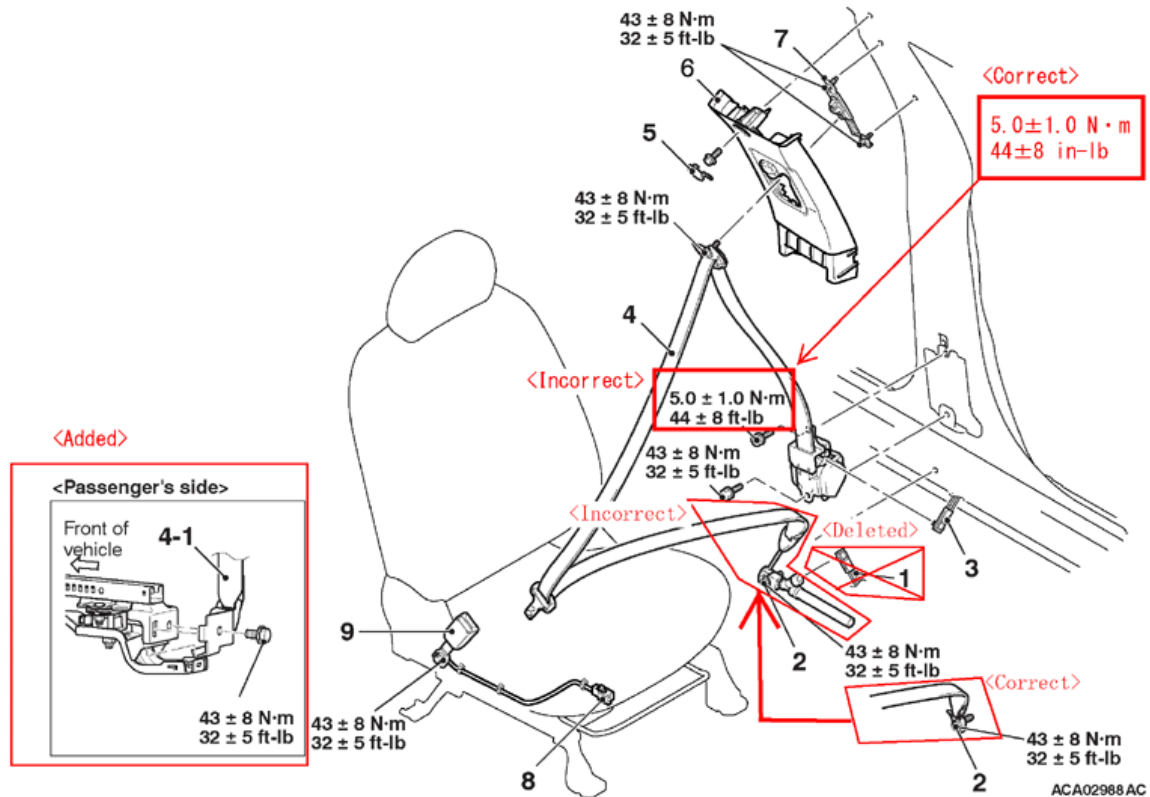

Outer seat belt removal steps

- Disconnect the negative (-) battery terminal.
- Lower center pillar trim.

- <Deleted>**
- ~~1. Lap pre-tensioner connector <Driver's seat belt> (GROUP 52B- Seat Belt with Pre-tensioner).~~
 2. Outer seat belt mounting bolt
 3. Seat belt pre-tensioner connector connection <Driver's seat belt> (GROUP 52B- Seat Belt with Pre-tensioner).

Outer seat belt removal steps **<Added>**

4. Outer seat belt assembly **<Driver's side>** (GROUP 52B - Seat Belt with Pre-tensioner).

- <Added>**
- 4-1. Outer seat belt assembly <Passenger's side> (GROUP 52B - Seat Belt with Pre-tensioner).

5. Center pillar trim cap
6. Center pillar trim upper.
7. Front seat belt anchor adjustable
8. **Inner seat belt removal steps**
 Harness connector (passenger's side)

Please make the following changes to the 2013 – 2015 Outlander Sport / RVR Service Manual, Group 52A – Interior --> Seat Belt --> Front Seat Belt --> Removal and Installation:

SEAT BELT

FRONT SEAT BELT

REMOVAL AND INSTALLATION

⚠ CAUTION

SRS: Before removing and installing the seat belts with pre-tensioner, refer to GROUP 52B – SRS Service Precautions and Seat Belt with Pre-tensioner .

Pre-removal and Post-installation Operation

- Turn the ignition key to the LOOK (OFF) position.

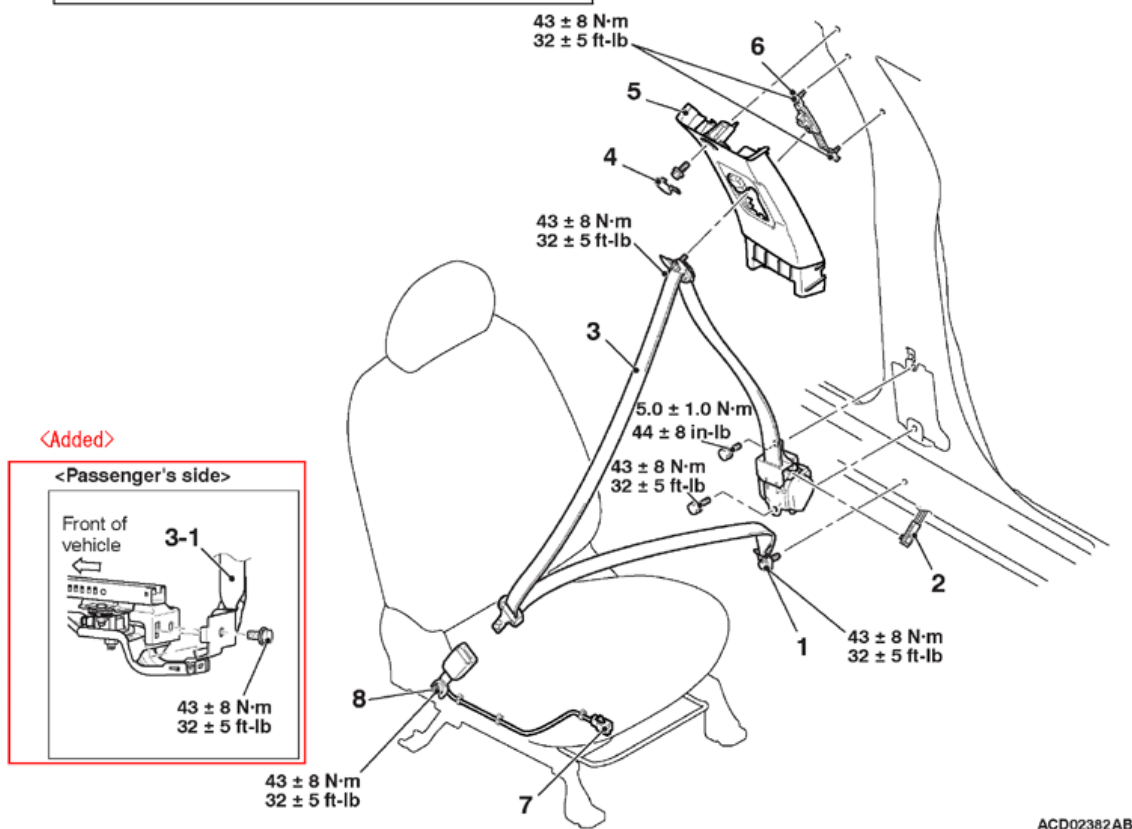

ACD02382AB

Outer seat belt removal steps

- Disconnect the negative (-) battery terminal.
- Lower center pillar trim.
- 1. Outer seat belt mounting bolt
- 2. Seat belt pre-tensioner connector connection <Driver's seat belt> (GROUP 52B- Seat Belt with Pre-tensioner).
- 3. Outer seat belt assembly <Driver's side> (GROUP 52B - Seat Belt with Pre-tensioner).

<<A>>

<Added>

Outer seat belt removal steps

- 3-1. Outer seat belt assembly <Passenger's side> (GROUP 52B - Seat Belt with Pre-tensioner).
 - 4. Center pillar trim cap
 - 5. Center pillar trim upper.
 - 6. Front seat belt anchor adjustable
- #### Inner seat belt removal steps
- 7. Harness connector (passenger's side)
 - Side shield cover.
 - 8. Inner seat belt.