

© 2014 Mazda Motor of America, Inc.

Subject: CREAK / SQUEAK NOISE FROM REAR WHEN DRIVING OVER BUMPS	Bulletin No: 02-002/14
	Last Issued: 07/11/2014

BULLETIN NOTE

- This bulletin supersedes the previous bulletin 02-001/11, issued on 04/18/2011, 02-007/10, issued on 12/10/2010 and 11/18/2010. The APPLICABLE MODEL(S)/VINS has been revised.
- Changes are noted below in Red beside the change bar.

APPLICABLE MODEL(S)/VINS

2011-2014 Mazda2

DESCRIPTION

Some vehicles may exhibit a creak/squeak type noise coming from the rear of the vehicle when driving over bumps. Noise may be caused by the rear shock absorber rod surface (A) sticking to the bump stopper (B) and/or the bump stopper sticking to the mounting base (C).

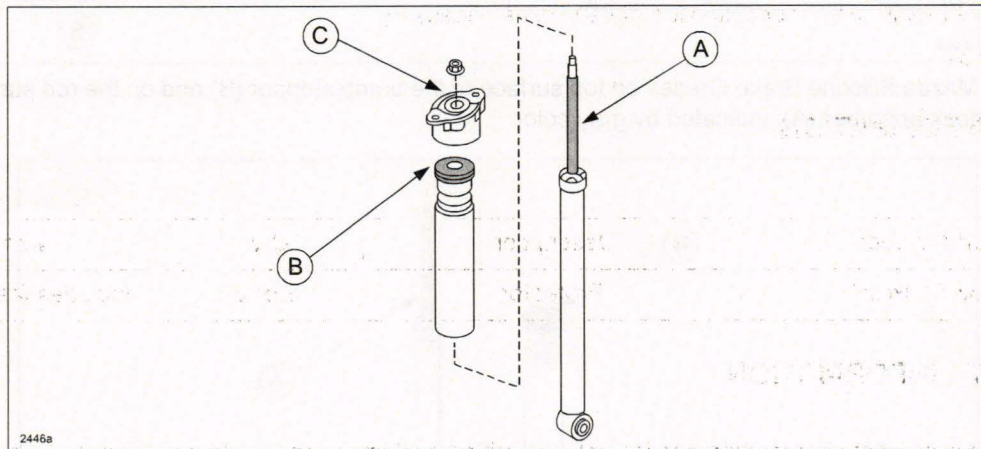

Customers having this concern should have their vehicle repaired using the following repair procedure.

REPAIR PROCEDURE

1. Verify customer concern.
2. Lift vehicle per MS3 online or Workshop Manual (section 00-00 JACKING POSITIONS, VEHICLE LIFT (2 SUPPORTS) AND SAFETY STAND (RIGID RACK) POSITIONS).
3. Apply Mazda Silicone Brake Grease on the top surface of the bump stopper and on the rod surface of the rear shock absorber. (Both LH and RH).
 - a. Separate the bump stopper (B) from the mounting case by pulling it down.

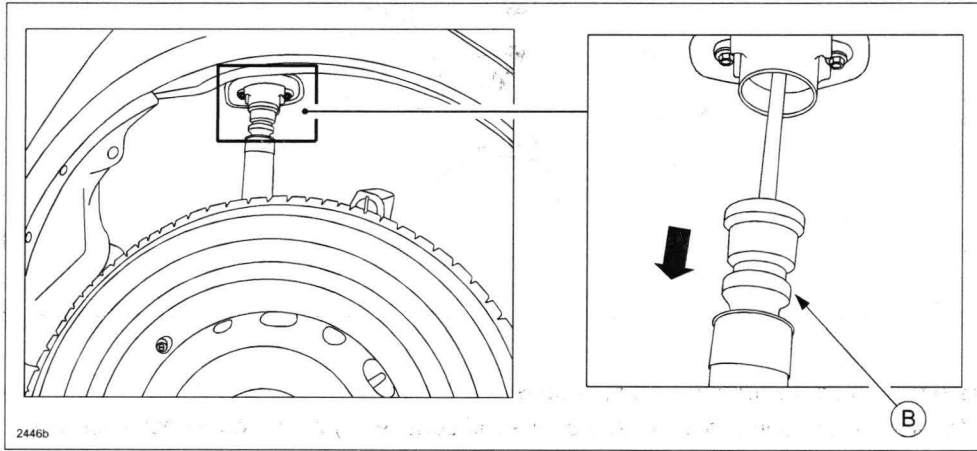

- b. Apply Mazda Silicone Brake Grease on top surface of the bump stopper (B) and on the rod surface of the rear shock absorber (A), indicated by gray color:

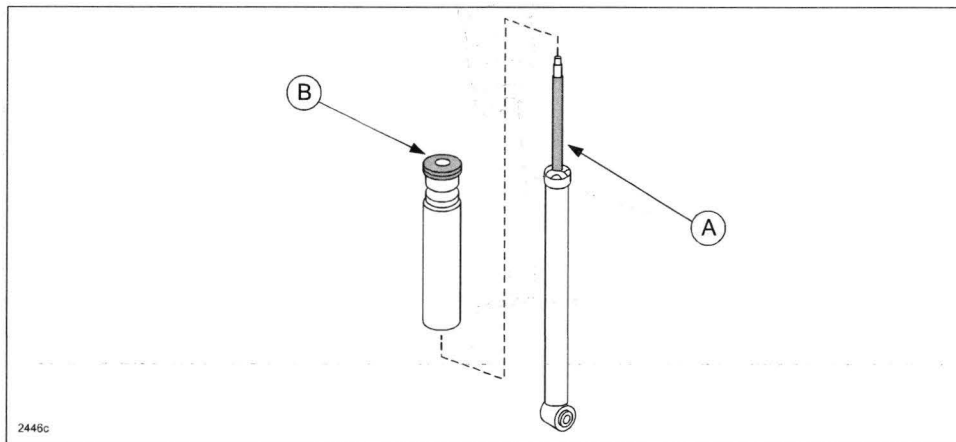

- c. Rotate the bump stopper (B) while lifting up until it makes contact with the mounting case.

NOTE: The installation requires less force and effort if the bump stopper is rotated and inserted to the mounting case simultaneously so that the grease can spread to the whole area where the bump stopper meets with the rod and /or the mounting case.

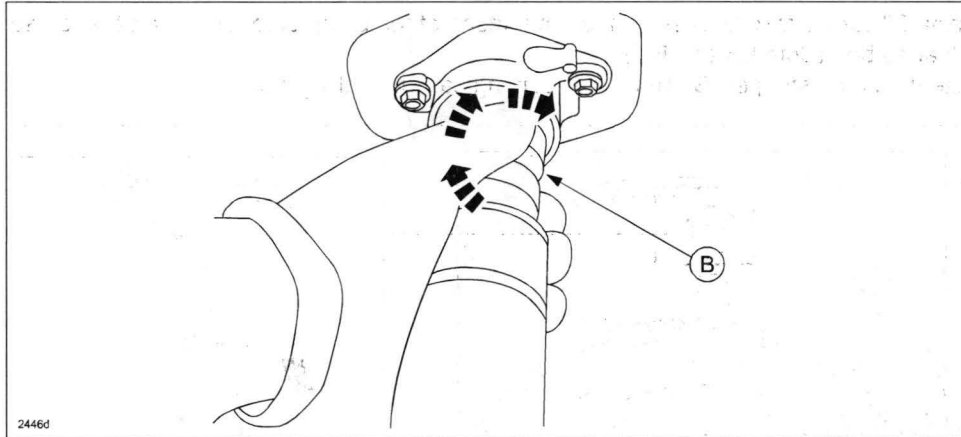

- d. Separate the dust cover from the bump stopper.
e. Apply the Mazda Silicone Brake Grease on the rod surface (A) of the rear shock absorber.

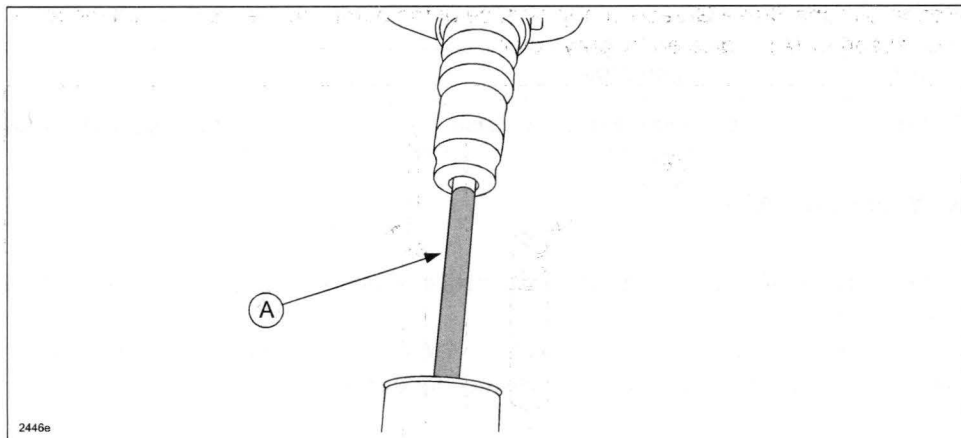

f. Install the dust cover back into the bump stopper.

NOTE: It requires less force and effort if the dust cover is rotated (A) and inserted to the bump stopper simultaneously.

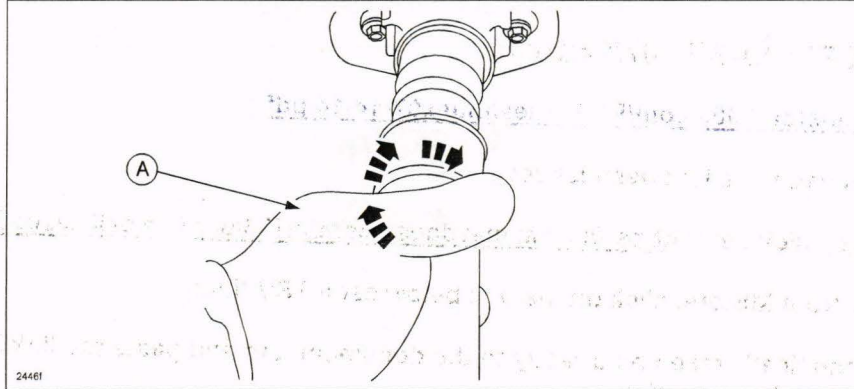

g. Lower the vehicle.

4. Verify repair.

PART(S) INFORMATION

Part Number	Description	Qty.	Notes
0000-77-XG3A	Mazda Silicone Brake Grease	1	Shop Supply (1 = multiple repairs)

WARRANTY INFORMATION

NOTE:

- This warranty information applies only to verified customer complaints on vehicles eligible for warranty repair.
- This repair will be covered under Mazda's New Vehicle Limited Warranty term.
- Additional diagnostic time cannot be claimed for this repair.

Warranty Type	A
Symptom Code	82
Damage Code	97
Part Number Main Cause	DR61-28-70X
Quantity	0
Operation Number / Labor Hours:	XXF4DXRX (both sides) / 0.3 Hrs.

NOTE: Brake Grease (0000-77-XG3A) is a shop supply and cannot be claimed under warranty.