

# Service Bulletin

Mazda North American Operations  
Irvine, CA 92618-2922



© 2014 Mazda Motor of America, Inc.

<b>Subject:</b> <b>STEERING WHEEL OFF CENTER WITHOUT DRIFT OR PULL</b>	<b>Bulletin No:</b> 02-004/14
	<b>Last Issued:</b> 11/4/2014

## BULLETIN NOTE

- This bulletin supersedes the previous bulletins 02-004/13 issued on 08/22/2013 and 04/10/2013, 02-004/12 issued on 09/19/2012 and 02/19/13, 02-005/10 issued on 03/26/10 and 11/05/10. The APPLICABLE MODEL(S)VINS have been revised.
- Changes are noted below in Red beside the change bar.

## APPLICABLE MODEL(S)/VINS

2011-2014 Mazda2	2013-2016 CX-5	2006-2015 MX-5
2004-2015 Mazda3	2007-2012 CX-7	2004-2011 RX-8
2006-2014 Mazda5	2007-2015 CX-9	2001-2011 Tribute
2003-2016 Mazda6		

## DESCRIPTION

Some customers may complain that the steering wheel is off center more than 3° even when driving straight on a flat road.

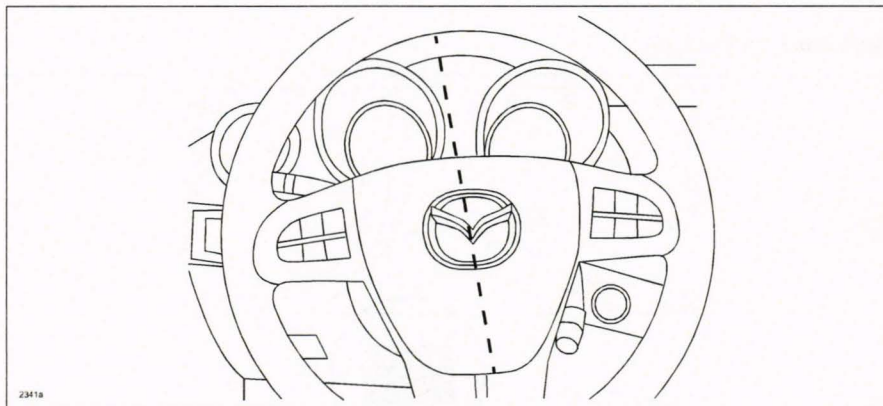

Customers having this concern should have their vehicle repaired using the following repair procedure.

**CONSUMER NOTICE:** The information and instructions in this bulletin are intended for use by skilled technicians. Mazda technicians utilize the proper tools/equipment and take training to correctly and safely maintain Mazda vehicles. These instructions should not be performed by "do-it-yourselfers." Customers should not assume this bulletin applies to their vehicle or that their vehicle will develop the described concern. To determine if the information applies, customers should contact their nearest authorized Mazda dealership. Mazda North American Operations reserves the right to alter the specifications and contents of this bulletin without obligation or advance notice. All rights reserved. No part of this bulletin may be reproduced in any form or by any means, electronic or mechanical---including photocopying and recording and the use of any kind of information storage and retrieval system ---without permission in writing.

## REPAIR PROCEDURE

1. Verify customer concern and make sure there is no drift or pull concern.
  - If the steering is pulling to the right or the left, this procedure does not apply. Refer to MS3 online instructions for troubleshooting.
2. Measure the offset using "Measurement of Steering Wheel Offset."
  - If the offset is  $3^\circ$  or less, it is considered normal.
  - If the offset is more than  $3^\circ$ , adjust the steering wheel center using "Adjustment of Steering Wheel Center."
3. Verify repair.

### Measurement of Steering Wheel Offset

1. Visually align the steering wheel to its center, then apply tape on the steering wheel and the steering column cover.

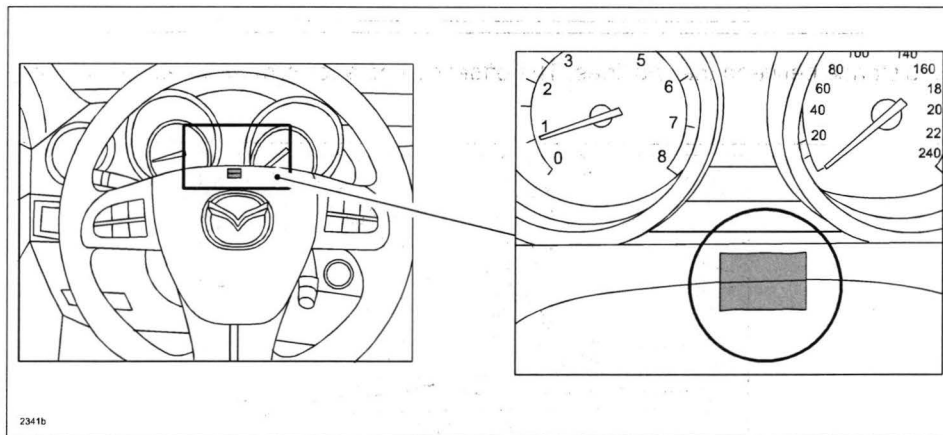

2. Put an alignment mark on the tape.

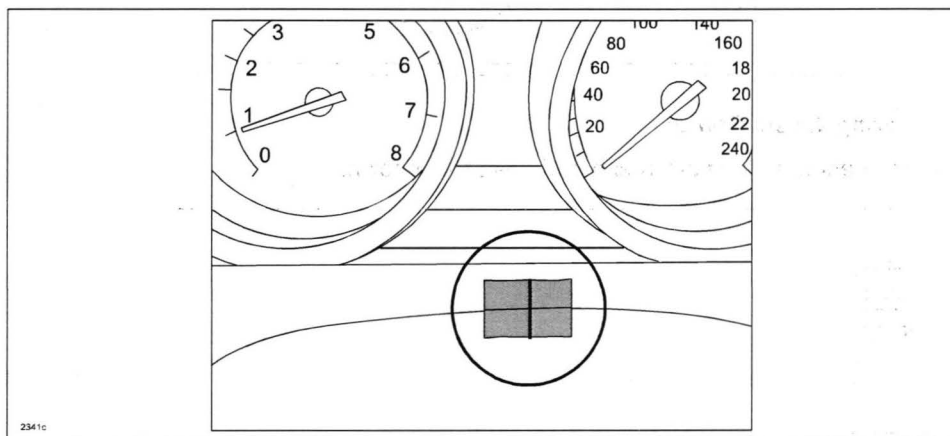

3. Drive the vehicle and align the steering wheel to its driving center, then put another mark on the tape.

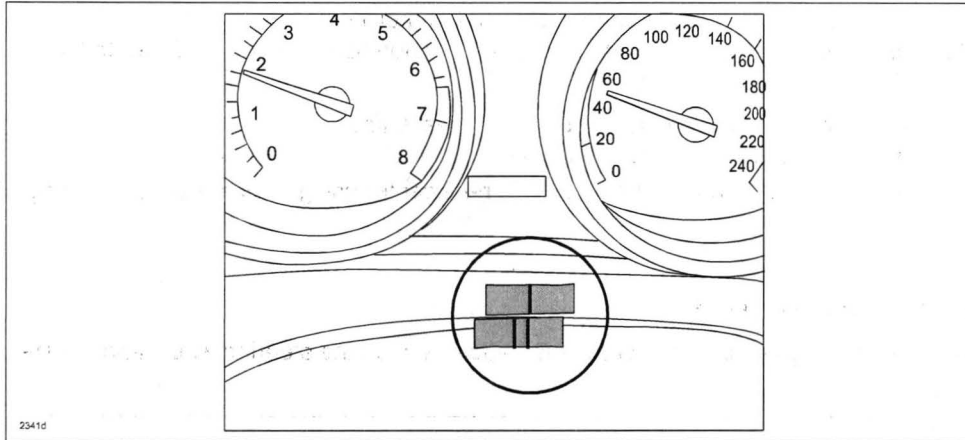

4. Measure the distance between the two lines. The offset can be approximately calculated using  $1\text{mm} = 1^\circ$  of offset.

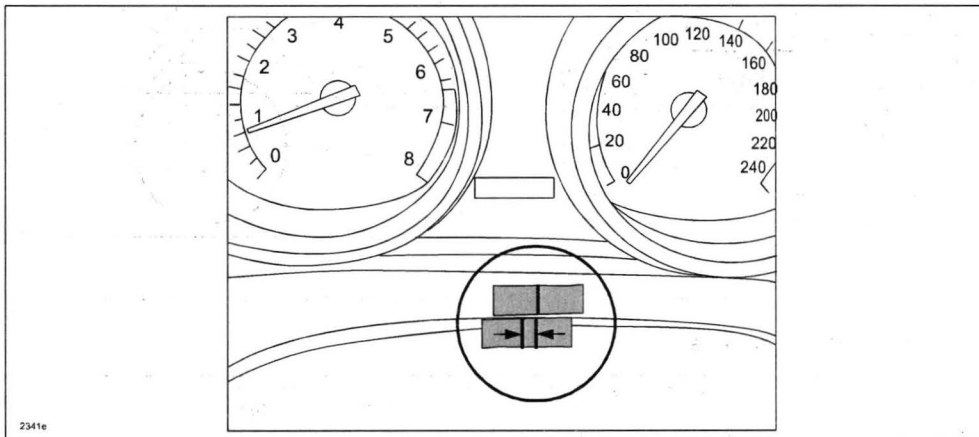

### Adjustment of Steering Wheel Center

1. Put an alignment mark over the tie-rod end and tie-rod as shown.

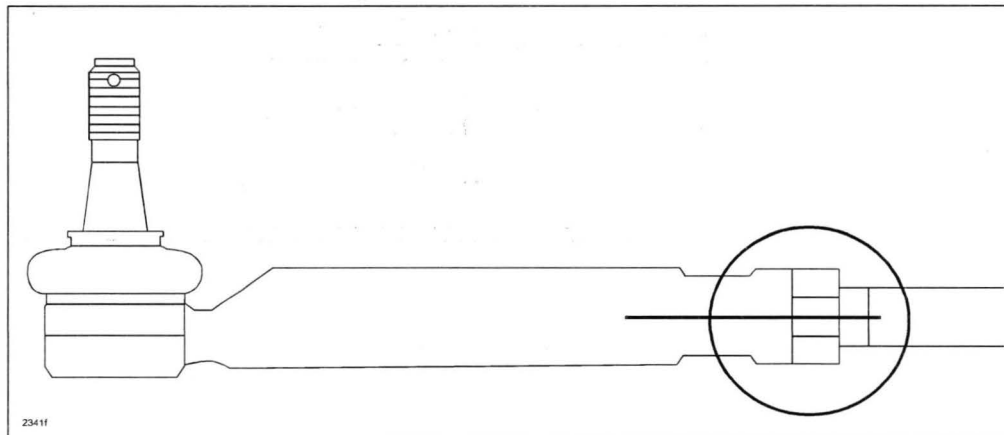

2. Remove the boot clamp (A), then loosen the lock nut (B).

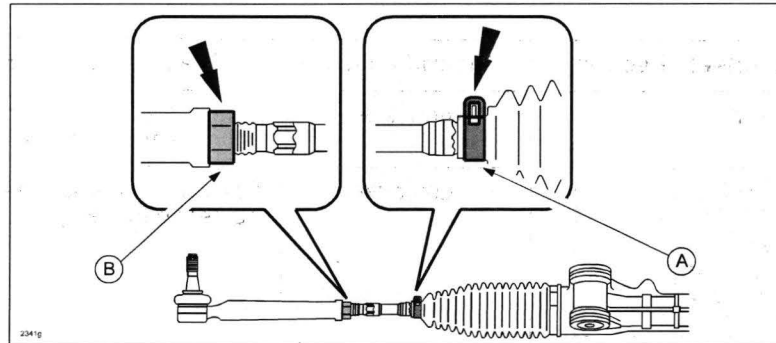

3. Rotate the tie-rod to adjust the steering wheel center. Refer to the following charts for rotating direction.

**NOTE:** Rotate both sides of the tie-rod by the same amount.

**- Steering wheel offset direction and tie-rod rotating direction -**

FRONT WHEEL DRIVE (Vehicles with steering gear mounted to the rear side of the front axle)

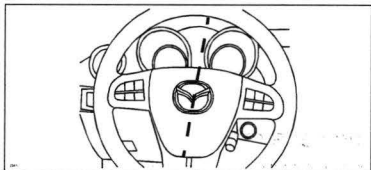
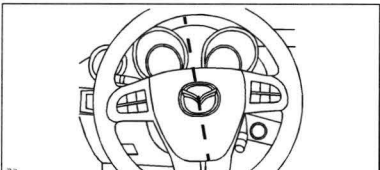
Steering wheel offset direction	Tie-rod adjust	Tie-rod rotating direction to adjust
Right 	Right side	Tighten the tie-rod towards the tie-rod end to decrease the length of the tie-rod.
	Left side	Loosen the tie-rod from the tie-rod end to increase the length of the tie-rod.
Left 	Right side	Loosen the tie-rod from the tie-rod end to increase the length of the tie-rod.
	Left side	Tighten the tie-rod towards the tie-rod end to decrease the length of the tie-rod.

REAR WHEEL DRIVE (Vehicles with steering gear mounted to the front side of the front axle)

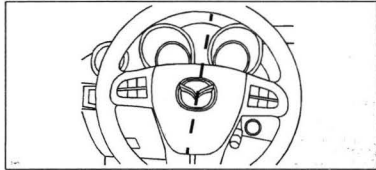
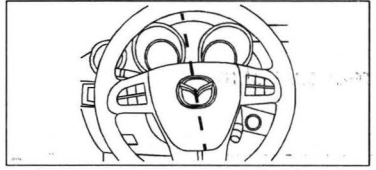
Steering wheel offset direction	Tie-rod adjust	Tie-rod rotating direction to adjust
Right 	Right side	Loosen the tie-rod from the tie-rod end to increase the length of the tie-rod.
	Left side	Tighten the tie-rod towards the tie-rod end to decrease the length of the tie-rod.
Left 	Right side	Tighten the tie-rod towards the tie-rod end to decrease the length of the tie-rod.
	Left side	Loosen the tie-rod from the tie-rod end to increase the length of the tie-rod.

- A: Tie-rod
- B: Lock nut
- C: Tie-rod end
- F: Front of vehicle

- 1: Turn in this direction to loosen the tie-rod from the tie-rod end and increase the length.
- 2: Turn in this direction to tighten the tie rod towards the tie-rod end and decrease the length.

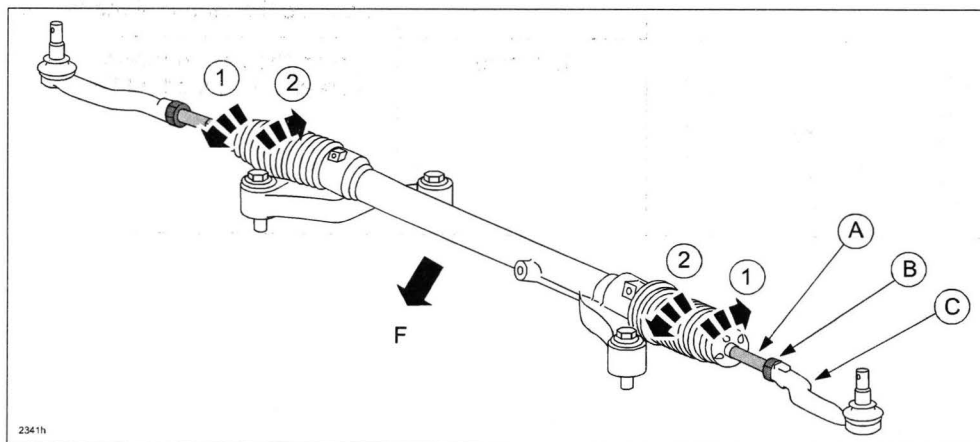

- (Reference) Steering wheel offset and tie-rod rotating angle -

Steering wheel offset to adjust	Tie-rod rotating angle
4 mm (approximately 4°)	150°
5 mm (approximately 5°)	180° (half turn)
6 mm (approximately 6°)	210°
7 mm (approximately 7°)	240°

4. Tighten the lock nut. Refer to MS3 online instructions for the tightening torque.
5. Straighten the boot, then attach the boot clamp.
6. Verify repair.

**WARRANTY INFORMATION**

**NOTE:**

- This warranty information applies only to verified customer complaints on vehicles eligible for warranty repair.
- This repair will be covered under Mazda's Service Adjustment Warranty term (12 months/12,000 miles).
- Additional diagnostic time cannot be claimed for this repair.
- This Service Bulletin cannot be combined with a wheel alignment.

Warranty Type	A
Symptom Code	30
Damage Code	9H
Part Number Main Cause	5555-FE-001
Quantity	0
Operation Number / Labor Hours:	XXF11XAX / 0.4 Hrs.