



Mercedes-Benz

MERCEDES-BENZ USA, LLC
One Mercedes Drive, P.O. Box 740, Northbrook, IL 60062-0740
Phone (201) 573-0600
Fax (201) 573-0117
MBUSA.com

Service

newschannel update

TO: Mercedes-Benz Dealer Principals, General Managers, Sales Managers, Service Managers, Parts Managers	FROM: Thomas Brunner, Department Manager, Vehicle Compliance and Analysis, Engineering Services
RE: : Recall Campaign 2012100001 - Replace Refrigerant R1234yf with R134a, Model 231 (SL), Model Year 2013	DATE: October 26, 2012

IMPORTANT RECALL INFORMATION

This Recall Campaign is being launched today and the 432 affected vehicles are flagged in VMI.

On Friday, September 28, 2012 dealers were notified that Mercedes-Benz USA, LLC (MBUSA) will conduct a voluntary Recall Campaign on certain Model Year 2013 SL Class (231) vehicles to replace the Air Conditioning Refrigerant R1234yf. This notification is posted on the NHTSA web site and may generate some customer questions.

Background

Due to the findings of a recent DAG test program that replicated demanding operating conditions and corresponding engine temperatures, DAG has determined that the refrigerant R1234yf used in the climate control system may ignite in the engine compartment in the event of a severe frontal impact that would also cause a rupture to the refrigerant line. Therefore, Mercedes-Benz USA, LLC (MBUSA) has initiated a recall of these vehicles. An authorized Mercedes-Benz dealer will remove the refrigerant R1234yf, change the required hoses and replace the refrigerant in subject vehicles with non-flammable R134a.

Given this notice, it is a violation of Federal law for a dealer to deliver any new or used Model Year 2013 SL-Class (231) equipped with refrigerant R1234yf covered by this notification in dealer inventory, for sale or lease, until the vehicle has been repaired.

Parts - A Dealer allocation of one set of required parts per affected dealer will arrive at the dealer by launch date. Dealers may order additional parts as required, however parts are in very limited supply and should not be ordered for shelf stock. Parts replacement rate is 100%.

Owner Notification - Owner notifications will be sent approximately one week after recall launch.

A copy of the campaign bulletin is attached, and may also be found on StarTekInfo.

When scheduling customers for an appointment please ensure that you are aware of any open campaigns in VMI so that the customer is advised about the time necessary to complete all campaigns.



Mercedes-Benz - are registered trademarks of Daimler, Stuttgart, Germany



Mercedes-Benz

MERCEDES-BENZ USA, LLC

One Mercedes Drive, P.O. Box 700, Montvale, NJ 07645-0380
Phone (201) 573-0300
Fax (201) 573-0377
MBUSA.com

Service

newschannel update

Note: VMI must always be checked before performing campaigns to verify that the campaign is required on a specific vehicle.

Dealers may also identify vehicles subject to a campaign through NetStar by selecting "Campaign" under the Controlling tab. Only vehicles that have been retailed by the respective dealer will be displayed within this program.

While we regret any inconvenience this causes, Mercedes-Benz USA, LLC is determined to maintain a high level of vehicle quality and customer satisfaction.

Please refer all customer inquiries to the Customer Assistance Center at 1-800-FOR_MERCEdes (1-800-367-6372).



Campaign No. 2012100001, October 2012

TO: ALL MERCEDES-BENZ CENTERS

SUBJECT: **Model 231, Model Year 2013**
Replace Refrigerant R1234yf with Refrigerant R134a

Daimler AG (DAG), the manufacturer of Mercedes-Benz vehicles, has determined that the climate control refrigerant R1234yf used in Model Year 2013, Model 231 (SL) vehicles, must be replaced. Due to the findings of a recent DAG test program that replicated demanding operating conditions and corresponding engine temperatures, DAG has determined that the refrigerant R1234yf used in the climate control system may ignite in the engine compartment in the event of a severe frontal impact that would also cause a rupture to the refrigerant line. Therefore, Mercedes-Benz USA, LLC (MBUSA) has initiated a recall of these vehicles. An authorized Mercedes-Benz dealer will remove the refrigerant R1234yf, change the required hoses and replace the refrigerant in subject vehicles with non-flammable R134a.

Attached is a sample copy of a letter which owners of the affected vehicles will receive.

Prior to performing this Recall Campaign:

- Please check VMI to determine if the vehicle is involved in the Campaign and if it has been previously repaired.
- Please review the entire Recall Campaign bulletin and follow the repair procedure exactly as described.

Please note that Recall and Service Campaigns **do not expire** and may also be performed on a vehicle with a vehicle status indicator.

Approximately 432 vehicles are involved.

Order No. P-RC-2012100001

This bulletin has been created and maintained in accordance with MBUSA-SLP S423QH001, Document and Data Control, and MBUSA-SLP S424HH001, Control of Quality Records.

Procedure



Danger! Risk of explosion caused by welding or soldering work on closed air conditioning system. **Risk of poisoning** caused by inhaling overheated refrigerant vapors. **Risk of injury** to skin and eyes caused by contact with liquid refrigerants. Never perform welding work on or near a closed air conditioning system. No smoking or open flames. Wear safety glasses and protective gloves. Work only in well ventilated areas. Carry out repair work on the air conditioning system circuit only after the system has been emptied. **Refer to WIS:** AS83.00-Z-0001-01A

Note:

- Procedure for a damaged or leaky air conditioning system. Refer to WIS: AH83.30-P-0005-01A. It is not necessary to replace the receiver dryer for this procedure
- Notes for handling refrigerant **R1234yf**: Refer to WIS: AH83.30-P-0003-02A
- Notes for handling refrigerant **R134a**: Refer to WIS: AH83.30-N-0003-01A
- Protect air conditioning circuit and components from moisture when carrying out repair work: Refer to WIS: AH83.30-P-0005-01A

A. Evacuate A/C System and Install New Owner's Literature

1. Evacuate refrigerant R1234yf, refer WIS: AR83.30-P-1760YF.

Note:

- Do **not** remove refrigerant oil from A/C system.
 - If you are notified during the evacuation phase that the R1234yf Service Unit storage bottle is full, please contact Mike Roth at mbtoolsandequipment@mbusa.com to schedule a service unit refrigerant evacuation.
2. Install new operator's manuals:

Note: Install new operator's manuals while refrigerant is being evacuated.

 - Connect battery charger.
 - Replace printed operator's manual in vehicle's portfolio with **new** (printed) operator's manual
 - Load new digital operator's manual into COMAND.
 - Replace operator's manual CD in vehicle's portfolio with new (operator's manual) CD.
 - Disconnect battery charger.

B. Replace Refrigerant Lines for Condenser and Compressor Between Connection Point

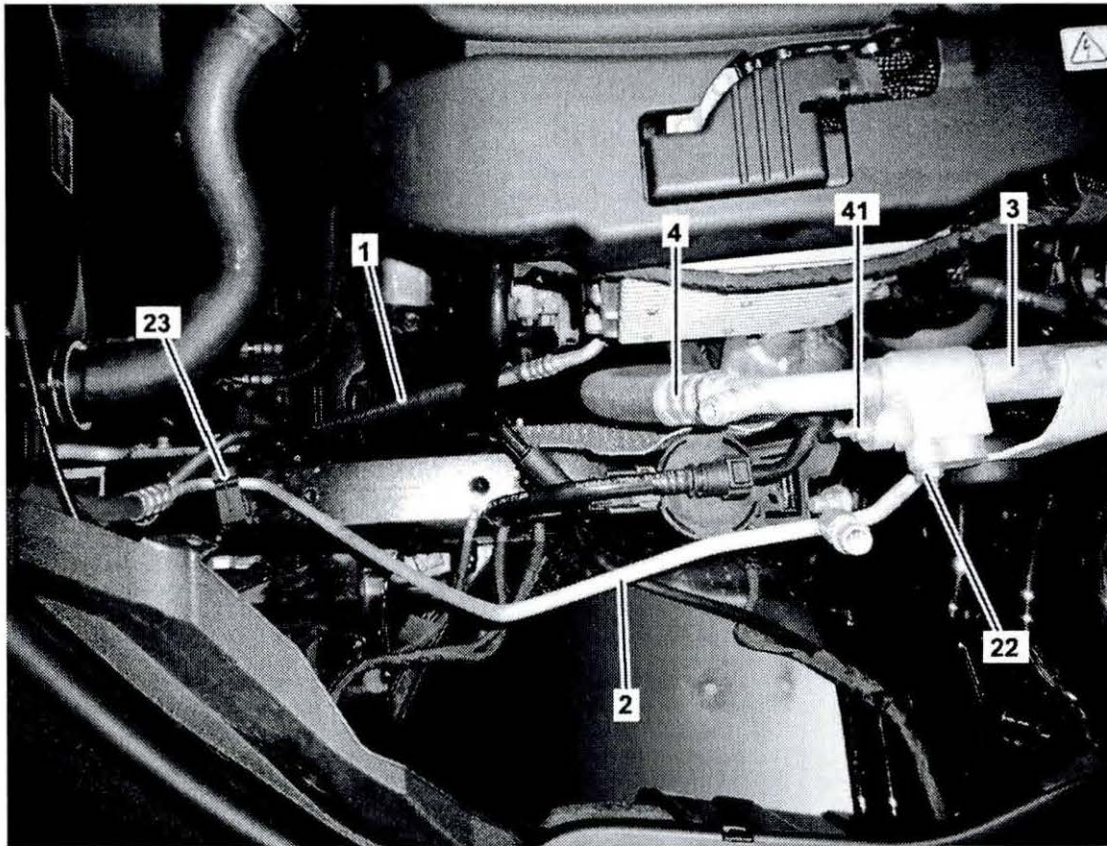

Figure 1

1	High pressure refrigerant line	22	Nut
2	Condenser refrigerant line	23	Condenser refrigerant line mounting clip
3	Low pressure refrigerant line (to evaporator).	41	Nut
4	Low pressure refrigerant line (to compressor).		

1. Remove nut (41, Figure 1).
 - Torque nut (41) to 8 Nm when installing.
2. Disconnect refrigerant line (4, Figure 1) from refrigerant line (3).
3. Remove nut (22, Figure 1).
 - Torque nut (22) to 8 Nm when installing
4. Disconnect condenser refrigerant line (2, Figure 1) from mounting clip (23).
5. Disconnect condenser refrigerant line (2, Figure 1) from refrigerant line (3).

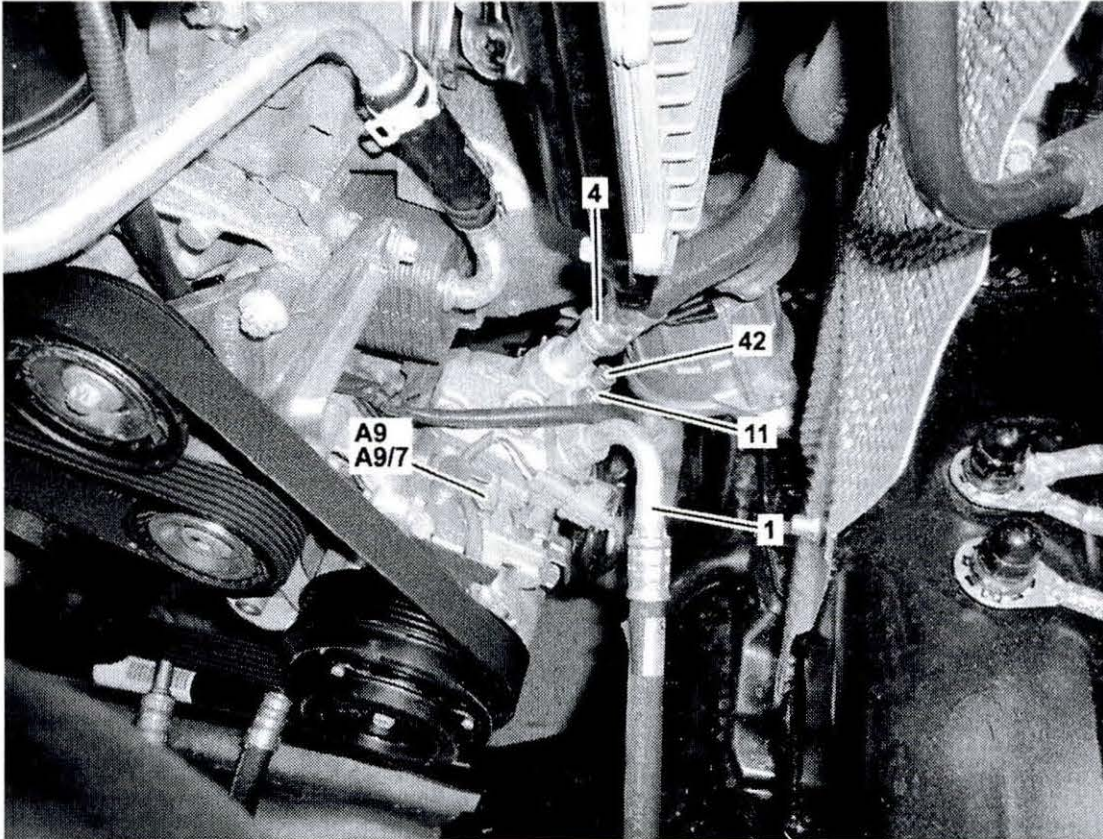

Figure 2

6. Remove lower front engine cover, refer to WIS AR61.20-P-1105RK.
7. Remove compressor refrigerant line bolt (42, Figure 2).
 - Torque bolt (42) to 20 Nm when installing.
8. Disconnect compressor refrigerant line (4, Figure 2) from compressor (A9, A9/7).
9. Remove compressor refrigerant line (4, Figure 2).
10. Install **new** compressor refrigerant line (4, Figure 2) in reverse order.

Note:

New refrigerant line should be provided with new O-rings already installed. Be careful not to damage O-rings when routing refrigerant line during installation. Lubricate O-rings with refrigerant oil prior to installing refrigerant line.

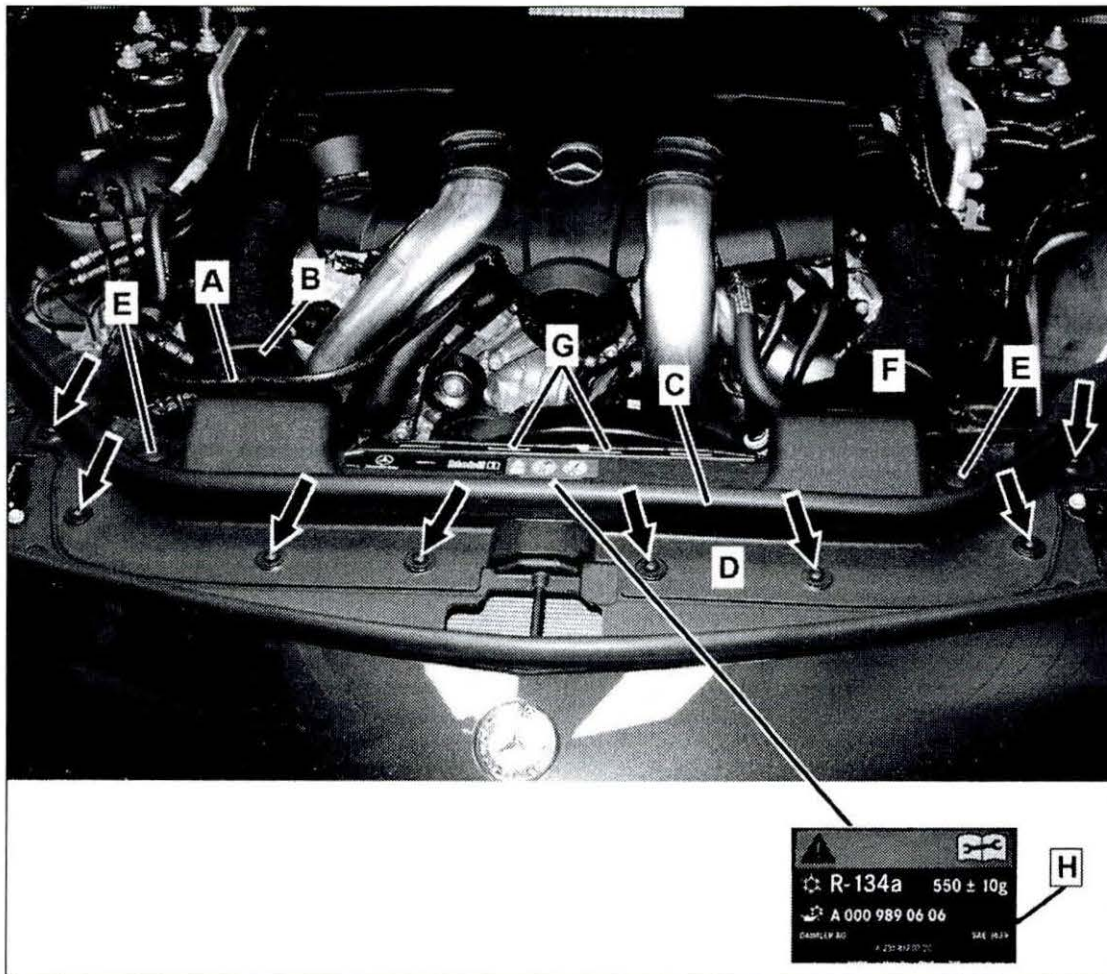

Figure 3

11. Remove radiator support/cover:

- Unclip coolant line (A, Figure 3) from air intake duct (B).
- Remove engine compartment seal (C, Figure 3) from radiator support/cover (D).
- Remove 2 radiator fasteners (E, Figure 3)
- Disconnect air intake ducts (B, F Figure 3) from radiator support/cover (D).
- Unclip hood release cable (G, Figure 3) from radiator (D).
- Remove radiator support/cover screws (arrows, Figure 3).
- Remove radiator support/cover (D, Figure 3).

12. Insert extension (A, Figure 4) with socket through radiator grill (arrow) and loosen condenser refrigerant line bolt (B, Figure 6).
 - Torque bolt (B, Figure 6) to 8 Nm when installing.

Note:

Be careful not to damage bumper or grill when loosening bolt.

13. Open clip (arrow, Figure 5) on top of radiator side shroud (A) and separate side shroud (A) from radiator assembly (B).

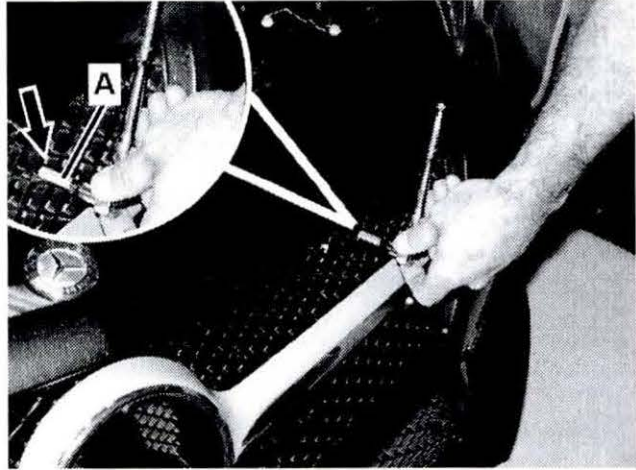

Figure 4

14. Carefully pull radiator assembly (A, Figure 6) in direction of arrows (Figure 6) then remove condenser refrigerant line bolt (B)
15. Route condenser refrigerant line (C, Figure 6) out through opening (arrow, Figure 7) in radiator side shroud (24, Figure 7) and remove from engine compartment.

Note:

Refer also to Figures 1 and 7 for more views of condenser components and refrigerant lines.

16. Install **new** condenser refrigerant line (C, Figure 6) in reverse order.

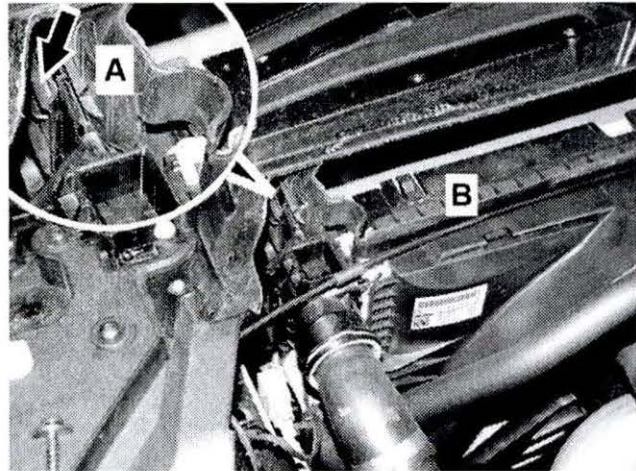

Figure 5

Note: New condenser refrigerant line should be provided with new O-rings already installed. Be careful not to damage O-rings when routing refrigerant line during installation. Lubricate O-rings with refrigerant oil prior to installing refrigerant line.

17. Assemble in reverse order.
18. Recharge air conditioning **with R134a** refrigerant **ONLY** and include 40 cc of refrigerant oil. Refer to WIS: AR83.30-P-1760NKB.
19. Replace information label for R-1234yf air conditioning filling capacity on radiator cross-member with **new R-134a** label (H, Figure 3).
20. Install new caps on A/C service valves of new refrigerant lines (2, 4, Figure 1).

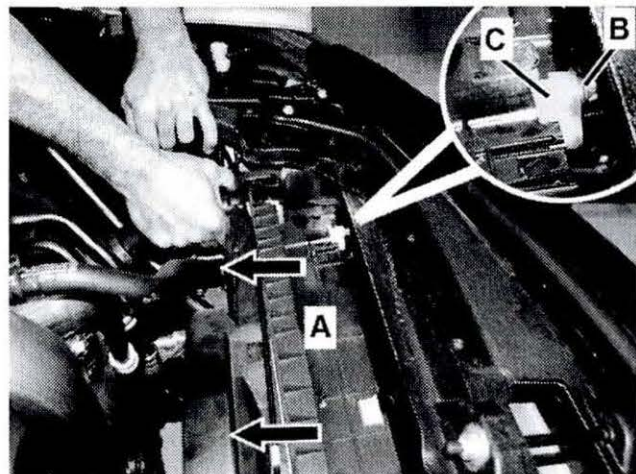

Figure 6

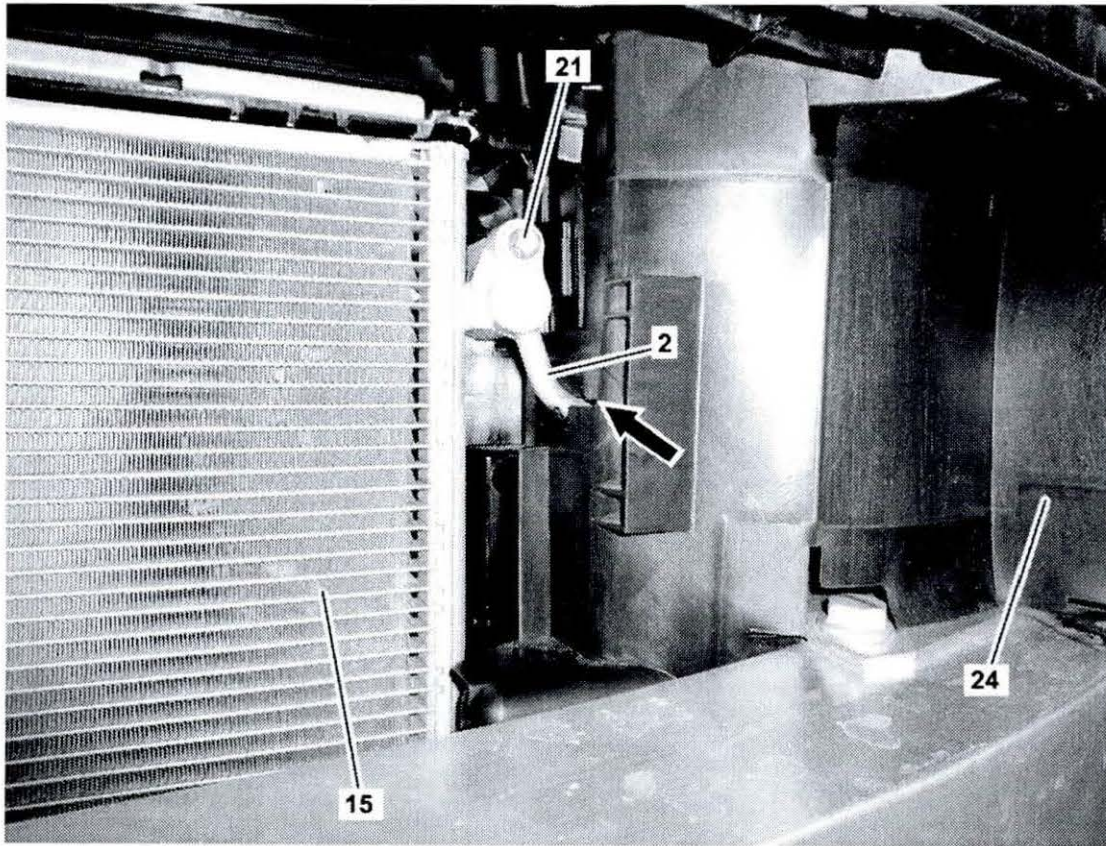
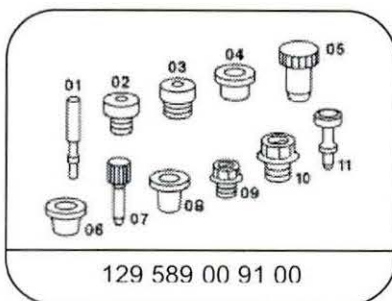

Figure 7 (shown from front of vehicle, behind radiator grill)

- 2 Condenser refrigerant line
 - 15 Condenser
 - 21 Condenser refrigerant line bolt
 - 24 Radiator side shroud
- Arrow: Opening for refrigerant line

Special Tools



Set of Stop Plugs

Primary Parts Information

Qty.	Part Name	Part Number	Estimated Replacement Rate
Model 231.473			
1	Condenser and connecting point refrigerant line	A 231 830 03 15	100%
Model 231.474			
1	Condenser and connecting point refrigerant line	A 231 830 62 15	100%
Models 231.473/474			
1	Refrigerant line from connecting point to compressor	A 231 830 00 15	100%
1	Filler connection cap	A 140 988 00 35	
1	Filler connection cap	A 140 988 01 35	
1	Information label for air conditioning filling capacity	A 231 817 07 20	
1	Digital Owner's Manual	A231 584 25 81	
1	Operator's manual (print version)	A231 584 07 71	
1	Refrigerant R134a ¹⁾	BQ 4 83 0192	
1	Refrigerant oil ²⁾	BQ 1 13 0001	

¹⁾ R134a refrigerant Submit as local purchase RFR01536 qty 1.0, handling is included..

²⁾ A/C refrigerant oil Submit as local purchase COM00626 qty 1.0, handling is included.

Note:

- Please be aware that only the part number(s) referenced in the Campaign Bulletin is approved for use to repair the vehicle. Repairs performed using any other part(s) will not have been performed in accordance with the campaign. Accordingly, warranty claims submitted with reference to an improper part number(s) will be denied.
- The following allowable labor operation should be used when submitting a warranty claim for this repair:

Warranty Information

Operation: Replace refrigerant of air conditioning **Includes:** Replace information label and update operator's manuals (02-7881).
Connect/disconnect battery charger (02-5058).

Damage Code	Operation Number	Model Indicator(s)
83 941 35 7	02-7881	1R, 1S
	02-5058	

Note

Operation code times are subject to change. Please refer to StarTime for current labor times



Mercedes-Benz

Mercedes-Benz USA, LLC

Urgent Safety Recall # 201210001
Replace Climate Control System Refrigerant
NHTSA Recall # 12V-478

Gareth Joyce
Vice President
Customer Services

November, 2012

Dear Mercedes-Benz Owner,

This notice is sent to you in accordance with the requirements of the National Traffic and Motor Vehicle Safety Act.

Daimler AG (DAG), the manufacturer of Mercedes-Benz vehicles, has decided that a defect which relates to motor vehicle safety exists in certain Model Year 2013 SL-Class vehicles with regard to the refrigerant used in your climate control system. Our records indicate that your vehicle is included in the affected population of vehicles.

WE SENT YOU THIS NOTICE BECAUSE WE ARE CONCERNED ABOUT YOUR SAFETY.

Due to the findings of a recent DAG test program that replicated demanding operating conditions and corresponding engine temperatures, DAG has determined that the refrigerant used in your climate control system may ignite in the engine compartment in the event of a severe frontal impact that would also cause a rupture to the refrigerant line. Therefore, Mercedes-Benz USA, LLC (MBUSA) has initiated a recall of these vehicles. An authorized Mercedes-Benz dealer will remove the refrigerant, change the required hoses and replace the refrigerant with a non-flammable product.

This service will be provided free of charge. The working time required is approximately 2 hours. As a matter of normal service process, an authorized Mercedes-Benz dealer will also check for other repair measures which might be applicable to your vehicle and this may increase the required working time.

Please contact **MERCEDES-BENZ OF ANYTOWN, 201-555-1234** or other authorized dealer, for additional information and to schedule an appointment at your earliest convenience. To locate additional authorized dealers please see www.MBUSA.com/dealerlocator. Please mention Recall Campaign #201210001.

If you are no longer the vehicle owner, or have a change of address, please complete the reverse side of this letter and return the complete letter in the enclosed envelope. If this is a leased vehicle and the lessor and registered owner receive this notice, please forward this information by first class mail to the lessee within 10 days to comply with federal regulations.

Please contact an authorized Mercedes-Benz dealer should you have any questions or encounter any difficulty regarding this recall. If a dealer is unable to remedy your situation please contact us at 1-(800) FOR-MERCEdes (1-800-367-6372).

If an authorized Mercedes-Benz dealer or MBUSA, LLC, fails or is unable to perform this service without charge within 60 days, pursuant to law 49 U.S.C. Chapter 301, you may submit a complaint to the Administrator, National Highway Traffic Safety Administration, 1200 New Jersey Avenue, S.E., Washington, D.C. 20590 or call the toll-free Auto Safety Hotline at 1-888-327-4236 (TTY 1-800-424-9153); or go to <http://www.safercar.gov>.

We apologize for any inconvenience this situation may cause you.

Sincerely,

Mercedes-Benz USA, LLC
One Mercedes Drive
P.O. Box 350
Montvale, NJ 07645-0350
Phone 1-800-FOR-MERCEdes (1-800-367-6372)
Fax (201) 476-6211
www.MBUSA.com

IMPORTANT

IF FOR ANY REASON YOU DO NOT NOW OWN THIS VEHICLE OR HAVE A CHANGE OF ADDRESS, PLEASE COMPLETE THE SECTION BELOW, PLACE IN THE ENCLOSED ENVELOPE, AND DROP IN ANY MAIL BOX. IF POSSIBLE, PROVIDE THE NAME AND ADDRESS OF THE PRESENT OWNER SO THAT WE MAY CONTACT THEM.

- SCRAPPED
- STOLEN
- OTHER _____
- SOLD _____ I HAVE SOLD THE VEHICLE TO:
- MY NEW ADDRESS IS:

NAME _____

STREET _____ APT. _____

CITY _____ STATE _____ ZIP _____

PHONE _____

THANK YOU FOR YOUR COOPERATION

**** PLEASE DO NOT DETACH. RETURN COMPLETE LETTER ****
DO NOT USE THE ENCLOSED ENVELOPE FOR OTHER CORRESPONDENCE