

Back Door Garnish Loose or Broken

Service Category Vehicle Exterior

Section Exterior Panels/Trim

Market USA

Scion Supports ASE Certification 

Applicability

YEAR(S)	MODEL(S)	ADDITIONAL INFORMATION
2005 – 2010	tC	Plant Code(s): 0 WMI(s): JTK

<p>REVISION NOTICE</p> <p>July 31, 2013 Rev2:</p> <ul style="list-style-type: none"> • The Parts Information section has been updated. <p>March 12, 2013 Rev1:</p> <ul style="list-style-type: none"> • The Title, Introduction, and Parts Information sections have been updated. <p>Any previous printed versions of this bulletin should be discarded.</p>
--

Introduction

Some 2005 – 2010 model year tC vehicles may exhibit a condition where the back door garnish becomes loose, and in some cases continued usage of the loose garnish may result in breakage. Please follow the procedure contained in this bulletin, which supplements the Repair Manual, to replace the back door garnish if it is loose or broken.

Figure 1.

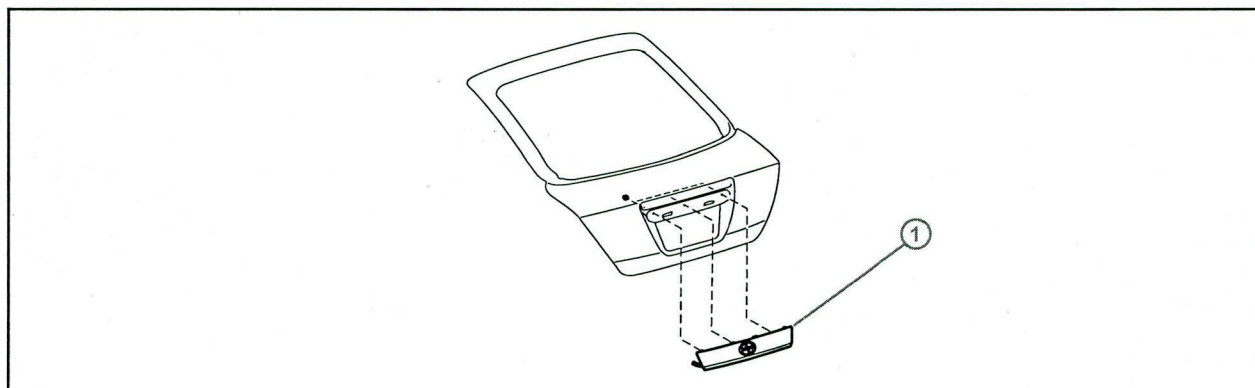

1	Back Door Garnish Sub-assembly Outside
---	--

Back Door Garnish Loose or Broken

Production Change Information

This bulletin applies to vehicles produced **BEFORE** the Production Change Effective VIN shown below.

MODEL	PLANT	PRODUCTION CHANGE EFFECTIVE VIN
tC	Tsutsumi	JTKDE3B7#A0305859

Warranty Information

OP CODE	DESCRIPTION	TIME	OFP	T1	T2
BD9058	R & R Garnish Sub-Assembly	0.4	76801-21070-##	62	12

APPLICABLE WARRANTY

- This repair is covered under the Toyota Comprehensive Warranty. This warranty is in effect for 36 months or 36,000 miles, whichever occurs first, from the vehicle's in-service date.
- Warranty application is limited to occurrence of the specified condition described in this bulletin.

Parts Information

NOTE

Before ordering the new Back Door Outside Garnish Sub-assembly, refer to the Color Code found on the Certification Label on the B-Pillar of the Driver Side Door.

Figure 2.

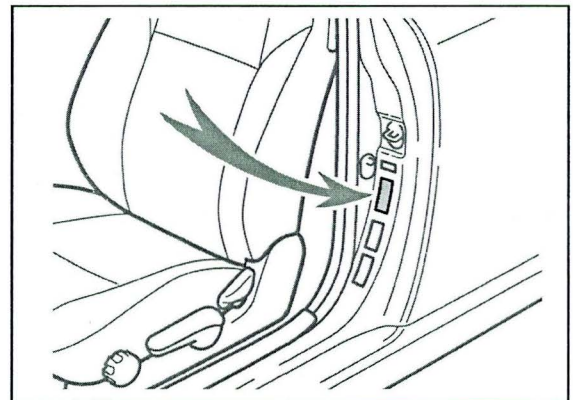

Back Door Garnish Loose or Broken

Parts Information (Continued)

PART NUMBER	COLOR CODE	COLOR DESCRIPTION	PART NAME	QTY
76801-21120-A0	040	Super White 2	Garnish Sub-Assembly, Back Door, Outside*	1
76801-21120-A1	070	Blizzard Pearl		
76801-21120-B0	1E0	Flint Mica		
76801-21120-B1	1E7	Silver Streak Mica		
76801-21120-B2	1F7	Classic Silver Metallic		
76801-21120-B3	1E9	Galactic Gray Mica		
76801-21120-C0	209	Black Sand Pearl		
76801-21120-C1	202	Black Onyx		
76801-21120-D0	3P2	Black Cherry (Bordeaux) Pearl		
76801-21120-D1	3P0	Absolutely Red		
76801-21120-D2	3R0	Sizzling Crimson Pearl		
76801-21120-J0	8P4	Indigo Ink Pearl		
76801-21120-J1	8Q6	Azure Blue Pearl		
76801-21120-J7	8S6	Nautical Blue Metallic		
76801-21120-J3	8Q1	Bright Blue Mica		
76801-21120-J8	8S7	Wave Line Pearl		
76801-21120-J5	8T5	Blue Ribbon Metallic		
76801-21120-J6	8P1	Speedway Blue Metallic		

* WITHOUT Back Door Opener Switch Assembly

PART NUMBER		PART NAME	QTY
PREVIOUS	NEW		
90179-05102	90080-17189	Nut, Flange	4

Required Tools & Equipment

SPECIAL SERVICE TOOLS (SST)	PART NUMBER	QTY
Plastic Pry Tool Set**	<u>00002-06020-01</u>	1

** Essential SST.

NOTE
 Additional SSTs may be ordered by calling 1-800-933-8335.

Back Door Garnish Loose or Broken

Repair Procedure

1. Using a plastic pry tool, detach the 8 claws and remove the back door garnish center.

Figure 3.

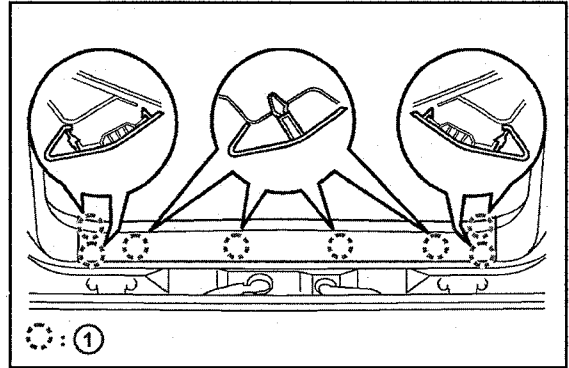

1 Claws

2. Using a plastic pry tool, detach the 6 claws and remove the left and right hand side back door garnish.

Figure 4.

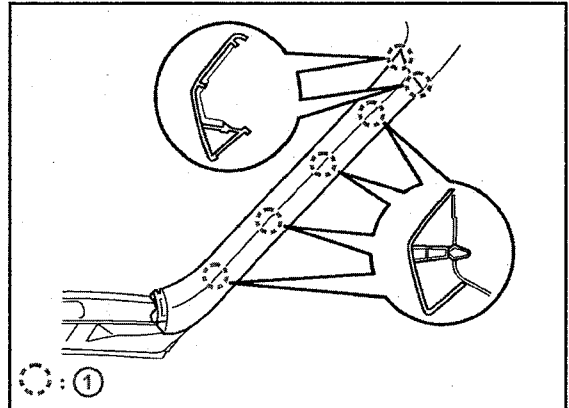

1 Claws

Back Door Garnish Loose or Broken

Repair Procedure (Continued)

3. Remove the back door trim board assembly.
 - A. Remove the 2 screws.
 - B. Using a plastic pry tool, detach the two upper clips.
 - C. Using a plastic pry tool, remove the 9 lower clips and remove the back door trim board assembly.

Figure 5.

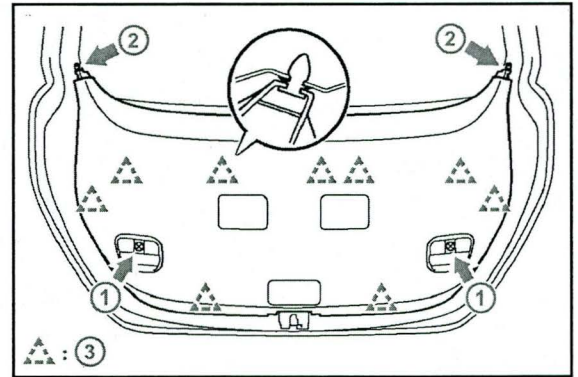

1	Screws
2	Upper Clips
3	Lower Clips

4. Remove the Back Door Outside Garnish Sub-assembly.

Figure 6.

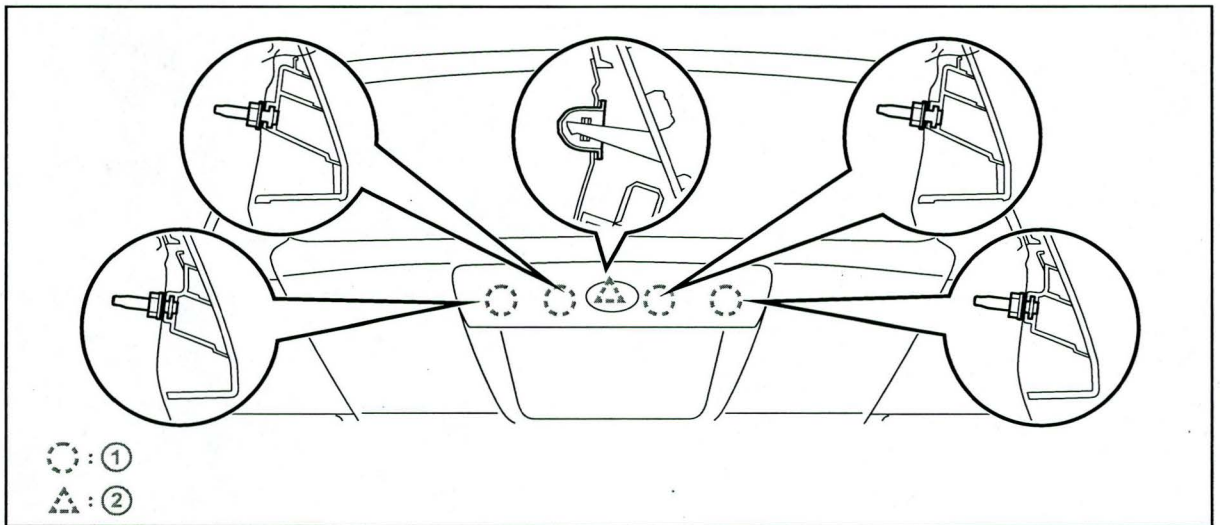

1	Nuts
---	------

2	Clip
---	------

- A. Remove the 4 nuts.
- B. Detach the clip and disconnect the connector. Then remove the garnish.

Back Door Garnish Loose or Broken

Repair Procedure (Continued)

5. Remove the 2 screws and the opener switch.

Figure 7.

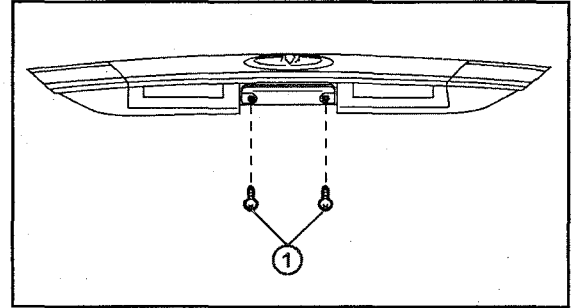

1	Screws
---	--------

6. Install the 2 screws and the opener switch in the NEW Back Door Garnish Sub-assembly (P/N 76801-21120-##).
7. Install the Back Door Outside Garnish Sub-assembly to the vehicle using the 4 nuts (P/N 90080-17189).

Torque: 4.9 N*m (49.9 kgf*cm, 43.5 in*lbf)

NOTICE

Do NOT use power tools during installation.

8. Reassemble vehicle in reverse order of disassembly steps 1 – 5.