

Engine Rattle/Noise on Cold Start-Up

Service
Category Engine/Hybrid System

Section Engine Mechanical

Market USA

Scion Supports
ASE Certification 

Applicability

YEAR(S)	MODEL(S)	ADDITIONAL INFORMATION
2012 – 2013	iQ	

Introduction

Some 2012 – 2013 model year iQ vehicles may exhibit one or more of the following conditions:

- Rattle type noise for first couple minutes following a cold start
- Excessive combustion chamber carbon build-up
- Idle speed momentarily drops to 500 rpm after a cold start

Follow the repair procedure in this bulletin to address these conditions.

Production Change Information

This bulletin applies to vehicles produced **BEFORE** the Production Change Effective VIN shown below.

MODEL	PLANT	DRIVETRAIN	PRODUCTION CHANGE EFFECTIVE VIN
iQ	Takaoka	CVT	JTNJJB0#DJ025093

Warranty Information

OP CODE	DESCRIPTION	TIME	OPF	T1	T2
EG1310	R & R Piston Sub-assembly with Pin (ALL), Piston Ring Set, and Oil Jets	15.6	13101-47021	91	43

APPLICABLE WARRANTY

- This repair is covered under the Toyota Powertrain Warranty. This warranty is in effect for 60 months or 60,000 miles, whichever occurs first, from the vehicle's in-service date.
- Warranty application is limited to occurrence of the specified condition described in this bulletin.

Engine Rattle/Noise on Cold Start-Up

Parts Information

PART NUMBER		PART NAME	QTY
PREVIOUS	NEW		
13011-47030 13011-47031	13011-47032	Ring Set, Piston*	1
13101-47020 13101-47021	13101-47022	Piston Sub-assy, w/Pin	4
15708-47040	15708-47031	Nozzle Sub-assy, Oil, No.1	4

* Parts listed are sets in quantities of 4, only order 1 of each.

Required Tools & Equipment

TOOLS & MATERIAL	QTY
FIPG Sealant: Three Bond 1207B, or Equivalent	As Needed
Piston Ring Expander	1
Piston Ring Compressor	1
Torque Wrench	1

SPECIAL SERVICE TOOLS (SST)	PART NUMBER	QTY
Piston Pin Press*	<u>09221-25026</u>	1

* Essential SST.

NOTE

Additional SSTs may be ordered by calling 1-800-933-8335.

Repair Procedure

1. Confirm condition as described in the Introduction.
2. Remove engine assembly.

Refer to the Technical Information System (TIS), applicable model and model year Repair Manual:

- 2012 / 2013 iQ:
Engine/Hybrid System – Engine Mechanical – “1NR-FE Engine Mechanical: Engine Unit: Removal”

Engine Rattle/Noise on Cold Start-Up

Repair Procedure (Continued)

- Disassemble engine assembly to gain access to the short block.

Refer to TIS, applicable model and model year Repair Manual:

- 2012 / 2013 iQ:
Engine/Hybrid System – Engine Mechanical – “1NR-FE Engine Mechanical: Engine Unit: Disassembly”

HINT

ONLY disassemble what is necessary for the parts being replaced.

- Disassemble short block.

Refer to TIS, applicable model and model year Repair Manual:

- 2012 / 2013 iQ:
Engine/Hybrid System – Engine Mechanical – “1NR-FE Engine Mechanical: Cylinder Block: Disassembly”

- Remove carbon deposits from all areas of combustion chamber, including cylinder head and short block.
- Replace the Pistons, Piston Ring set, and Oil Jets with updated parts.

NOTICE

Be sure to follow Figures 1 and 2 closely for proper ring installation and gap orientation.

Figure 1. Ring Identification

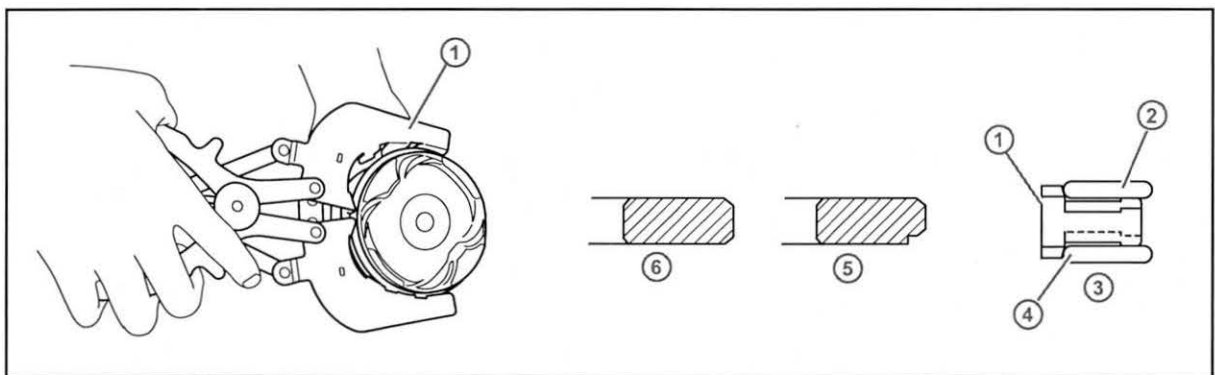

1	Piston Ring Expander
2	Upper Side Rail
3	Oil Ring

4	Lower Side Rail
5	No. 2 Ring
6	No. 1 Ring

Engine Rattle/Noise on Cold Start-Up

Repair Procedure (Continued)

Figure 2. Ring Alignment

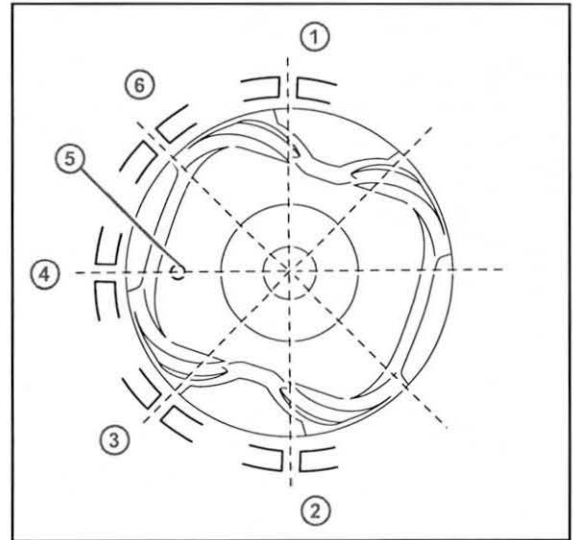

1	Lower Side Rail
2	Upper Side Rail
3	No. 1 Ring
4	Oil Ring Expander
5	Front Mark
6	No. 2 Ring

7. Reassemble short block.

Refer to TIS, applicable model and model year Repair Manual:

- 2012 / 2013 iQ:
Engine/Hybrid System – Engine Mechanical – “1NR-FE Engine Mechanical: Cylinder Block: Reassembly”

8. Reassemble and install engine assembly.

Refer to TIS, applicable model and model year Repair Manual:

- 2012 / 2013 iQ:
Engine/Hybrid System – Engine Mechanical – “1NR-FE Engine Mechanical: Engine Unit: Reassembly”
- 2012 / 2013 iQ:
Engine/Hybrid System – Engine Mechanical – “1NR-FE Engine Mechanical: Engine Unit: Installation”

9. Confirm repair.