

## Tony Lawrence

---

**From:** Tony Lawrence  
**Sent:** Tuesday, June 10, 2014 4:48 PM  
**To:** All Dirs All Rgns - PT; All Dirs All Rgns - SR  
**Subject:** MAZDA DEALER NOTICE - SERVICE BULLETIN RELEASE

### **SERVICE BULLETIN RELEASE - 06/10/2014**

2014 INDEX: [http://www.mstore2000.com/PDF\\_Files/index06-10-14.pdf](http://www.mstore2000.com/PDF_Files/index06-10-14.pdf)

The following Service Bulletin has just been issued.

- For latest MS3 postings, click here: <https://portal.mazdausa.com/m173/service/esi/MazdaServiceShop>

- For printable PDF files from MStore, click on the link below each TSB title:

\* If the links do not automatically take you directly to the document, cut and paste the link into your internet browser address window and press enter.

#### **NEW BULLETIN**

01-014/14 - MULTI-MODEL - CHECK ENGINE LIGHT ON WITH DTC P0456

[http://www.mstore2000.com/PDF\\_Files/01-014-14-2932.pdf](http://www.mstore2000.com/PDF_Files/01-014-14-2932.pdf)

#### **UPDATED BULLETINS**

00-002/14 - MULTI-MODEL - ON-CAR BRAKE LATHE

[http://www.mstore2000.com/PDF\\_Files/00-002-14-2936.pdf](http://www.mstore2000.com/PDF_Files/00-002-14-2936.pdf)

09-026/14 - 2013-2015 CX-5 - DRIVER-SIDE POWER DOOR MIRROR VIBRATION

[http://www.mstore2000.com/PDF\\_Files/09-026-14-2934.pdf](http://www.mstore2000.com/PDF_Files/09-026-14-2934.pdf)

09-027/14 - MULTI-MODEL - PROPER USAGE OF DRIVER'S FLOOR MAT

[http://www.mstore2000.com/PDF\\_Files/09-027-14-2935.pdf](http://www.mstore2000.com/PDF_Files/09-027-14-2935.pdf)

- Please distribute this information to all parts and service personnel.
- If you no longer wish to receive Mazda service bulletins, please contact the IT Administrator at your dealership and ask them to remove your email address from under the EMDCS application.

© 2014 Mazda Motor of America, Inc.

<b>Subject:</b>  CHECK ENGINE LIGHT ON WITH DTC P0456	<b>Bulletin No:</b> 01-014/14
	<b>Last Issued:</b> 06/10/2014

## APPLICABLE MODEL(S)/VINS

2011-2013 Mazda3

2007-2014 CX-9

## DESCRIPTION

Some vehicles may exhibit the check engine light on with DTC P0456 stored in the PCM memory.

- P0456: EVAP system leak detected (very small leak)

The concern is most likely the result of the customer not getting the fuel cap completely closed after fueling the vehicle. This causes a small fuel vapor leak and turns DTC P0456 on.

Customers having this concern should have their vehicle repaired using the following repair procedure.

## REPAIR PROCEDURE

1. Verify the customer concern (and that DTC P0456 is stored in the PCM memory).
2. Perform the workshop manual diagnosis procedures for DTC P0456.
  - If a leak is detected, repair it according to the instructions on MS3 online or the Workshop Manual.
  - If no leak is detected, the most probable cause is the fuel cap was not completely sealed (B).

### 2011-13 MAZDA3, 2007-14 CX-9:

#### NOTE:

- **DO NOT** replace any parts without detecting a leak using MS3 / Workshop Manual diagnostics.
- **Explain to the customer that the fuel cap must be turned at least 80 degrees (C) or until two (2) or more click sounds are heard (D) to be properly sealed.**
- If the fuel cap is not completely closed, it may stay in the B range, (because the C range is so small) and will likely leak.

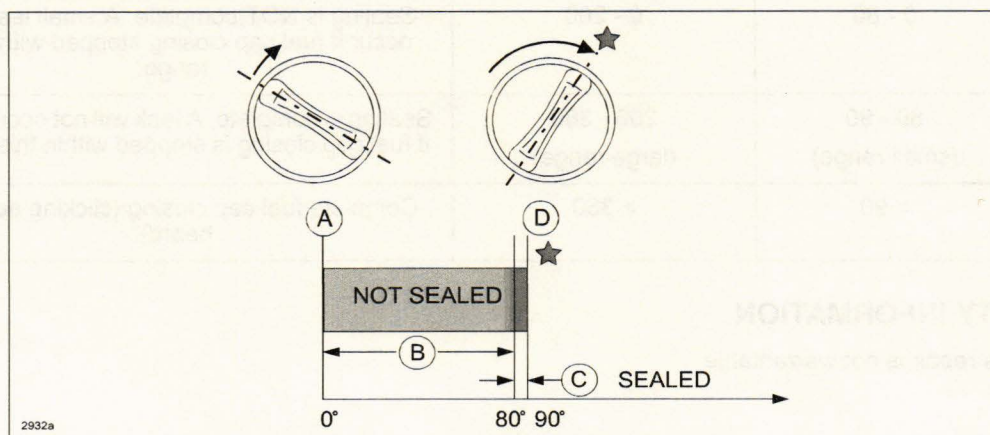

**2014-15 MAZDA3, 2013-15 CX-5, 2014-15 MAZDA6:**

**NOTE:**

- If the fuel cap is turned less than 200 degrees (B), it is not sealed.
- If the fuel cap is turned between 200 ~ 360 degrees (C), it is sealed.
- If the fuel cap is turned 360 degrees or more, it is sealed and a clicking noise (D) is also heard.

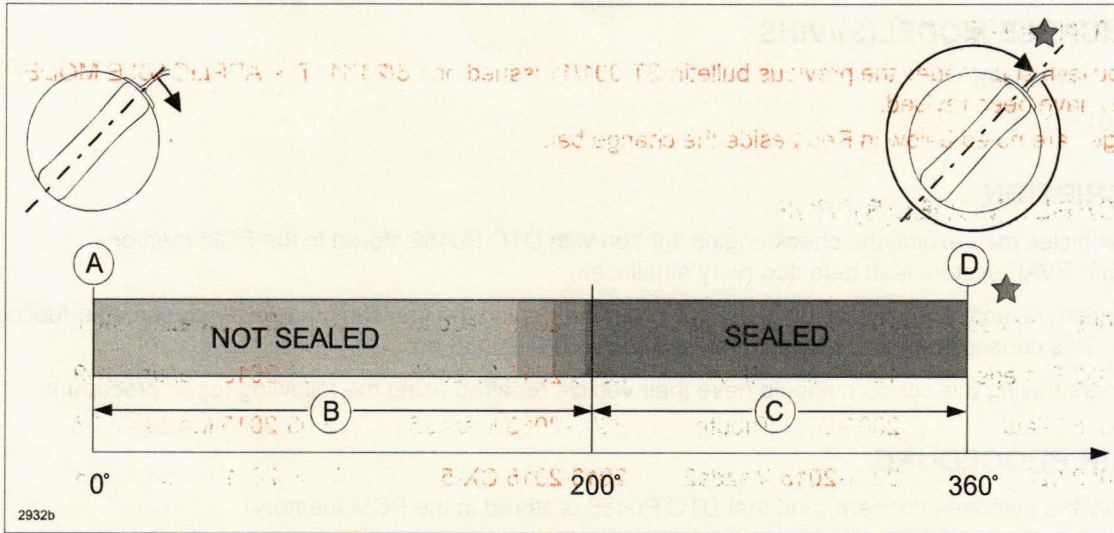

**NOTE:** The fuel cap may stay within the (C) range, since it is a large range. A leak is unlikely to occur, even if the fuel cap was not closed completely (until clicking sound is heard (D)).

Range	Fuel cap turning angle (degrees)		Description
	2011-13 Mazda3 and 2007-14 CX-9	2014-15 Mazda3, 2013-15 CX-5 and 2014-15 Mazda6	
A	0	0	Start fuel cap closing.
B	0 - 80	0 - 200	Sealing is NOT complete. A small leak may occur if fuel cap closing stopped within this range.
C	80 - 90 (small range)	200 - 360 (large range)	Sealing is complete. A leak will not occur, even if fuel cap closing is stopped within this range.
D	> 90	> 360	Complete fuel cap closing (clicking sound is heard).

**WARRANTY INFORMATION**

**NOTE:** This repair is not warrantable.