

Rear Brake Strut Improvement

Service
Category Brake

Section Brake (rear)

Market USA

Toyota Supports
ASE Certification 

Applicability

YEAR(S)	MODEL(S)	ADDITIONAL INFORMATION
2009 – 2013	Corolla	WMI(s): JTD
2009 – 2011	Corolla	WMI(s): 2T1, 5YF

REVISION NOTICE

August 30, 2013 Rev1:

- Applicability has been updated to include 2009 – 2011 model year North American produced Corolla vehicles.
- Repair Procedure has been updated.

Any previous printed versions of this bulletin should be discarded.

SUPERSESSON NOTICE

The information contained in this bulletin supersedes SB No. T-SB-0189-12 .

- Applicability has been updated to include 2009 – 2013 model year Japan built Corolla vehicles.
- Repair Procedure has been updated.

Service Bulletin No. T-SB-0189-12 is Obsolete and any printed versions should be discarded. Be sure to review the entire content of this bulletin before proceeding.

Introduction

Some 2009 – 2013 Corolla vehicles may exhibit a condition where, over time, there is a slight, but perceptible increase in brake pedal travel. This condition has no effect on braking performance. Improved rear drum brake adjusters have been developed to address this condition.

Rear Brake Strut Improvement

Production Change Information

This bulletin applies to:

- 2009 – 2013 Japan built Corolla vehicles produced **BEFORE** the Production Change Effective VIN shown below.

MODEL	PLANT	PRODUCTION CHANGE EFFECTIVE VIN
Corolla	All CBU	JTDBU4EE#DJ109475

- 2009 – 2011 North American built Corolla vehicles produced **BEFORE** the Production Change Effective VINs shown below.

MODEL	PLANT	PRODUCTION CHANGE EFFECTIVE VIN
Corolla	TMMC	2TIBU4EE#BC707539
	TMMMS	5YFBU4EE#BP001039

Warranty Information

OP CODE	DESCRIPTION	TIME	OFF	T1	T2
BR1204	R & R Drum Brake Strut Kit	1.4	04943-02070 04943-52030	4B	41

APPLICABLE WARRANTY

- This repair is covered under the Toyota Comprehensive Warranty. This warranty is in effect for 36 months or 36,000 miles, whichever occurs first, from the vehicle's in-service date.
- Warranty application is limited to occurrence of the specified condition described in this bulletin.

Parts Information

PART NUMBER		PART NAME	QTY
PREVIOUS	NEW		
04943-52030 04943-02070	04943-12040 04943-02080	Strut Kit, Rear Drum Brake	1

Rear Brake Strut Improvement

Required Tools & Equipment

SPECIAL SERVICE TOOLS (SST)	PART NUMBER	QTY
Shoe Hold Down Spring Driver	09718-00010	1
Spring Tension Tool	09921-00010	1
Plastic Pry Tool Set*	00002-06020-01	1

* Essential SST.

NOTE
 Additional SSTs may be ordered by calling 1-800-933-8335.

Repair Procedure

1. Test drive the vehicle and confirm the condition.
2. Remove the rear wheels.
3. Remove the rear brake drums.
 - A. Disengage the parking brake.
 - B. Remove the rear drum.

NOTE
 If the rear drum cannot be removed easily, complete steps 4 and 5, otherwise, continue to step 6.

4. Remove the shoe adjusting hole plug and insert a screwdriver through the hole into the backing plate, and hold the automatic adjust lever away from the adjuster.

Figure 1.

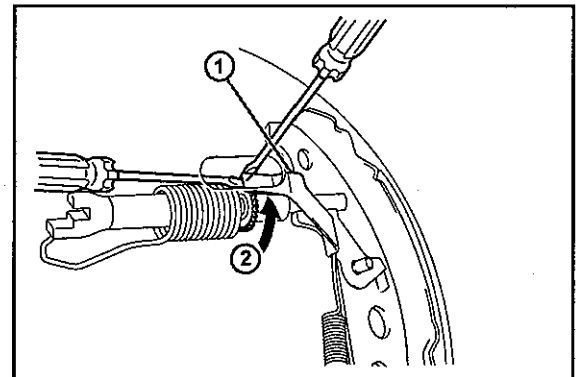

1	Automatic Adjust Lever
2	Compress

5. Using another screwdriver, compress the brake shoe by turning the adjusting bolt.

Rear Brake Strut Improvement

Repair Procedure (Continued)

6. Remove the brake shoe (forward leading).

A. Using the SST, separate the shoe return spring from the rear brake shoe.

SST: 09921-00010

NOTICE

Be cautious NOT to damage the wheel cylinder boot with the SST or the return spring during this process.

Figure 2.

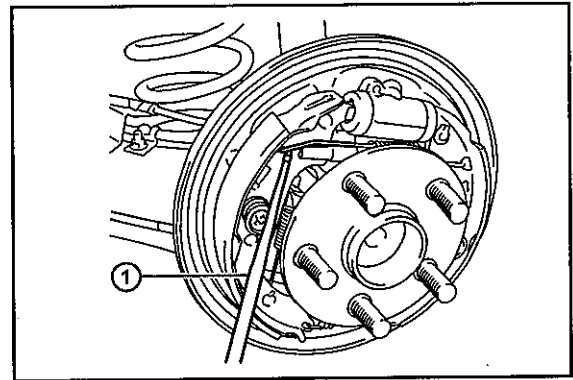

1 SST

B. Using the SST, remove the 2 shoe hold down spring cups, shoe hold down spring, pin, and the rear brake shoe.

SST: 09718-00010

Figure 3.

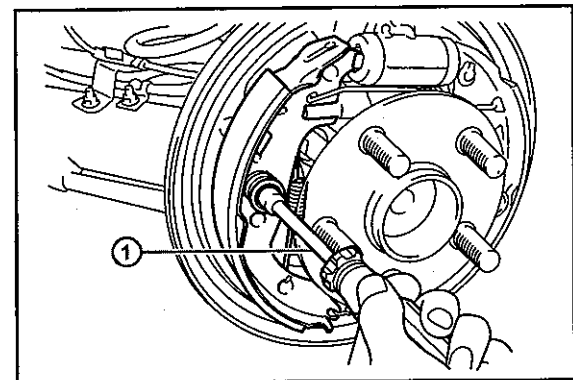

1 SST

Rear Brake Strut Improvement

Repair Procedure (Continued)

- C. Remove the tension spring to the front brake shoe and rear brake shoe.

Figure 4.

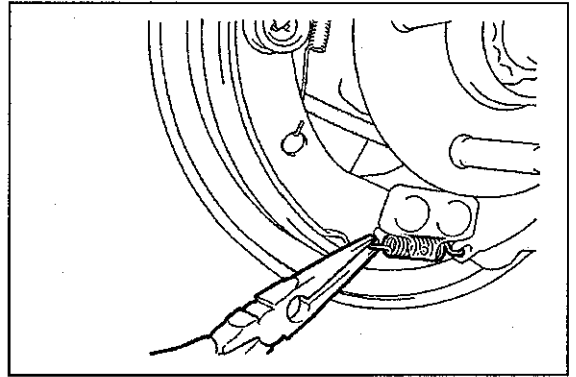

- 7. Remove the rear brake strut set.

- A. Remove the shoe return spring from the rear brake shoe and remove the rear brake shoe strut set.

Figure 5.

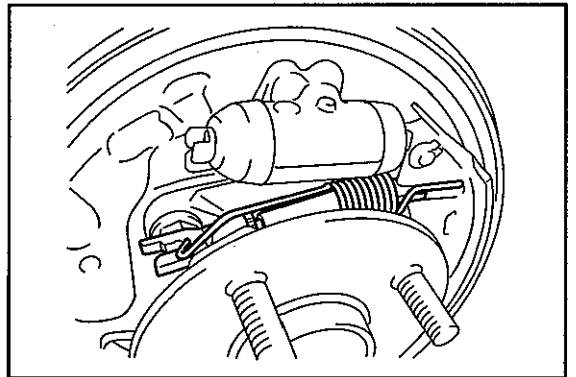

- B. Using needle-nose pliers, separate the parking brake cable.

Figure 6.

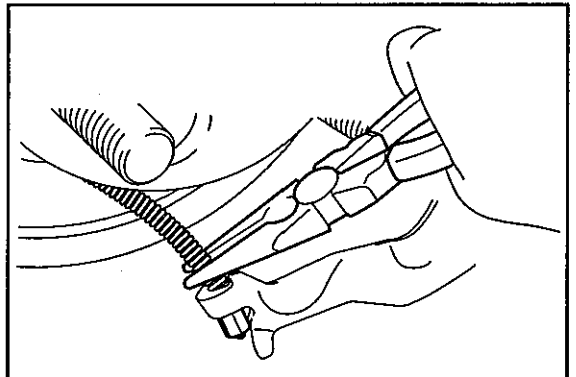

Rear Brake Strut Improvement

Repair Procedure (Continued)

8. Remove the forward leading rear brake shoes from the backing plate.

NOTE

Since the old brake shoes are being reused, there is no need to remove the parking brake lever from the brake shoe.

Figure 7.

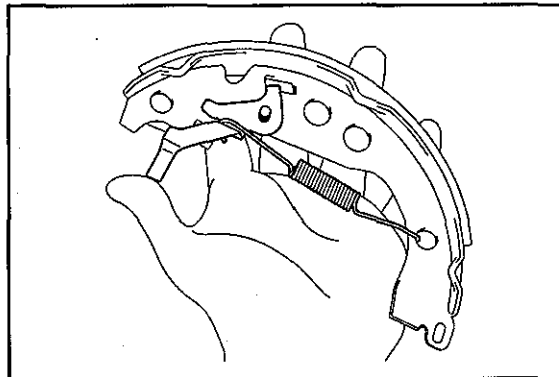

9. Install the rear brake shoes with the NEW strut set.

- A. Apply high temperature grease to the surface of the backing plate that contacts the forward leading brake shoe as indicated.

Figure 8. High Temperature Grease Locations

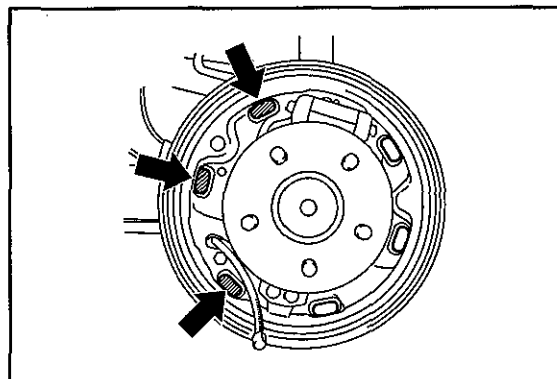

- B. Using needle-nose pliers, install the parking brake cable to the rear brake parking brake shoe lever assembly.

Figure 9.

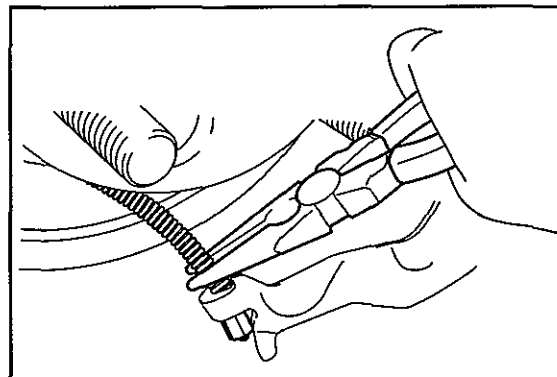

Rear Brake Strut Improvement

Repair Procedure (Continued)

- C. Using the SST, install the rear brake shoe, pin, and hold down spring cup.

SST: 09718-00010

Figure 10.

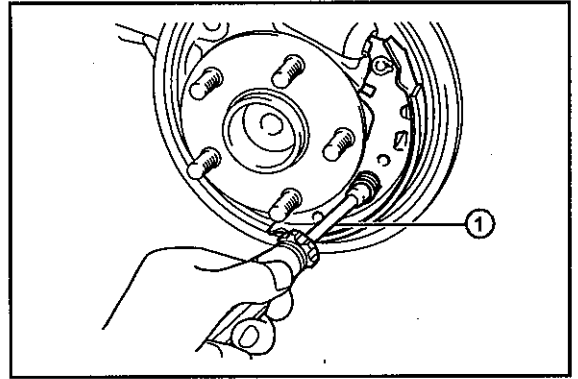

1	SST
---	-----

- D. Apply high temperature grease to the NEW adjustment bolt (strut set).

Figure 11.

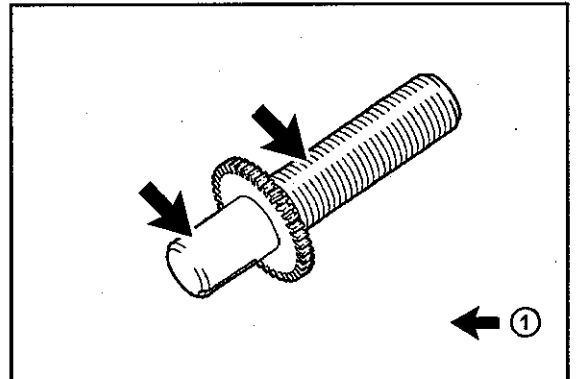

1	High Temperature Grease
---	-------------------------

Rear Brake Strut Improvement

Repair Procedure (Continued)

- E. Install the rear brake strut set assembly with tension spring.

Figure 12.

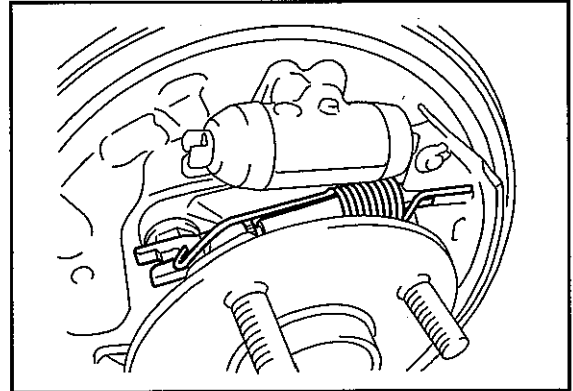

- 10. Install the rear brake shoe (forward leading).

- A. Using the SST, install the rear brake shoe, pin, hold down spring, and shoe hold down spring cup.

SST: 09921-00010

Figure 13.

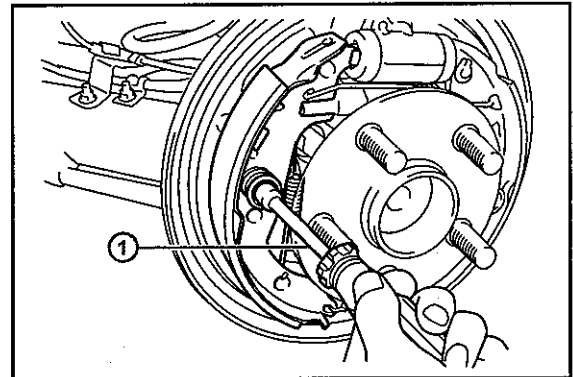

1	SST
---	-----

Rear Brake Strut Improvement

Repair Procedure (Continued)

- B. Using needle-nose pliers, install the tension spring to the rear brake shoe.

Figure 14.

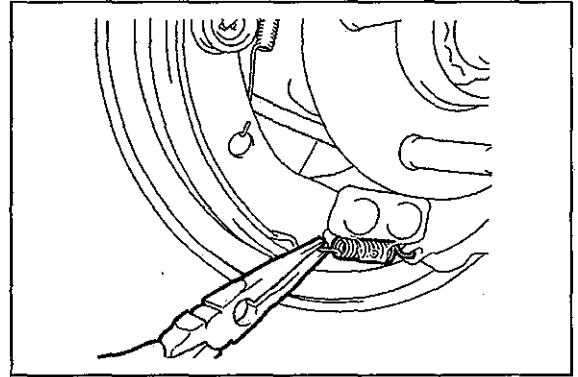

- C. Using the SST, install the shoe return spring to the rear brake shoe.

SST: 09921-00010

Figure 15.

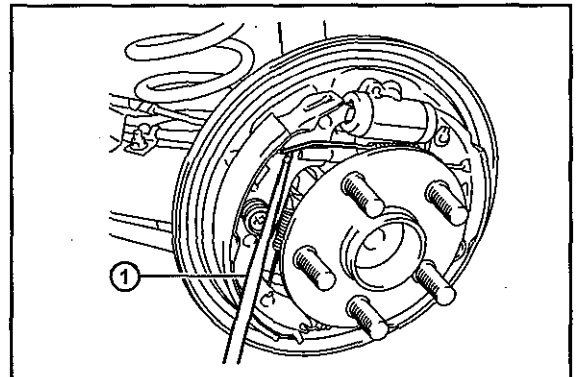

NOTICE

Be cautious NOT to damage the wheel cylinder boot with the SST or the return spring during this process.

1	SST
---	-----

Rear Brake Strut Improvement

Repair Procedure (Continued)

11. Inspect the rear brake drum.

A. Inspect that each part is installed properly as shown in the illustration.

Figure 16.

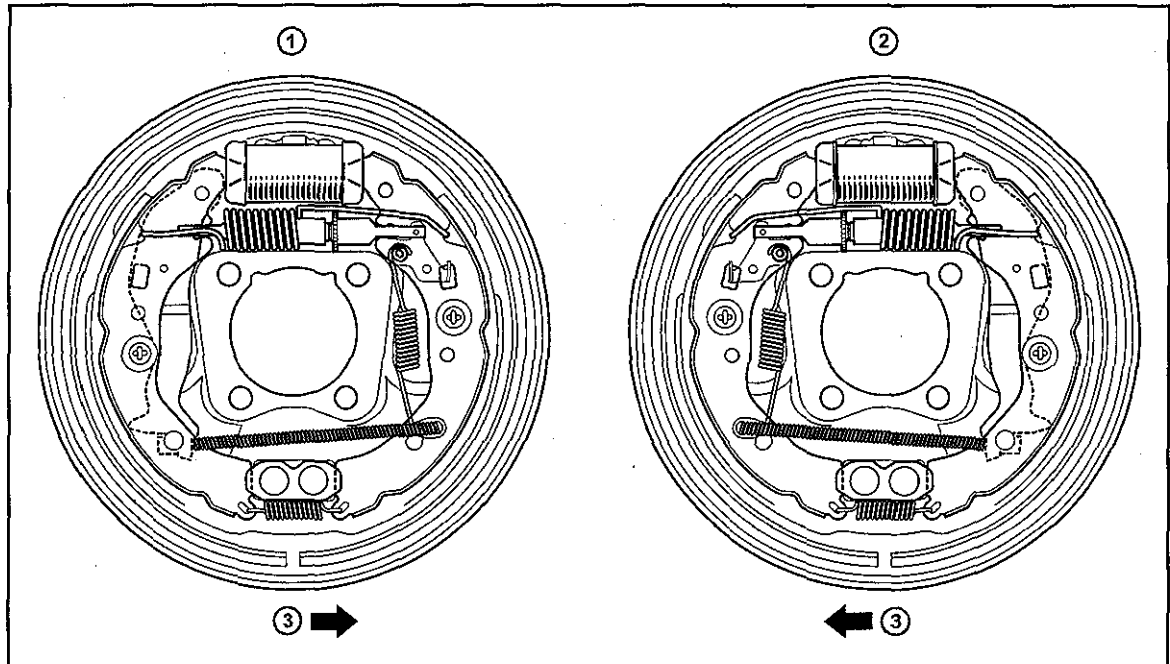

1	RH Side
2	LH Side

3	Front
---	-------

NOTICE
There should be NO oil or grease on the shoes or drum.

Rear Brake Strut Improvement

Repair Procedure (Continued)

- B. Measure the brake drum inner diameter and the diameter of the brake shoes. Check that the difference between the diameters is equal to the specified shoe clearance.

Shoe Clearance: 0.4 mm (0.0157 in.)

Figure 17.

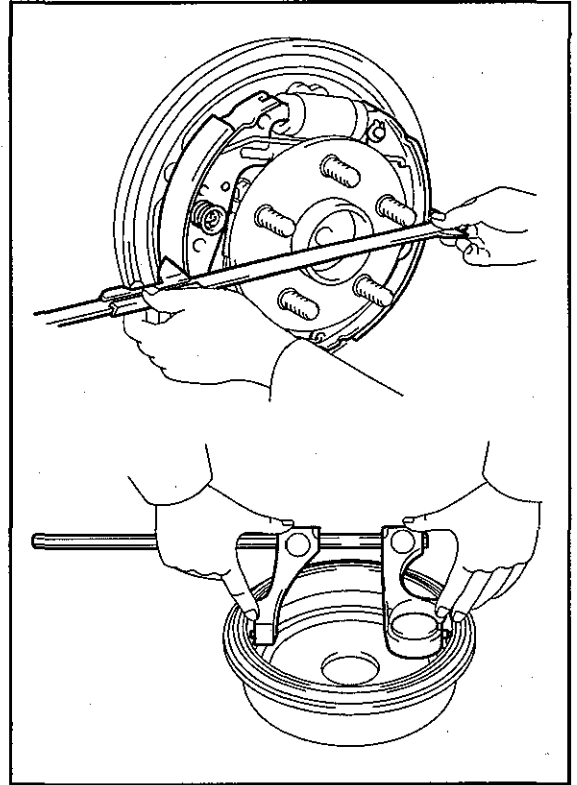

- C. Install the rear brake drum(s).

Rear Brake Strut Improvement

Repair Procedure (Continued)

12. Adjust parking brake lever travel.

A. Remove the upper console box assembly.

Using a plastic pry tool, disengage the 6 clips and 2 guides, and remove the upper console panel sub-assembly.

Figure 18.

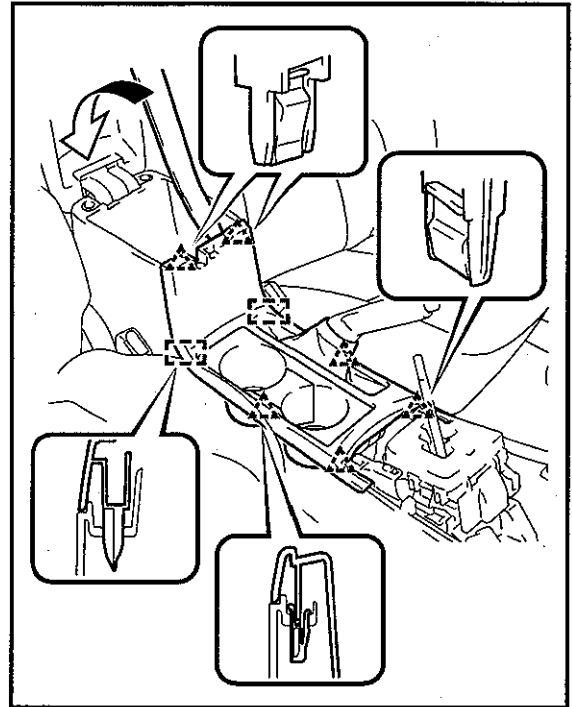

B. Completely release the parking brake lever.

Rear Brake Strut Improvement

Repair Procedure (Continued)

- C. Loosen the lock nut and the adjusting nut to completely release the cable.

Figure 19.

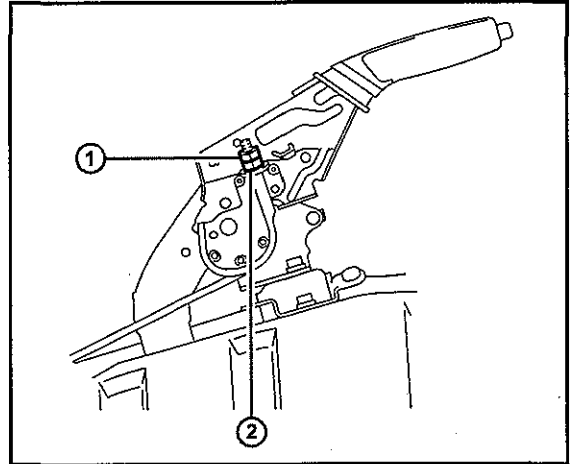

1	Lock Nut
2	Adjusting Nut

- D. Operate the brake lever 3 to 5 times with the engine stopped.
- E. Turn the adjusting nut until the parking brake lever travel is corrected to within the specified range.
Parking Brake Lever Travel: 6 to 9 notches at 200 N*m (2040 kgf*cm, 147 ft*lbf)
- F. Using a wrench or an equivalent tool, hold the adjusting nut and tighten the lock nut.
Torque: 6 N*m (61 kgf*cm, 53 in*lbf)
- G. Operate the parking brake lever 3 to 4 times, and check the parking brake lever travel.
- H. Check for any rear brake drag and adjust as needed.

Rear Brake Strut Improvement

Repair Procedure (Continued)

- I. Install the upper console box assembly by engaging the 6 clips and 2 guides.

Figure 20.

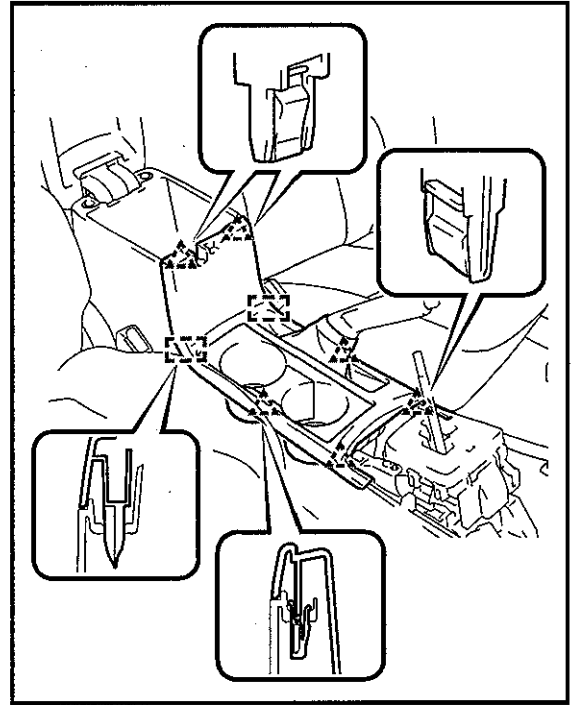

13. Install the rear wheels and torque to specification.

Torque: 103 N*m (1050 kgf*cm, 76 ft*lb)

14. Test drive the vehicle and confirm proper brake operation and pedal feel.