

NUMBER: 02-005-14

GROUP: Front Suspension

DATE: June 21, 2014

This bulletin is supplied as technical information only and is not an authorization for repair. No part of this publication may be reproduced, stored in a retrieval system, or transmitted, in any form or by any means, electronic, mechanical, photocopying, or otherwise, without written permission of Chrysler Group LLC.

SUBJECT:

Rattle Noise Heard From Front End Or Front Suspension

OVERVIEW:

This bulletin involves verifying the customer's symptom/condition and if necessary, replacing front struts.

MODELS:

2011 - 2014 MK Compass/Patriot

NOTE: This bulletin applies to vehicles built on or after September 19, 2010 (MDH 0919XX) and on or before February 12, 2014 (MDH 0212XX).

SYMPTOM/CONDITION:

Rattle noise heard from the front strut of vehicle while driving over bumps on rough roads.

DIAGNOSIS:

If the customer describes the symptom, perform the Repair Procedure.

PARTS REQUIRED:

Qty.	Part No.	Description
1 (AR)	05168164AD	STRUT, Front (RH) Patriot 4x4: with Touring Suspension (Sales Code SDC) Compass: with Touring Suspension (Sales Code SDC) and Freedom-Drive II Off-Road Group (Sales Code AWL)
1 (AR)	05168165AD	STRUT, Front (LH) Patriot 4x4: with Touring Suspension (Sales Code SDC) Compass: with Touring Suspension (Sales Code SDC) and Freedom-Drive II Off-Road Group (Sales Code AWL)
1 (AR)	05168218AD	STRUT, Front (RH) Patriot 4x2 with Touring Suspension (Sales Code SDC) Compass: with Touring Suspension (Sales

Qty.	Part No.	Description
		Code SDC) and without Freedom-Drive II Off-Road Group (Sales Code AWL)
1 (AR)	05168219AD	STRUT, Front (LH) Patriot 4x2 with Touring Suspension (Sales Code SDC) Compass: with Touring Suspension (Sales Code SDC) and without Freedom-Drive II Off-Road Group (Sales Code AWL)
1 (AR)	05168166AD	STRUT, Front (RH) With Euro Suspension (Sales Code SDF) (International)
1 (AR)	05168167AD	STRUT, Front (LH) With Euro Suspension (Sales Code SDF) (International)

REPAIR PROCEDURE:

1. For diagnostic purposes, test drive the vehicle over bumps on rough roads while listening for rattle noise coming from the front strut(s). Was a rattle noise coming from the front strut(s)?
 - a. Yes>>> Continue with Step #2.
 - b. No>>> STOP: Further diagnosis is required, this bulletin does not apply.
2. With the vehicle on the ground, grasp the top of the tire and check for lateral movement inboard and outboard at the top of tire (Fig. 1). Was lateral movement of approximately 5 mm - 10 mm (3/16 in. - 3/8 in.) detected at top of tire?
 - a. Yes>>> Continue with Step #3.
 - b. No>>> STOP: Further diagnosis is required, this bulletin does not apply.

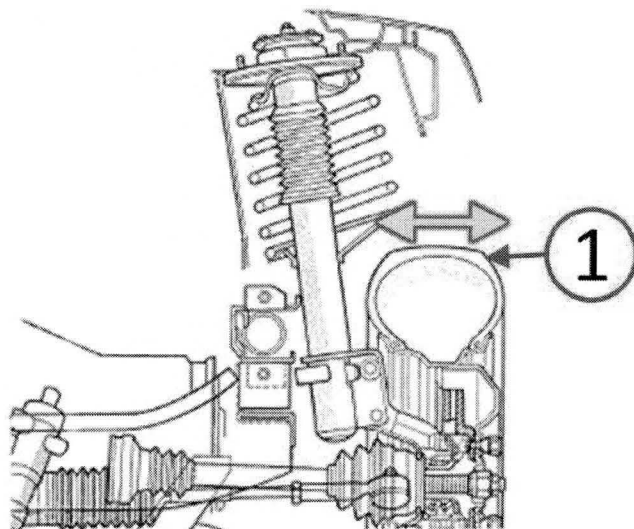
**Fig. 1 Test For Lateral Movement**

NOTE: Be sure to review all warnings and cautions before proceeding, refer to the detailed information available in DealerCONNECT> TechCONNECT under: Service Info> 02 - Front Suspension> Front> Warning.

3. Remove the front strut assemblies from the vehicle. Refer to the detailed repair procedures available in: DealerCONNECT> TechCONNECT under: Service Info> 02 - Front Suspension> Front> STRUT, Suspension, Assembly> Removal.
4. Disassemble the front struts. Refer to the detailed repair procedures available in: DealerCONNECT> TechCONNECT under: Service Info> 02 - Front Suspension> Front> STRUT, Suspension, Assembly> Disassembly.
5. Shake both front struts while listening for rattling fragments inside. Was an internal rattling noise heard in either strut?
 - a. Yes>>> Strut is rattling internally, proceed to Step #7.
 - b. No>>> Strut is NOT rattling internally. Further diagnosis is required to determine the cause of the suspension noise. This bulletin does not apply. Continue with Step #6.
6. Are the front struts leaking, have external visible damage, or reduced function?
 - a. Yes>>> Leaks, visible damage, or reduced function is observed. It is NOT necessary to replace both struts. Replace ONLY the leaking/damaged front strut(s) with original equipment strut(s) specified for the vehicle application in Star Parts, then proceed to Step #9.
 - b. No>>> Front struts are normal and functional, no sign of leaks, visible damage, or reduced function is observed. This bulletin does not apply. Proceed to Step #9 to reassemble the front struts.
7. Is the vehicle equipped with International Sales Codes SDF?
 - a. Yes>>> Replace both front struts with 05168166AD (RH), 05168167AD (LH). Proceed to Step #9.
 - b. No>>> Continue with Step #8.
8. Replace both front struts with the proper struts specified for the vehicle application from the following list, then continue with Step #9.

COMPASS:

 - Sales Code SDC with AWL use struts 05168164AD (RH), 05168165AD (LH)
 - Sales Code SDC without AWL use struts 05168218AD (RH), 05168219AD (LH)

PATRIOT:

 - 4x4 use struts 05168164AD (RH), 05168165AD (LH)
 - 4x2 use struts 05168218AD (RH), 05168219AD (LH)

NOTE: Front struts must be replaced in matched sets as specified above. Do not mix struts from different applications.

NOTE: Be sure to review all warnings and cautions before proceeding, refer to the detailed information available in DealerCONNECT> TechCONNECT under: Service Info> 20 - Front Suspension> Warning.

9. Assemble the front struts. Refer to the detailed repair procedures available in: DealerCONNECT> TechCONNECT under: Service Info> 02 - Front Suspension> Front> STRUT, Suspension, Assembly> Assembly.
10. Install the front strut assemblies to the vehicle. Refer to the detailed repair procedures available in: DealerCONNECT> TechCONNECT under: Service Info> 02 - Front Suspension> Front> STRUT, Suspension, Assembly> Installation.

11. Align the vehicle. Refer to the detailed repair procedures available in:
 DealerCONNECT> TechCONNECT under: Service Info> 02 - Front Suspension>
 Wheel Alignment> Standard Procedure.

POLICY:

Reimbursable within the provisions of the warranty.

TIME ALLOWANCE:

Labor Operation No:	Description	Skill Category	Amount
02-05-33-98	Road Test Diagnosis (2 - Skilled)	4 - Chassis Systems	0.2 Hrs.
02-05-33-99	Road Test And Check Lateral Movement Diagnosis (2 - Skilled)	4 - Chassis Systems	0.3 Hrs.
02-05-33-9A	Disassembly Diagnosis And Reassembly/Replacement Of Front Struts Plus Front Alignment (2 - Skilled)	4 - Chassis Systems	1.9 Hrs.

FAILURE CODE:

ZZ	Service Action
----	----------------