



Recall Bulletin



PRODUCT SAFETY RECALL

SUBJECT: Ignition Switch Replacement

MODELS: 2005-2007 Chevrolet Cobalt
2005-2006 Pontiac Pursuit (Canada Only)
2007 Pontiac G5

The Parts Information and Warranty Transaction Information sections have been revised. Please discard all copies of bulletin 13454A.

Vehicles involved in this safety recall are also involved in safety recall 14113 or 14133. Check the Investigate Vehicle History (IVH) screen in the GM Global Warranty Management (GWM) system to determine which additional field action is applicable. Perform the service procedure provided in that bulletin in conjunction with the repair described in this bulletin.

In the interest of customer satisfaction and to assist with dealer throughput, recall repairs for 13454 and 14113 or 14133 should be performed in a single visit. Customers will receive a notification letter in the near future advising them that parts are becoming available for recalls 13454 and 14113 or 14133, and they should contact their dealer to arrange a service appointment for the recall repairs. When contacted for a service appointment, schedule their appointment as soon as possible based on parts availability. Please place orders only for the ignition switch part number 23215459 and include the VIN. Orders will be fulfilled with parts needed for both recalls based on this.

CONDITION

General Motors has decided that a defect which relates to motor vehicle safety exists in 2005-2007 model year (MY) Chevrolet Cobalt, 2005-2006 MY Pontiac Pursuit, and 2007 MY Pontiac G5 vehicles. There is a risk, under certain conditions, that the ignition switch may move out of the "run" position, resulting in a partial loss of electrical power and turning off the engine. This risk increases if the key ring is carrying added weight (such as more keys or the key fob) or the vehicle experiences rough road conditions or other jarring or impact related events. If the ignition switch is not in the run position, the air bags may not deploy if the vehicle is involved in a crash, increasing the risk of injury or fatality.

Whenever a customer contacts you about the recalls it is imperative that you remind them of the following:

Until the recall repairs have been performed, it is very important that you remove all items from your key ring, leaving only the vehicle key. The key fob (if applicable), should also be removed from your key ring. Also, when exiting your vehicle, always make sure your vehicle is in “Park”, or in the case of a manual transmission, put the transmission into reverse gear. Always set the parking brake.

After the repairs, only use the new round hole keys and rings that have been provided to you by your dealer. Destroy any old slotted keys you still have that have not been turned into your GM dealer. Your GM dealer will provide replacement keys for your vehicle free of charge for the life of the vehicle. If you obtain an ignition key elsewhere, always use a key of the exact same design as the repair key, including the shape, and size, and with only a round key hole.

CORRECTION

Dealers are to replace the ignition switch.

VEHICLES INVOLVED

All involved vehicles are identified by Vehicle Identification Number on the Investigate Vehicle History screen in GM Global Warranty Management system. Dealership service personnel should always check this site to confirm vehicle involvement prior to beginning any required inspections and/or repairs. It is important to routinely use this tool to verify eligibility because not all similar vehicles may be involved regardless of description or option content.

For dealers with involved vehicles, a listing with involved vehicles containing the complete vehicle identification number, customer name, and address information has been prepared and will be provided to U.S. and Canadian dealers through the GM GlobalConnect Recall Reports. Dealers will not have a report available if they have no involved vehicles currently assigned.

The listing may contain customer names and addresses obtained from Motor Vehicle Registration Records. The use of such motor vehicle registration data for any purpose other than follow-up necessary to complete this recall is a violation of law in several states/provinces/countries. Accordingly, you are urged to limit the use of this report to the follow-up necessary to complete this recall.

PART INFORMATION

The parts required to complete this recall are to be obtained from General Motors Customer Care and Aftersales (GMCCA). Please refer to your “involved vehicles listing” before ordering.

Part Number	Description	Quantity/Vehicle
23215459	Ignition and Start Switch	1

Note: GMCCA will utilize the VIN number provided on the ignition switch order to place an order on your behalf for the parts required for this recall as well as to complete safety recall 14113 or 14133, whichever is applicable. This will ensure alignment of the ignition switch shipment with the parts needed to complete all required recalls. You will receive the parts required for the repair as a kit. The kit will contain an ignition switch, an ignition lock cylinder, two ignition keys and two key rings, or an ignition switch, two ignition keys and two key rings.

Please refer to GM GlobalConnect messages G_0000191127 and G_0000192219 for ignition switch ordering instructions and to review the Ignition Switch Reference Guide.

Note: Individual kit parts that are damaged during installation can be replaced by calling the GM Product Quality Center (PQC) at 866-654-7654. Dealers must provide the kit number. Do not call the PQC for part order rejection issues. Please contact your District Service Manager Aftersales (DMA) for assistance in resolving rejected part orders.

SERVICE PROCEDURE

CAUTION: To avoid part damage carefully read and follow the instructions below.

- Refer to the appropriate model and model year service procedure in Service Information (SI) BEFORE removing or replacing an ignition switch or key lock cylinder.
- If replacing both the ignition lock cylinder and the ignition and start switch, always replace the ignition and start switch first before removing the ignition lock cylinder, as misalignment between the ignition and start switch housing and the ignition and start switch will occur, resulting in permanent damage to the ignition and start switch.
- In order to allow the ignition and start switch to be removed or installed, always ensure the ignition lock cylinder is in the RUN position. Once the ignition and start switch is removed, do not move or turn the ignition lock cylinder during the procedure, as misalignment between the ignition and start switch housing and the ignition and start switch will occur, resulting in permanent damage to the ignition and start switch.
- Never rotate the actuator shaft on the ignition and start switch as permanent damage to the ignition and start switch will occur.
- When installing the ignition and start switch, if the switch does not freely slide into position, slightly rotate the ignition key clockwise and then counterclockwise while very lightly pressing on the ignition and start switch until it is fully seated.
- If a key learn procedure or programming event is required, use a Tech 2 or Tech 2 WIN scan tool.

Note: Vehicles involved in this safety recall are also involved in safety recall 14113 or 14133. Check the Investigate Vehicle History (IVH) screen in the GM Global Warranty Management (GWM) system to determine which additional field action is applicable. Perform the service procedure provided in that bulletin in conjunction with the repair described in this bulletin.

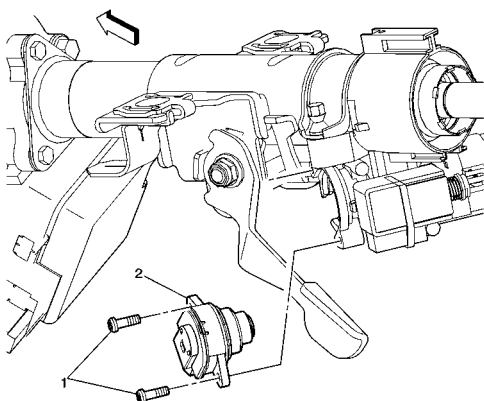

1. Remove the ignition switch from the vehicle. Refer to *Ignition and Start Switch Replacement* in SI.
2. Install a new ignition switch. Refer to *Ignition and Start Switch Replacement* in SI.

CUSTOMER REIMBURSEMENT – U.S.

Customer requests for reimbursement of previously paid repairs for the recall condition are to be submitted to the dealer by May 31, 2015, unless otherwise specified by state law. If this is not convenient for the customer, they may mail the completed Customer Reimbursement Request Form and all required documents to the GM Customer Assistance Center.

All reasonable and customary costs to correct the condition described in this bulletin should be considered for reimbursement. Any questions or concerns should be reviewed with your GM representative prior to processing the request.

When a customer requests reimbursement, they must provide the following:

- A completed Customer Reimbursement Request Form. This form is mailed to the customer or can be obtained through GM GlobalConnect.
- The name and address of the person who paid for the repair.
- Paid receipt confirming the amount of the repair expense, a description of the repair, and the person or entity performing the repair.

IMPORTANT: GM requires dealers to approve or deny a reimbursement request within 30 days of receipt. If a reimbursement request is approved, the dealer should immediately issue a check to the customer and submit an appropriate warranty transaction for the incurred expense. If a reimbursement request is denied, the dealer MUST provide the customer with a clear and concise explanation, in writing, as to why the request was denied. The bottom portion of the Customer Reimbursement Request Form may be used for this purpose. If the denial was due to missing documents, the customer can resubmit the request when the missing documents are obtained, as long as it is still within the allowed reimbursement period.

Warranty transactions for customer reimbursement of previously paid repairs are to be submitted as required by GM Global Warranty Management. Additional information can also be found in Warranty Administration Bulletin 11-00-89-004.

CUSTOMER REIMBURSEMENT - For Canada and Export

Customer requests for reimbursement of previously paid repairs to correct the condition described in this bulletin are to be submitted to the dealer prior to or by May 31, 2015.

When a customer requests reimbursement, they must provide the following:

- Proof of ownership at time of repair.
- Original paid receipt confirming the amount of unreimbursed repair expense(s) (including Service Contract deductibles), a description of the repair, and the person or entity performing the repair.

All reasonable and customary costs to correct the condition described in this bulletin should be considered for reimbursement. Any questions or concerns should be reviewed with your GM representative prior to processing the request.

COURTESY TRANSPORTATION AND VEHICLE TOWING – For U.S. and Canada

Please refer to GM GlobalConnect message G_0000190527 for courtesy transportation instructions.

For purposes of this recall, it is permissible to offer courtesy transportation to those customers who express concern about the continued use of their vehicle or who require alternate transportation while the vehicle is in for the recall repairs. The availability of courtesy transportation to such customers is very important in maintaining customer satisfaction. Dealers are to ensure that these customers understand that shuttle service or some other form of courtesy transportation is available and will be provided at no charge. Dealers should refer to the General Motors Service Policies and Procedures Manual for Courtesy Transportation guidelines. In addition, for purposes of this recall, it is permissible to provide free towing to a customer who may be concerned about operating their vehicle.

WARRANTY TRANSACTION INFORMATION

Submit a transaction using the table below. All transactions should be submitted as a ZFAT transaction type, unless noted otherwise. **Please refer to GM GlobalConnect message G_0000192219 to review the Ignition Switch Reference Guide.**

Labor Code	Description	Labor Time	Net Item
9100356	Replace Ignition & Start Switch	0.4	N/A
9100402*	Courtesy Transportation	N/A	***
9100403**	Customer Reimbursement Approved	0.2	****
9100404**	Customer Reimbursement Denied - For US Dealers Only	0.1	N/A

- * To avoid having to “H” route this transaction for approval, it must be submitted prior to the repair transaction (U.S. only).
- ** To avoid having to “H” route this transaction for approval, it must be submitted prior to the repair transaction (U.S. and Canada). Note that customer reimbursement will not close this recall.
- *** The amount identified in “Net Item” should represent the actual dollar amount for courtesy transportation.
- **** The amount identified in “Net Item” should represent the actual dollar amount reimbursed to the customer.

CUSTOMER NOTIFICATION – For U.S. and Canada

General Motors will notify customers of this recall on their vehicle.

CUSTOMER NOTIFICATION – For Export

Letters will be sent to known owners of record located within areas covered by the US National Traffic and Motor Vehicle Safety Act. For owners outside these areas, dealers should notify customers.

DEALER RECALL RESPONSIBILITY – For U.S. and Export (U.S. States, Territories, and Possessions)

It is a violation of Federal law for a dealer to deliver a new motor vehicle or any new or used item of motor vehicle equipment (including a tire) covered by this notification under a sale or lease until the defect or noncompliance is remedied.

The U.S. National Traffic and Motor Vehicle Safety Act provides that each vehicle that is subject to a recall of this type must be adequately repaired within a reasonable time after the customer has tendered it for repair. A failure to repair within sixty days after tender of a vehicle is prima facie evidence of failure to repair within a reasonable time. If the condition is not adequately repaired within a reasonable time, the customer may be entitled to an identical or reasonably equivalent vehicle at no charge or to a refund of the purchase price less a reasonable allowance for depreciation. To avoid having to provide these burdensome remedies, every effort must be made to promptly schedule an appointment with each customer and to repair their vehicle as soon as possible. In the recall notification letters, customers are told how to contact the US National Highway Traffic Safety Administration if the recall is not completed within a reasonable time.

DEALER RECALL RESPONSIBILITY – All

All unsold new vehicles in dealers' possession and subject to this recall must be held and inspected/repaired per the service procedure of this recall bulletin before customers take possession of these vehicles.

Dealers are to service all vehicles subject to this recall at no charge to customers, regardless of mileage, age of vehicle, or ownership, from this time forward.

Customers who have recently purchased vehicles sold from your vehicle inventory, and for which there is no customer information indicated on the dealer listing, are to be contacted by the dealer. Arrangements are to be made to make the required correction according to the instructions contained in this bulletin. A copy of the customer letter is provided in this bulletin for your use in contacting customers. Recall follow-up cards should not be used for this purpose, since the customer may not as yet have received the notification letter.

In summary, whenever a vehicle subject to this recall enters your vehicle inventory, or is in your dealership for service in the future, you must take the steps necessary to be sure the recall correction has been made before selling or releasing the vehicle.

