



Service Bulletin

File in Section: 08 - Body and Accessories

Bulletin No.: 09-08-66-011B

Date: January, 2013

INFORMATION

Subject: Information on Mounting Points for Pickup Box Accessories

Models: 2007-2013 Chevrolet Silverado
2007-2013 GMC Sierra

This bulletin is being revised to add the 2012-2013 model years and include Additional Keywords. Please discard Corporate Bulletin Number 09-08-66-011A (Section 08 – Body and Accessories).

The pickup box was designed for the use of add-on equipment. However there are specific mounting points that must be used along with weight restrictions. Refer to the following Chart 1 – Weight Restrictions for Pickup Box Add-Ons. Structural members have been added to provide load paths directly to the platform cross-sills and into the vehicle frame. Aftermarket accessories should take advantage of these intended load paths as detailed below in Figures 1-4.

Depending on the accessory design, it may be necessary to add some form of a spacer under the accessories at the structural hard points to take up any gap. Do not use the GM Cargo Management Option mounting points for attaching anything other than the GM Cargo Management system as referenced in Figure 5.

Chart 1 – Weight Restrictions for Pickup Box Add-Ons

Equipment	Maximum Weight
Ladder Rack and Cargo	750 lbs (340 kg)
Cross Toolbox and Cargo	400 lbs (181 kg)
Side Boxes and Cargo	250 lbs per side (113 kg per side)
The combined weight for all rail-mounted equipment should not exceed 1,000 lbs (454 kg).	

Figure 1 – Side View - Structural Members

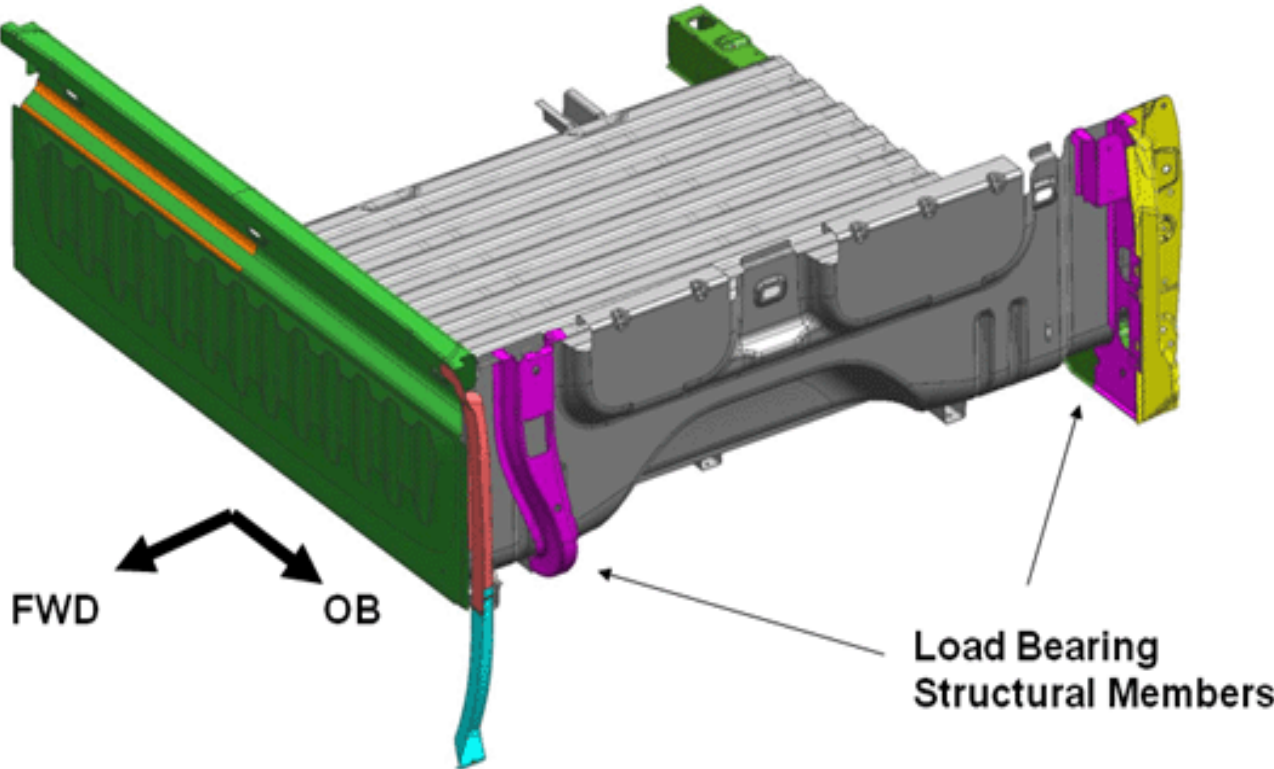

Figure 2 – Top View - Structural Members

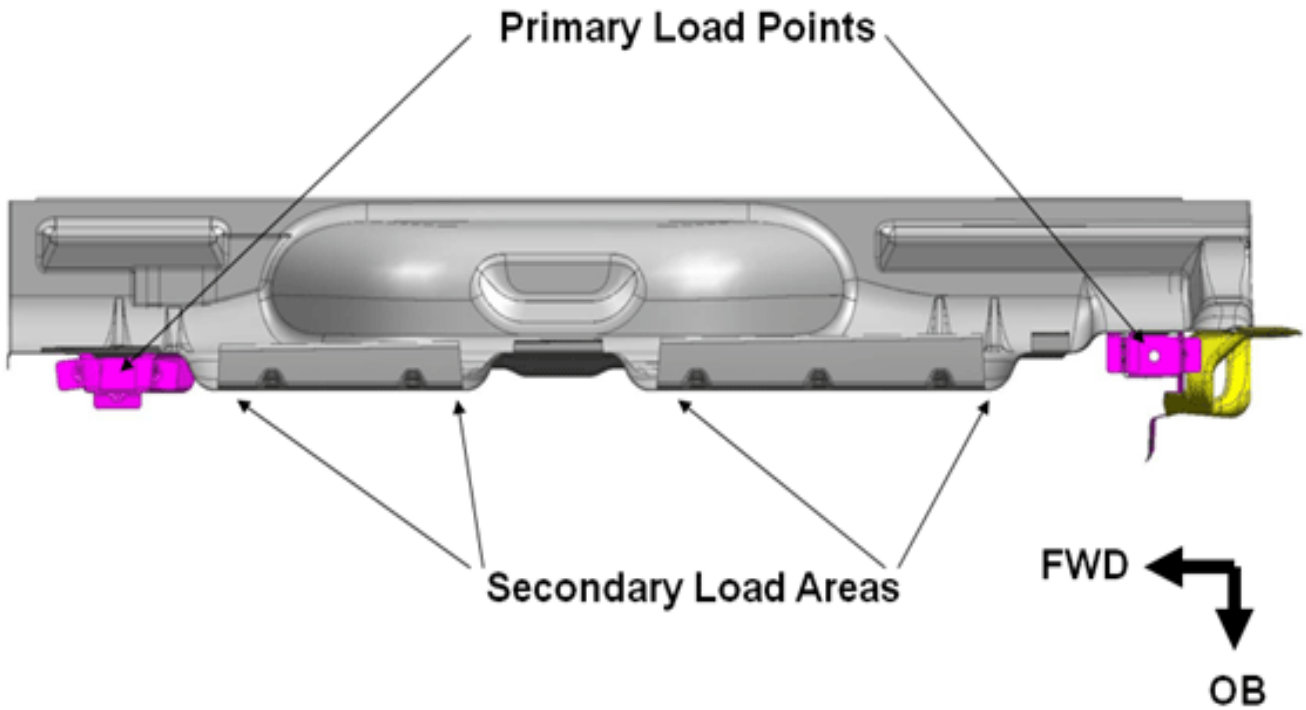

Figure 3 – Top View - Front Structure

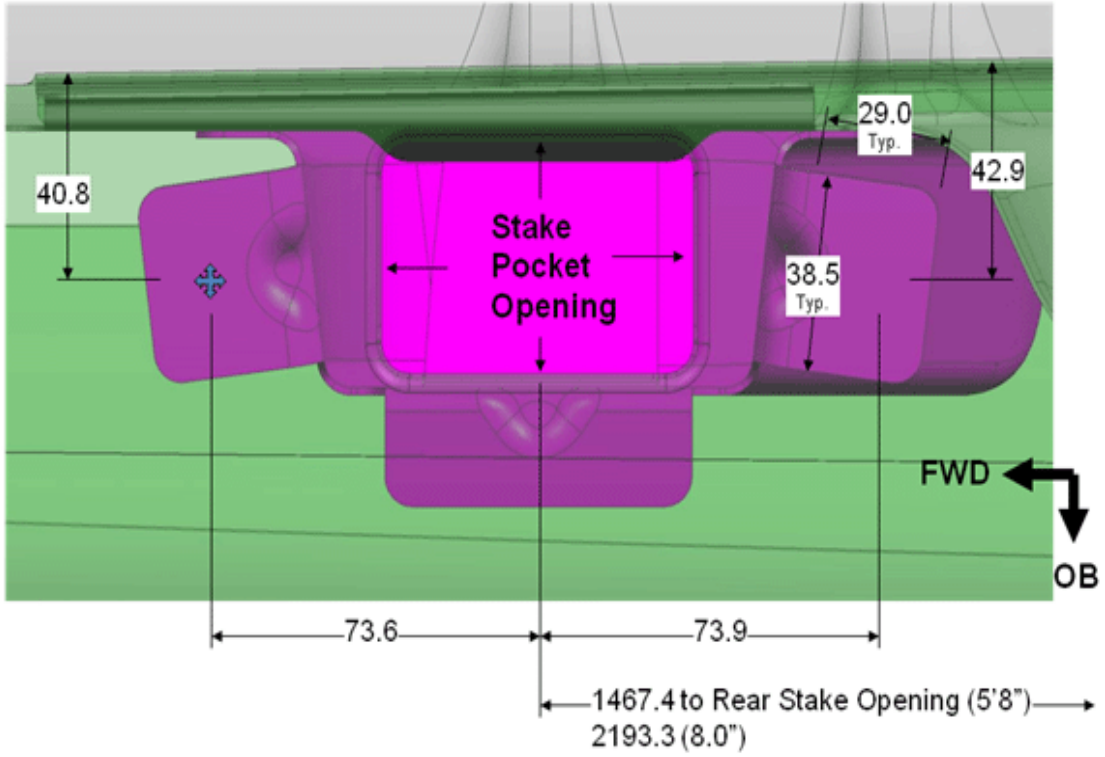

Figure 4 – Top View - Rear Structure

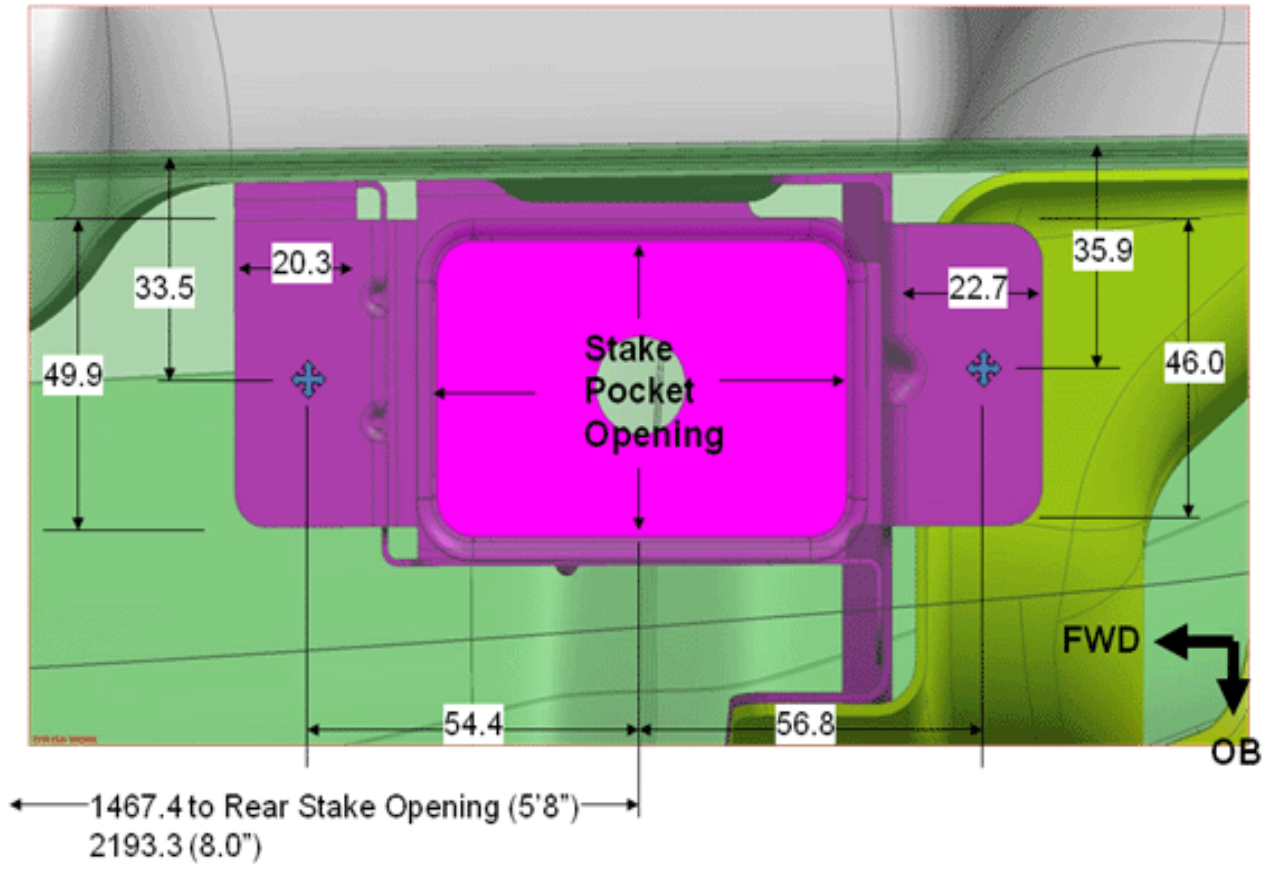
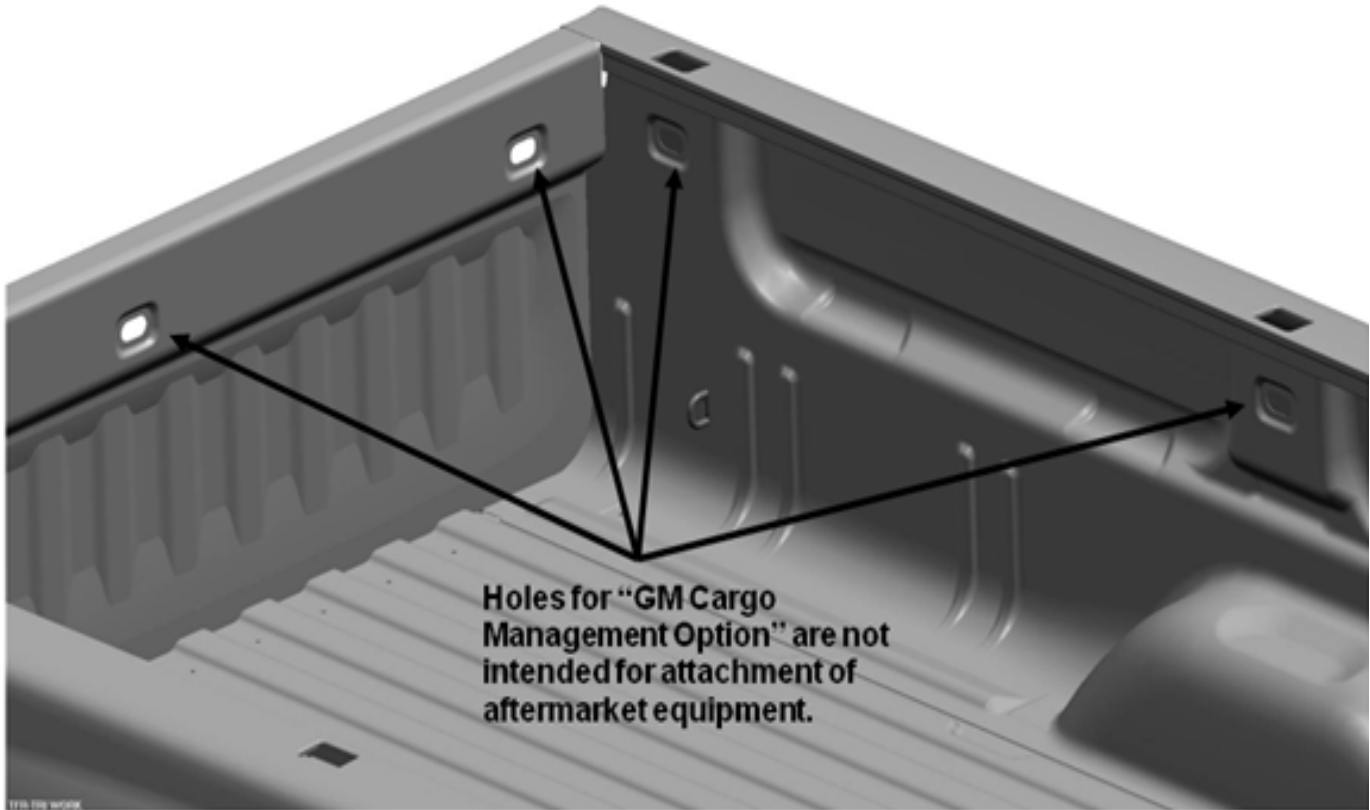

Figure 5 – GM Cargo Management Points



2371902

Caution: Overloading the vehicle may cause damage. Do not overload the vehicle. When you carry removable items, you may need to put a limit on how many people you carry inside your vehicle. Be sure to weigh your vehicle before you buy and install the new equipment. Remember not to exceed the Gross Axle Weight Rating (GAWR) of the front or rear axle.

If the vehicle is damaged due to overloading, repairs would not be covered by the vehicle warranty. The load bearing structural information is also included in the Body Builder's manual at www.gmupfitter.com.
Additional Keywords: Bed, Tool box, Equipment.