

[Initialisation of DSS1.pdf](#)

[Self Test DSS.pdf](#)

[Side Step Extra Shim Fitment.pdf](#)

Reference	SSM67677
Models	Range Rover (All New) / L405 Range Rover Sport / L494
Title	New Range Rover Sport & All New Range Rover Side Step Concerns Guide
Category	Accessories
Last modified	30-Aug-2013 00:00:00
Symptom	General Accessories
Content	<p><b>Concern</b> L405 or L494 one or more concerns with Accessory Deployable Side Steps (DSS):</p> <ol style="list-style-type: none"> <li>1. Dynamic Response Pipes contact Deployable Side Step Bracket.</li> <li>2. Free Play in Deployable Side Step Mounting Bracket</li> <li>3. Deployable Side Step Module Initialisation</li> <li>4. Deployable Side Step Fitting – Tap Hole Instruction</li> <li>5. Deployable Side Step Self-Test Procedure</li> </ol> <p><b>Action</b></p> <ol style="list-style-type: none"> <li>1. If it is noticed visually or audibly that the Dynamic Response Pipes are fouling the Side Step Bracket then please refer to TSB LTB00588</li> <li>2. If the front end of the Deployable Side Step is found to be loose when deployed, add 1 additional shim to the inner mounting point on the front of the bracket – See attached File – Side Step Extra Shim Fitment. PDF</li> <li>3. When conducting the initialisation procedure, should the Deployable Side Steps not function please see the attached file – Initialisation of DSS.PDF</li> <li>4. From Vin 120000 L405 and Vin 300000 L494, should Deployable Side Steps &amp; Tubes require fitment then all the location bosses will require tapping out. The SRO time allowance has now been included in the fitment SRO.</li> <li>5. Should a Dealer or Customer report a concern with the Deployable Side Step System operation, then at the first instance please use the DSS - ON DEMAND SELF TEST procedure within SDD to validate the system. Please see the attached file – Self Test DSS.PDF</li> </ol>

## **PRE-INITIALISATION OF DSS AFTER INSTALLATION (SWITCHING THE SYSTEM OFF/ON)**

When the DSS is first installed the electronic ECU module is delivered in an 'OFF' condition. This is designed to prevent the steps from deploying/stowing unintentionally after installation.

Before proceeding with initialisation of the DSS module, the ignition should be switched on and off to allow the vehicle network to be awake; please refer to the owners hand book for instructions.

## **INITIALISATION OF DSS 'SWITCHING THE SYSTEM OFF/ON'**

Initialisation of the DSS should be made within 60 seconds of PRE-INITIALISATION.

The DSS system is switched ON as follows;  
Ensure the ignition is OFF.  
Press and hold the DSS function switch and within 2\* seconds of holding the DSS function switch, press the START/STOP button to turn the ignition on

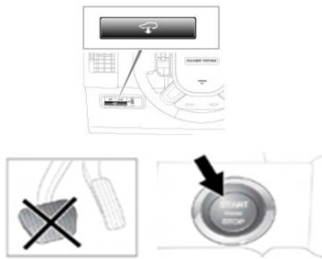

The function switch indicator will flash 3 times to indicate that the system is switched ON. To switch the system OFF, the same procedure should be followed and the function switch indicator will flash 2 times to indicate that the system is off.

\* Failure to turn the ignition ON within 2 seconds of pressing the function switch will prevent the system from switching ON/OFF

## **FUNCTION SWITCH INDICATOR DOES NOT FLASH AFTER INITIALISATION SEQUENCE**

It has been identified that the DSS initialisation process does not always switch the DSS system ON/OFF.

After performing the "SWITCHING THE SYSTEM ON/OFF" process, if the function switch indicator does not flash the process of "SWITCHING THE SYSTEM ON/OFF" should be repeated up to 10 times until the function switch indicator flashes.

If after 10 attempts the system still fails to turn ON/OFF the system should be diagnosed with dealer network tools (SDD) and any Device Trouble Codes (DTC's) should be cleared and the process from the PRE-INITIALISATION stage repeated.

## DSS ON-DEMAND SELF TEST MODE

With the DSS system fully connected in vehicle, it is possible to validate the system to determine if there are any component level faults.

To access the self mode in SDD, under Deployable Running Boards navigate to the "Recommendations" tab where "General Diagnostics and Tools" will be visible and "Diagnostic - On demand self test - Running board control module" can be selected.

This routine will deploy and stow the left and right running board. During the deploy or stowing it evaluates the relay, current feedback, hall effect circuits and will drive the status LED active. The sequence of execution is: Stow Left (only if deployed upon entry into self test), Deploy Left, Stow Left, Stow Right (only if deployed upon entry into self test), Deploy Right, Stow Right, then LED test

If the module detects a fault during the exercise of this feature it will set or reset an active DTC. If there is no active faults after the test is complete, it should reply with a system pass message

The screenshot shows the SDD interface with the following sections:

- Recommendations (Ordered by priority)**

Type	Description	Status	Options
	L405 Side Step Fitment Issues	Not read	<a href="#">Read</a>
	Deployable Side Step ECU Trouble Shooting Guide	Not available	<a href="#">Read</a>
- General Diagnostics and Tools**

Type	Description	Status	Options
	Car configuration management - Current vehicle car configuration modification	Not run	<a href="#">Run</a>
	Complete vehicle - Datalogger	Not run	<a href="#">Run</a>
	Special applications - Vehicle reset	Not run	<a href="#">Run</a>
	<b>Diagnostic - On demand self test - Running board control module</b>	Not run	<a href="#">Run</a>
	Car configuration management - Session active car configuration selection	Not run	<a href="#">Run</a> <small>click to run tool</small>
	Complete vehicle - Clear all stored diagnostic trouble codes	Not run	<a href="#">Run</a>
	Complete vehicle - Re-read all stored diagnostic trouble codes	Not run	<a href="#">Run</a>
	Complete vehicle - Re-read all stored diagnostic trouble codes including not tested codes	Not run	<a href="#">Run</a>

Footer information: Derek Kriesdemann - New Range Rover (L405) 000183 - 11 Jun 2015 16:06 (DVD134.06 v.137) The VCIM is disconnected.

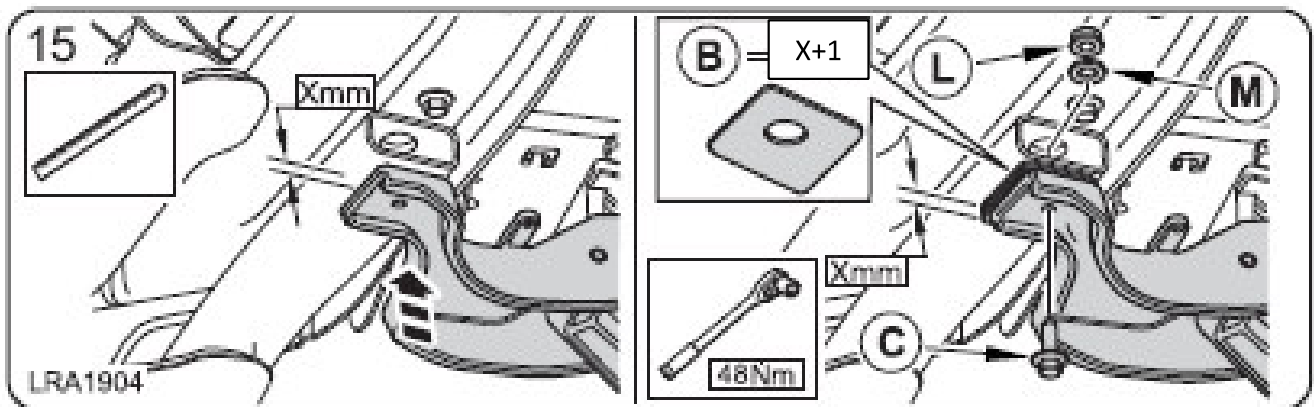
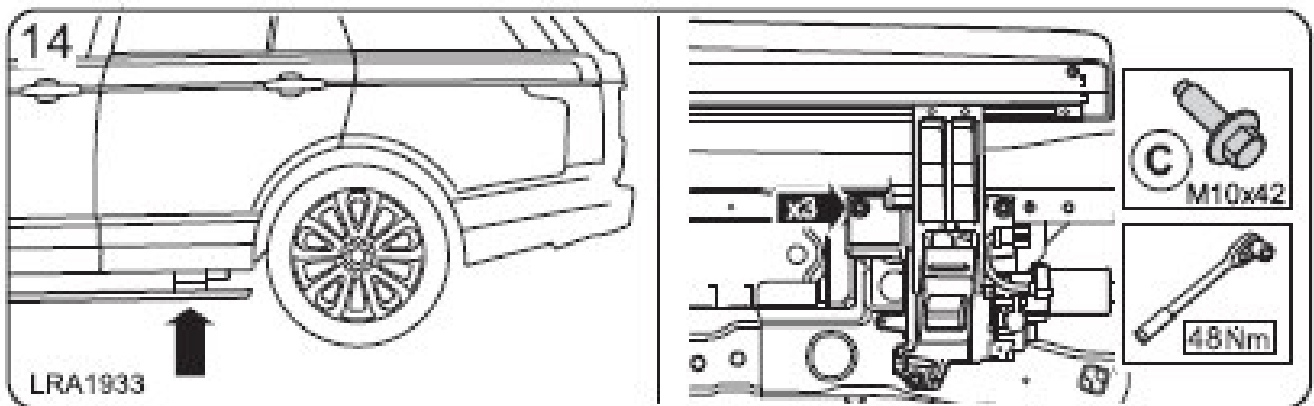
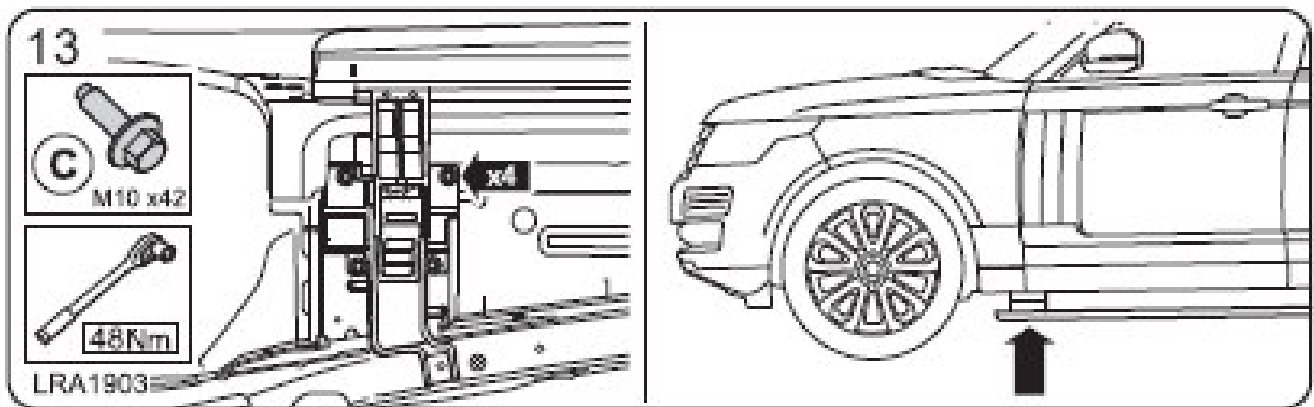
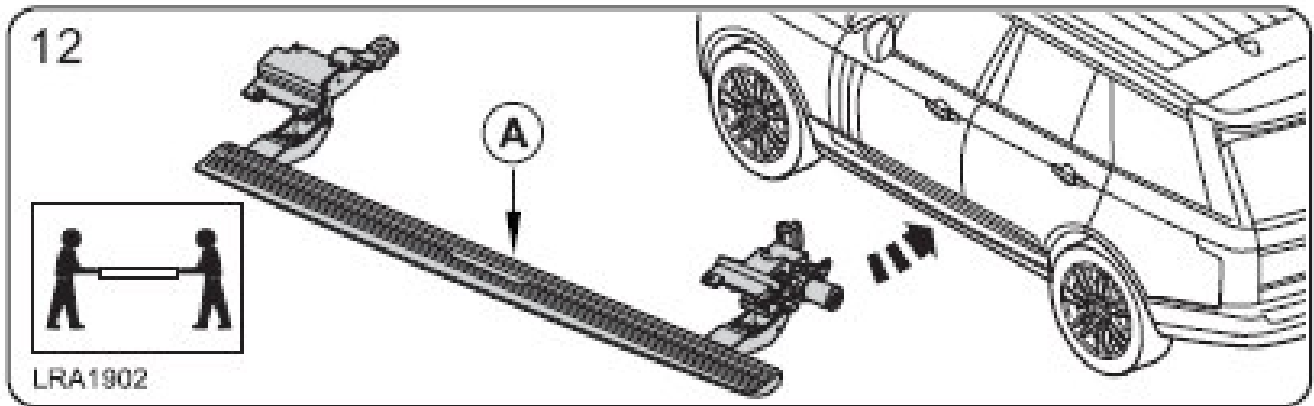

- Step front bracket appears loose due to rear bracket reaching end point before front
- Adding extra shim at front enables front link to reach end point in parallel with rear
- Gives firm fix of front bracket at end point