



Service Bulletin

File in Section: -

Bulletin No.: PIP5064A

Date: November, 2012

PRELIMINARY INFORMATION

Subject: Rough Running - Idle Surge - CEL On Or CMP Actuator Codes After Installation Of Reman HVV6

Models: 2007 Buick Rendezvous, Terraza
2007 Saturn VUE
2007 Chevrolet Monte Carlo
2007 Chevrolet Uplander
2007-2009 Chevrolet Impala, Malibu
2007-2009 Pontiac G6
2007-2008 Saturn Aura
2009 Buick Lucerne
With 3.5L Engine (RPO LZE or LZ4)
or 3.9L Engine (RPO LZ8, LZ9, LZG or LGD)

This PI was superseded to update recommended field. Please discard PIP5064.

The following diagnosis might be helpful if the vehicle exhibits the symptom(s) described in this PI.

Condition/Concern

A technician may encounter any of the following concerns after installing a Reman HVV6 engine, rough running, idle surge, misfire on one or both banks of the engine with a P0300, CEL or CMP actuator DTC P0011 and / or P0016.

Recommendation/Instructions

If you encounter the above concern, record the actual engine oil pressure.

Oil Pressure for 3.5L engines = 30–45 PSI @ 1850 RPM.

Oil Pressure for 3.9L engines = 30–45 PSI @ 1850 RPM and 26 PSI @ Idle with Warm Engine.

If oil pressure is within the specifications above, perform all testing listed in PIP4345A including a visual inspection of the camshaft position actuator filter (see picture below) and repair or replace as necessary.

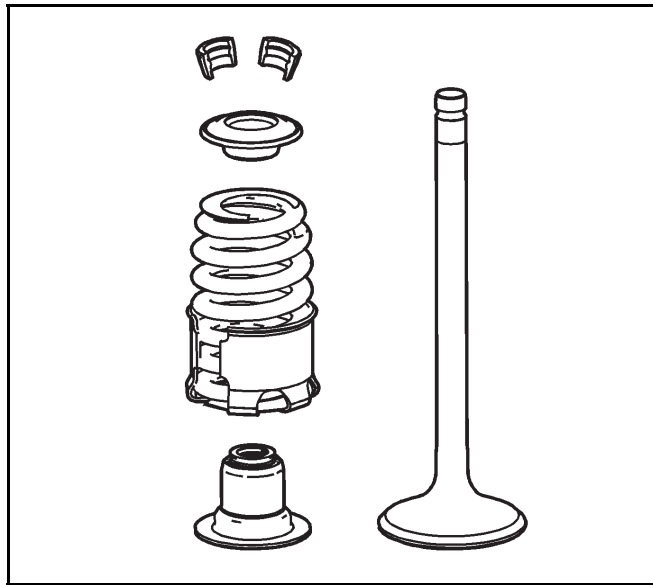

1665094

If single bank misfires are found, then remove the valve cover of the affected bank and check the valve springs for missing harmonic stabilizers. (see picture below) Replace the valve spring assemblies if the stabilizers are not present and retest for the misfires.

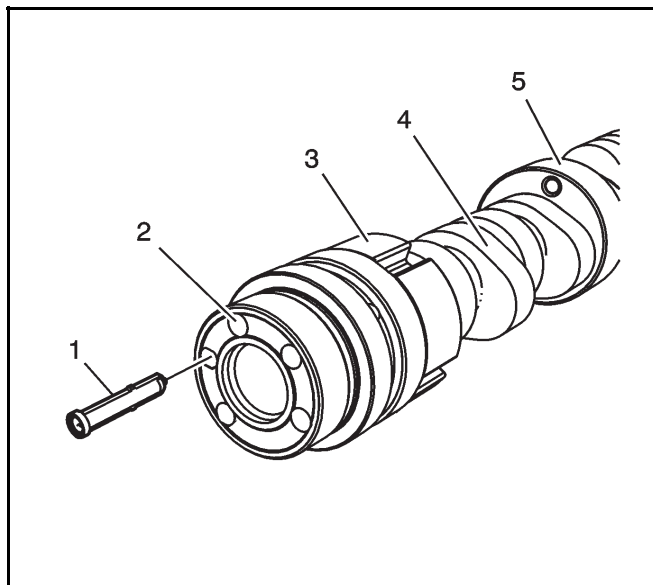

1608915

If the concern is not isolated, record the engine build date and serial number from the engine and contact TAC for additional direction.

Notice: The HVV6 identification tag location is the same for all listed engines, at the pan rail, towards the middle of the block, on the left side.

Warranty Information

The correction for this concern may be one of several repairs described above. For vehicles repaired under warranty, please use the appropriate warranty labor operation and time, based on the actual cause and repair.

Please follow this diagnostic or repair process thoroughly and complete each step. If the condition exhibited is resolved without completing every step, the remaining steps do not need to be performed.