

SAFETY RECALL

Volvo Trucks North America
Greensboro, NC USA

VOLVO

Date	Number	Release	Page
04.2016	RVXX1601	01	1 (10)

Draglink Rod, Replacement

VN, VT

SAFETY RECALL INFORMATION:

(March 2016)

VOLVO Trucks North America has determined a defect relating to motor vehicle safety may exist in certain VOLVO VN trucks manufactured between 01/06/2015 and 11/05/2015. Additionally, this defect applies to certain VOLVO VT trucks manufactured between 04/08/2008 and 11/07/2008. The draglink rod boot may be compromised and enable dirt/water to contaminate the draglink rod ball socket on some VOLVO VN trucks equipped with a sealed Uresko draglink rod. If this condition is untreated, failure of the ball socket and a complete loss of steering may be possible. Replacement of the existing draglink rod with a new greasable draglink (part number below) is necessary to prevent dirt/water contamination. The mounting hardware should be replaced with new mounting hardware each time the draglink rod is replaced. Follow the repair procedure outlined in this Safety Recall.

VOLVO Trucks considers this as a proactive measure to protect the public and VOLVO's customers from the potential risk associated with this defect.

VEHICLES AFFECTED:

Canada

Certain 2015 VOLVO VN model trucks manufactured from January 06, 2015 through November 05, 2015 and certain 2009 VOLVO VT model trucks manufactured from April 08, 2008 through November 07, 2008 with USK sealed draglink rod.

USA

Certain 2016 VOLVO VN model trucks manufactured from January 06, 2015 through November 05, 2015 and certain 2009 VOLVO VT model trucks manufactured from April 08, 2008 through November 07, 2008 with USK sealed draglink rod.

VEHICLE IDENTIFICATION NUMBERS (VIN):

The number of vehicles affected by this recall is 3,396 (2,053 USA, 503 Canada, and 840 Mexico).

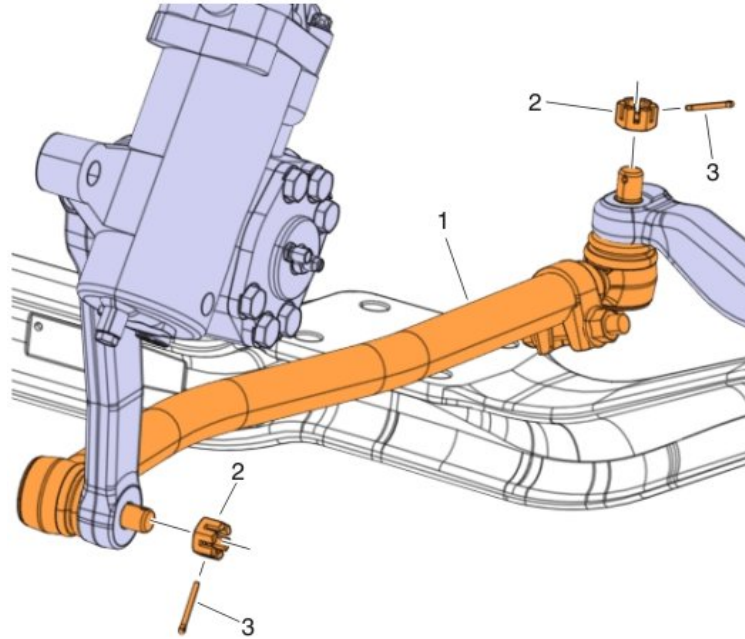

Required Parts:

To schedule parts orders and repairs, please call (877) 986-5862 with the Vehicle Identification Number (VIN) of the vehicle in need of this repair.

Failed Inspection Draglink Rod, Replacement Parts			
Item	Description	Part Number	Qty
1	Draglink Rod Assembly, VN (STG16.9B/STG18.2)	85128559	1
2	Castle Nut	10506	2
3	Split Pin	907861	2

Failed Inspection Draglink Rod, Replacement Parts			
Item	Description	Part Number	Qty
1	Draglink Rod Assembly, VN (STG21.0)	21128338	1
2	Castle Nut	10506	2
3	Split Pin	907861	2

Failed Inspection Draglink Rod, Replacement Parts			
Item	Description	Part Number	Qty
1	Draglink Rod Assembly, VT	22858515	1
2	Castle Nut	10506	2
3	Split Pin	907861	2

NOTE

The Illustrations shown in this document are used for reference only and may differ slightly from the actual vehicle being serviced. However, the replacement procedure is represented as accurately as possible.

Decommissioning the Truck for Inspection:

1. Secure the vehicle for service by parking on a flat and level surface, placing the transmission in neutral, applying the parking brake, turning the ignition key to the OFF position, and chocking the rear wheels.

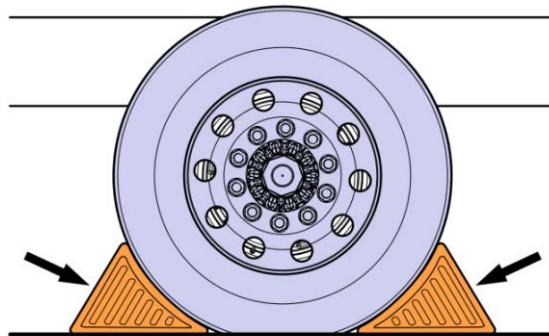

2. Disconnect the cable from the battery's negative (ground) terminal.

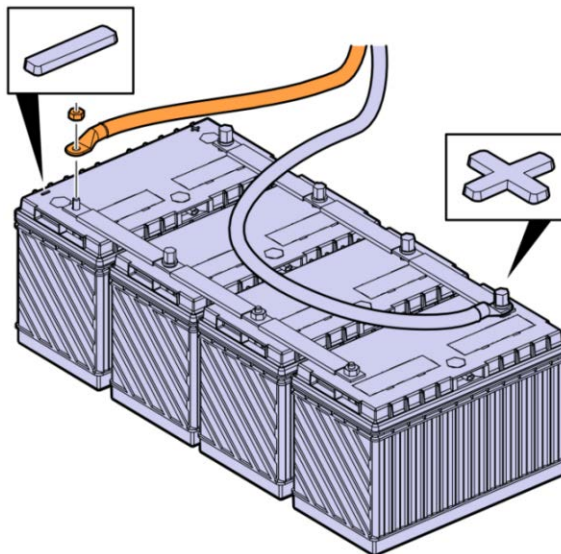

Draglink Rod, Replacement Procedure:

3. Raise the hood.
4. Remove the split pin (1) from the castle nut (2) at the steering knuckle.

5. Remove the existing castle nut.

NOTE

Discard the existing castle nut and split pin. Do not reuse.

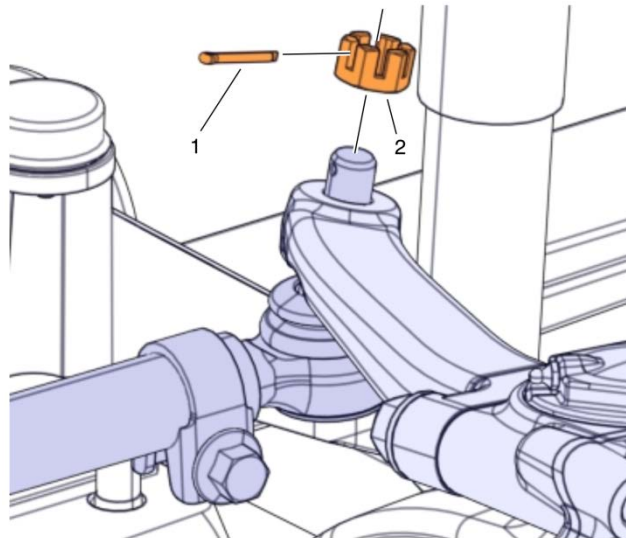

6. Using tool 9996201 (Puller), remove the existing drag link from the steering knuckle as shown in the figure below.

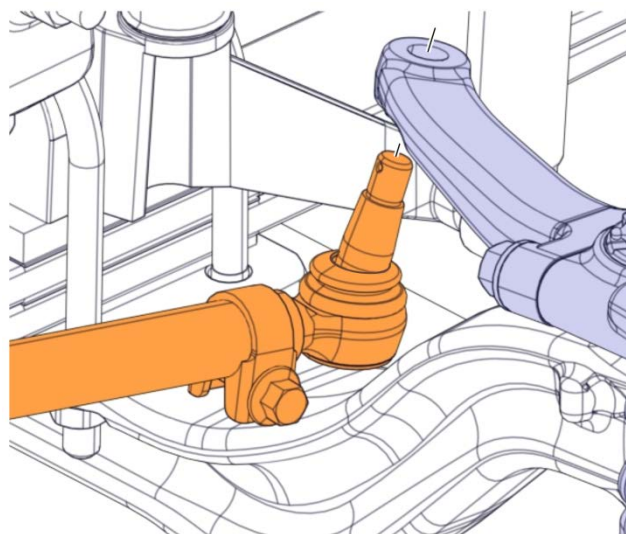

7. Remove the split pin (1) from the castle nut (2) at the pitman arm.
8. Remove the existing castle nut.

NOTE

Discard the existing castle nut and split pin. Do not reuse.

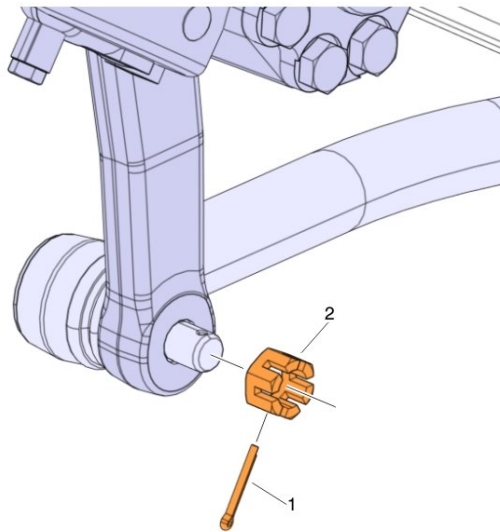

9. Using tool 9996201 (Puller), remove the existing drag link from the pitman arm as shown in the figure below.

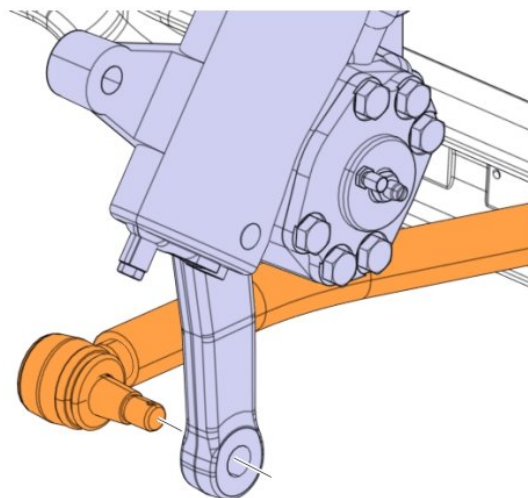

10. Adjust the replacement drag link rod to length for the correct steering wheel angle. Adjust the drag link rod to length and torque the clamp fastener as shown in the figure below.

NOTE	
Use the torque value table below for the draglink rod clamp torque specifications.	

Draglink Rod Torque Specifications	
Clamp Fastener	Torque Specification
M12 10.9	105 ± 20 Nm (77 ± 14 ft-lb)
M16 8.8	220 ± 35 Nm (162 ± 25 in-lb)

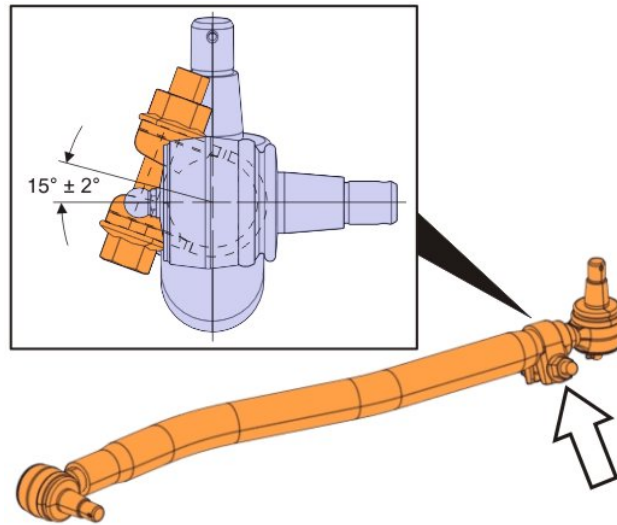

11. Position the replacement draglink rod on the pitman arm as shown in the figure below.

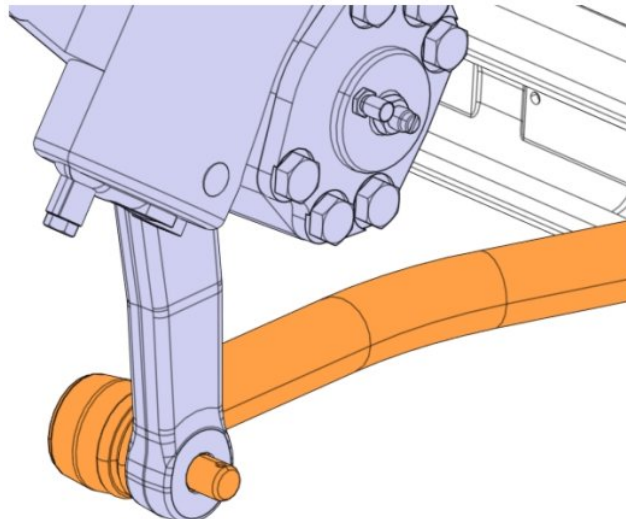

12. Install the replacement castle nut (2) (part number 10506).
13. Tighten the castle nut (part number 10506) to 200 Nm (148 ft-lb) minimum.
14. Turn the castle nut **CLOCKWISE** until the next castle nut slot aligns with the hole in the draglink rod ball socket.
15. Install the split pin (1) (part number 907861).

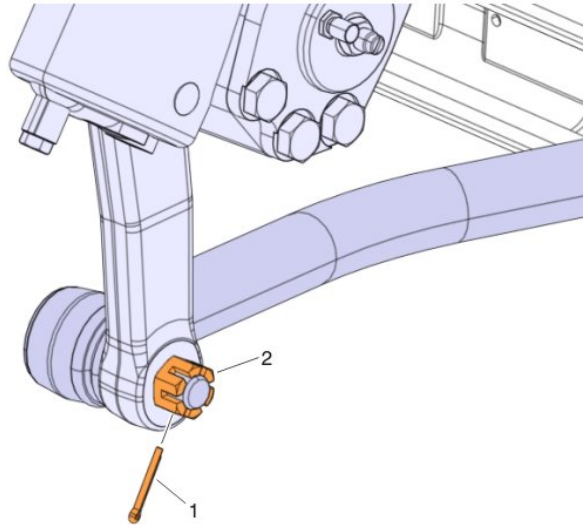

16. Position the replacement drag link rod at the steering knuckle as shown in the figure below.

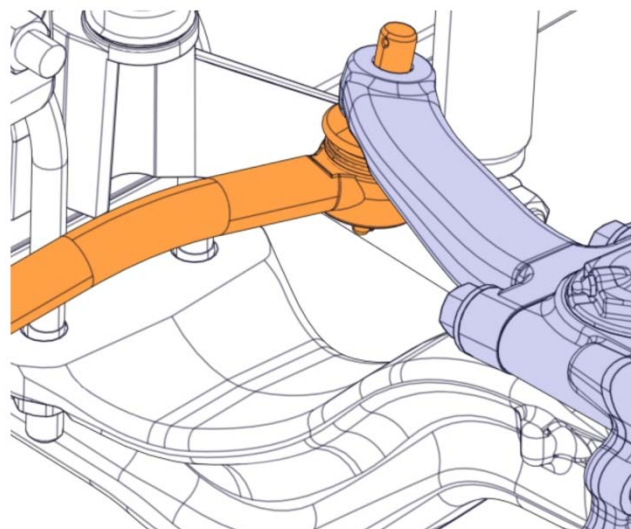

17. Install the replacement castle nut (2) (part number 10506).
18. Tighten the castle nut (part number 10506) to 200 Nm (148 ft-lb) minimum.
19. Turn the castle nut **CLOCKWISE** until the next castle nut slot aligns with the hole in the draglink rod ball socket.
20. Install the split pin (1) (part number 907861).

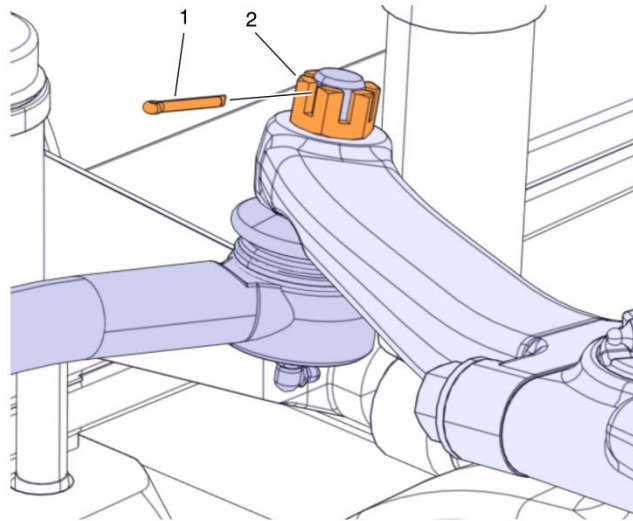

21. Locate the grease fittings shown in the figure below, and lubricate the replacement draglink rod.

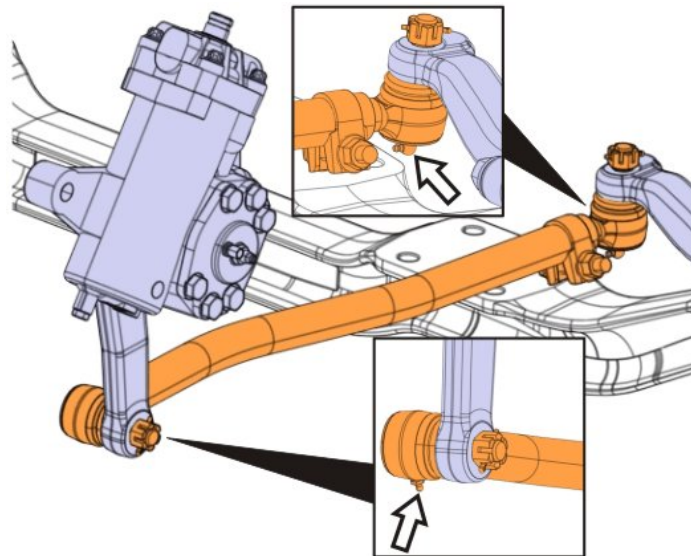

Commissioning the Truck for Operation:

1. Connect the battery cable to the negative (ground) terminal.

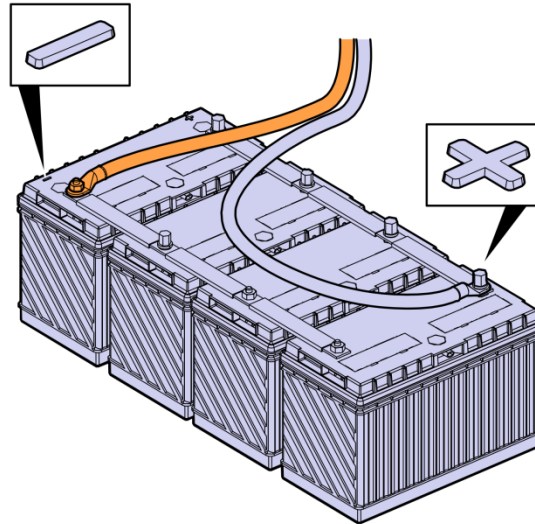

2. Remove the wheel chocks.

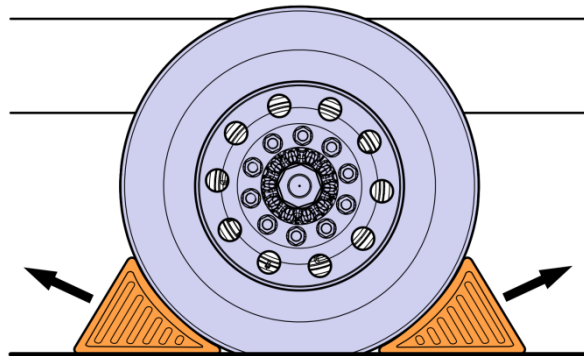

3. Test-drive the truck to ensure proper operation of the replacement drag link.

NOTE

Ensure the steering wheel is correctly positioned before and after test driving the truck.

NOTE

If the steering wheel is not positioned correctly, perform a truck alignment procedure.

Reimbursement:

This repair is covered by an authorized Safety Recall campaign. Reimbursement is obtained through the normal claim handling process.		
	UCHP Reimbursement	eWarranty Reimbursement
Claim Type (used only when uploading from the Dealer Business System)	R	R
Recall Status		
Vehicle repaired per instructions		1-Modified per instructions
Labor Code		
Primary Labor Code (Draglink Rod, Replacement)	6438-03-09-02 0.8 hrs	64306-0-01 0.8 hrs
Time to take charge of vehicle and determine campaign status	1700-16-01-01 0.3 hrs	17003-0-01 0.3 hrs
Causal Part	21657078	21657078
Authorization Number	C6534	RVXX1601

Take-charge time is not included in the labor code for this operation. Take charge may be eligible, but can only be used once per vehicle repair visit. If the vehicle is having other warranty repairs performed, take-charge should be charged to the warranty repair, otherwise take-charge can be charged to this Safety Recall campaign.