

June 2016
FL704A
NHTSA #16V-204

Subject FCCC Motorhome Brake Lights and Towed Device Brakes

Models Affected: Specific Freightliner Custom Chassis XCL, XCM, XCP, and XCR chassis manufactured February 1, 2013, through June 1, 2015, and equipped with a certain adjustable foot pedal.

General Information

Daimler Trucks North America LLC, on behalf of its wholly owned subsidiary, Freightliner Custom Chassis Corporation, has decided that a defect which relates to motor vehicle safety exists on the vehicles mentioned above.

There are approximately 2,925 vehicles involved in this campaign.

On certain motorhome chassis equipped with a certain adjustable foot pedal, the brake activation signal to the brake lights and to certain towed devices may not deactivate when the motorhome service brakes are released. This may cause the motorhome brake lights to potentially remain illuminated, and additionally may cause the brakes on the towed device to remain engaged, depending on brake configuration. A towed device with incorrectly operating brakes could increase the risk of a crash.

To remedy the issue, a new torsion spring will be added to the pedal assembly to improve the pedal return.

Additional Repairs

Dealers must complete all outstanding Recall and Field Service campaigns prior to the sale or delivery of a vehicle. A Dealer will be liable for any progressive damage that results from its failure to complete campaigns before sale or delivery of a vehicle.

Owners may be liable for any progressive damage that results from failure to complete campaigns within a reasonable time after receiving notification.

Work Instructions

Please refer to the attached work instructions. Prior to performing the campaign, check the vehicle for a completion sticker (Form WAR260).

Replacement Parts

Replacement parts are now available and can be obtained by ordering the part number(s) listed below from your facing Parts Distribution Center.

If our records show your dealership has ordered any vehicles involved in campaign number FL704A, a list of the customers and vehicle identification numbers will be available in OWL. Please refer to this list when ordering parts for this recall.

Table 1 - Replacement Parts for FL704A

Campaign Number	Part Description	Part Number	Qty. per VIN
FL704A	SPRING-TORSION,RETURN	12-27994-000	1 ea
	PIN,COTTER,3/32 X 3/4,	23-12066-006	1 ea
	COMPLETION STICKER	WAR260	1 ea

Table 1

Removed Parts

U.S. and Canadian Dealers, please follow Warranty Failed Parts Tracking shipping instructions for the disposition of all removed parts. Export distributors, please destroy removed parts unless otherwise advised.

June 2016
FL704A
NHTSA #16V-204

Labor Allowance

Table 2 - Labor Allowance

Campaign Number	Procedure	Time Allowed (hours)	SRT Code	Corrective Action
FL704A	Inspect for torsion spring only	0.1	996-0980A	06-Inspect
	Inspect and install torsion spring	1.1	996-0980B	12-Repair Recall/Campaign

Table 2

IMPORTANT:When the Recall has been completed, locate the base completion label in the appropriate location on the vehicle, and attach the red completion sticker provided in the recall kit (Form WAR260). If the vehicle does not have a base completion label, clean a spot on the appropriate location of the vehicle and first attach the base completion label (Form WAR259). If a recall kit is not required or there is no completion sticker in the kit, write the recall number on a blank sticker and attach it to the base completion label.

Claims for Credit

You will be reimbursed for your parts, labor, and handling (landed cost for Export Distributors) by submitting your claim through the Warranty system within 30 days of completing this campaign. Please reference the following information in OWL:

- Claim type is **Recall Campaign**.
- In the Campaign field, enter the campaign number and appropriate group (**FL704-A**).
- In the Primary Failed Part field, enter **25-FL704-000**.
- In the Parts section, enter the appropriate part number(s) as shown in the Replacement Parts Table.
- In the Labor section, enter the appropriate SRT from the Labor Allowance Table. Administrative time will be included automatically as SRT 939-6010A for 0.4 hours.
- The VMRS Component Code is **013-005-001** and the Cause Code is **A1 - Campaign**.
- **U.S. and Canada -- Reimbursement for Prior Repairs.** When a customer asks about reimbursement, please do the following:
 - Accept the documentation of the previous repair.
 - Make a brief check of the customer's paperwork to see if the repair may be eligible for reimbursement. (See the "Copy of Owner Letter" section of this bulletin for reimbursement guidelines.)
 - Submit an OWL Recall Pre-Approval Request for a decision.
 - Attach the documentation to the pre-approval request.
 - If approved, submit a based on claim for the pre-approval.
 - Reimburse the customer the appropriate amount.

IMPORTANT: OWL must be viewed prior to performing the recall to ensure the vehicle is involved and the campaign has not been previously completed. Also, check for a completion sticker prior to beginning work.

For questions, U.S. and Canadian dealers, contact the Warranty Campaigns Department from 7:00 a.m. to 4:00 p.m. Pacific Time, Monday through Friday, via Web inquiry at AccessFreightliner.com / Support / My Tickets and Submit an Inquiry, or the Customer Assistance Center at (800) 385-4357, after normal business hours, if you have any questions or need additional information. Export distributors, submit a Web inquiry or contact your International Service Manager.

**June 2016
FL704A
NHTSA #16V-204**

U.S. and Canadian Dealers: To return excess kit inventory related to this campaign, U.S. dealers must submit a Parts Authorization Return (PAR) to the Memphis PDC. Canadian dealers must submit a PAR to their facing PDC. All kits must be in resalable condition. PAR requests must include the original purchase invoice number. Export Distributors: Excess inventory is not returnable.

The letter notifying U.S. and Canadian vehicle owners is included for your reference.

Please note that the National Traffic and Motor Vehicle Safety Act, as amended (Title 49, United States Code, Chapter 301), requires the owner's vehicle(s) be corrected within a reasonable time after parts are available to you. The Act states that failure to repair a vehicle within 60 days after tender for repair shall be prima facie evidence of an unreasonable time. However, circumstances of a particular situation may reduce the 60 day period. Failure to repair a vehicle within a reasonable time can result in either the obligation to (a) replace the vehicle with an identical or reasonably equivalent vehicle, without charge, or (b) refund the purchase price in full, less a reasonable allowance for depreciation. The Act further prohibits dealers from selling a vehicle unless all outstanding recalls are performed. Any lessor is required to send a copy of the recall notification to the lessee within 10 days. Any subsequent stage manufacturer is required to forward this notice to its distributors and retail outlets within five working days.

June 2016
FL704A
NHTSA #16V-204

Copy of Notice to Owners

Subject FCCC Motorhome Brake Lights and Towed Device Brakes

For the Notice to U.S. Customers: This notice is sent to you in accordance with the National Traffic and Motor Vehicle Safety Act. **For the Notice to Canadian Customers:** This notice is sent to you in accordance with the Canadian Motor Vehicle Safety Act.

Daimler Trucks North America LLC, on behalf of its wholly owned subsidiary, Freightliner Custom Chassis Corporation, has decided that a defect which relates to motor vehicle safety exists on specific Freightliner Custom Chassis XCL, XCM, XCP, and XCR chassis manufactured February 1, 2013, through June 1, 2015, and equipped with a certain adjustable foot pedal.

On certain motorhome chassis equipped with a certain adjustable foot pedal, the brake activation signal to the brake lights and to certain towed devices may not deactivate when the motorhome service brakes are released. This may cause the motorhome brake lights to potentially remain illuminated, and additionally may cause the brakes on the towed device to remain engaged depending on brake configuration. A towed device with incorrectly operating brakes could increase the risk of a crash.

To remedy the issue, a new torsion spring will be added to the pedal assembly to improve the pedal return.

Please contact an authorized Daimler Trucks North America dealer to arrange to have the Recall performed and to ensure that parts are available at the dealership. To locate an authorized dealer, search online at www.Daimler-TrucksNorthAmerica.com / Contact Us / Find a Dealer. The Recall will take approximately one hour and will be performed at no charge to you.

You may be liable for any progressive damage that results from your failure to complete the Recall within a reasonable time after receiving notification.

If you do not own the vehicle that corresponds to the identification number(s) which appears on the Recall Notification, please return the notification to the Warranty Campaigns Department with any information you can furnish that will assist us in locating the present owner. If you have leased this vehicle, Federal law requires that you forward this notice to the lessee within 10 days. If you are a subsequent stage manufacturer, Federal law requires that you forward this notice to your distributors and retail outlets within five working days. If you have paid to have this recall condition corrected prior to this notice, you may be eligible to receive reimbursement. Please see the reverse side of this notice for details.

For the Notice to U.S. Customers: If you have questions about this Recall, please contact the Warranty Campaigns Department at (800) 547-0712, 7:00 a.m. to 4:00 p.m. Pacific Time, Monday through Friday, e-mail address DTNA.Warranty.Campaigns@Daimler.com, or the Customer Assistance Center at (800) 385-4357 after normal business hours. If you are not able to have the defect remedied without charge and within a reasonable time, you may wish to submit a complaint to the Administrator, National Highway Traffic Safety Administration, 1200 New Jersey Avenue, SE., Washington, DC 20590; or call the Vehicle Safety Hotline at (888) 327-4236 (TTY: 800-424-9153); or to <http://www.safercar.gov>. **For the Notice to Canadian Customers:** If you have questions about this Recall, please contact the Warranty Campaigns Department at (800) 547-0712, 7:00 a.m. to 4:00 p.m. Pacific Time, Monday through Friday, e-mail address DTNA.Warranty.Campaigns@Daimler.com, or the Customer Assistance Center at (800) 385-4357 after normal business hours.

We regret any inconvenience this action may cause but feel certain you understand our interest in motor vehicle safety.

WARRANTY CAMPAIGNS DEPARTMENT

Enclosure

June 2016
FL704A
NHTSA #16V-204

Reimbursement to Customers for Repairs Performed Prior to Recall

If you have already **paid** to have this recall condition corrected you may be eligible to receive reimbursement.

Requests for reimbursement may include parts and labor. Reimbursement may be limited to the amount the repair would have cost if completed by an authorized Daimler Trucks North America LLC dealer. The following documentation must be presented to your dealer for consideration for reimbursement.

Please provide original or clear copies of all receipts, invoices, and repair orders that show

- The name and address of the person who paid for the repair
- The Vehicle Identification Number (VIN) of the vehicle that was repaired
- What problem occurred, what repair was done, when the repair was done
- Who repaired the vehicle
- The total cost of the repair expense that is being claimed
- Proof of payment for the repair (such as the front and back of a cancelled check or a credit card receipt)

Reimbursement will be made by check from your Daimler Trucks North America LLC dealer.

Please speak with your Daimler Trucks North America LLC authorized dealer concerning this matter.

June 2016
FL704A
NHTSA #16V-204

Work Instructions

Subject: FCCC Motorhome Brake Lights and Towed Device Brakes

Models Affected: Specific Freightliner Custom Chassis XCL, XCM, XCP, and XCR chassis manufactured February 1, 2013, through June 1, 2015, and equipped with a certain adjustable foot pedal.

Torsion Spring Installation

1. Check the base label (Form WAR259) for a completion sticker for FL704 (Form WAR260), indicating this work has been done. The base label is usually located on the front wall under the dash. If a sticker is present, no work is needed. If there is no sticker, proceed with the next step.
2. Park the vehicle on a level surface, shut down the engine, and set the parking brake. Chock the tires.
3. Inspect the brake pedal assembly for a torsion spring.

If a torsion spring is found, no further work is needed. Clean a spot on the base label (Form WAR259). Write the recall number, FL704, on a blank red completion sticker (Form WAR260), and attach it to the base label to indicate this campaign has been performed.

If no torsion spring is found, proceed to the next step.

NOTE: Two technicians are needed to remove and install the accelerator assembly; the mounting bolts are on the outside of the firewall.

4. Remove the accelerator assembly.
5. Remove and discard the cotter pin. See [Fig. 1](#), item 2.

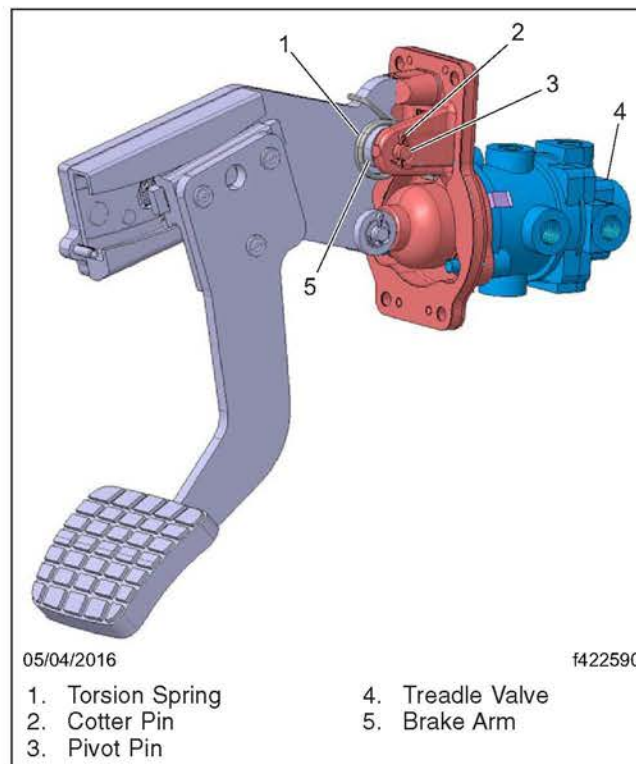

Fig. 1, Brake Pedal Assembly

June 2016
FL704A
NHTSA #16V-204

6. Using a blunt tool, push the pivot pin out.
7. Install the new torsion spring on the service brake pedal. See [Fig. 1](#), item 1.
8. Install the pivot pin removed earlier.
9. Install the new cotter pin, bending the ends of the pin over to secure it in place.
10. Install the accelerator assembly.
11. Start the vehicle. When the air tanks have reached approximately 65 to 76 psi (448 to 524 kPa), depress and release the brake pedal several times. Exit the vehicle and verify that the brake lights are not activated.
12. Clean a spot on the base label (Form WAR259). Write the recall number, FL704, on a blank red completion sticker (Form WAR260), and attach it to the base label to indicate this campaign has been performed.