



## Brake Drum, Replacement Steer Axle CHU, CXU, GU, TD

### FSB 511-002, Brake Drum, Replacement (Steer Axle)

(August 2014)

Some MACK CHU, CXU, GU, and TD trucks built between 08/29/2011 and 06/30/2014, equipped with a MACK 14.6k steer axle, unitized hub, and 152 mm (6.0 in) wide Bendix brake shoes can show signs of brake shoe protrusion beyond the brake drum. This condition is resolved by installing new 152 mm (6.0 in) brake shoes, 178 mm (7.0 in) wide brake drums (20536276), new dust shields, and replace the existing Z-Brackets.

**Note:** This Bulletin does not apply to MACK Trucks Australia.

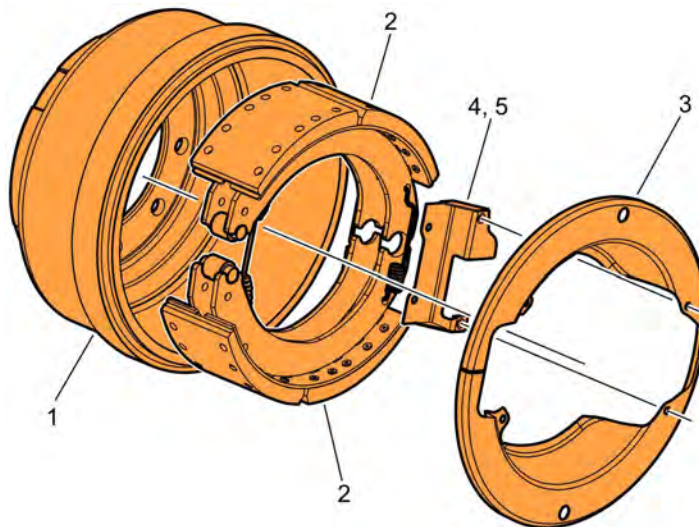

W5092612

### Required Parts (Brake Drum, Replacement)

Brake Drum Replacement Parts			
Item	Description	Part Number	Qty
1	Brake Drum, 178 mm (7.0 in) wide	20536276	2
2	Brake Shoe Kit, 152 mm (6.0 in), Bendix	745-K097965	2
3	Dust Shield, Bendix	22375164	2
4	Z-Bracket, LH	22375312	1
5	Z-Bracket, RH	22375315	1

## Decommissioning the Truck for Repair

You must read and understand the precautions and guidelines in Service Information, group 50, "General Safety Practices, Brakes" before performing this procedure. If you are not properly trained and certified in this procedure, ask your supervisor for training before you perform it.

**NOTE:** Information is subject to change without notice. Illustrations are used for reference only and can differ slightly from the actual vehicle being serviced. However, key components addressed in this information are represented as accurately as possible.

- 1 Park the vehicle on a flat and level surface.
- 2 Apply the parking brake.
- 3 Place the transmission in neutral or park.
- 4 Install the wheel chocks.

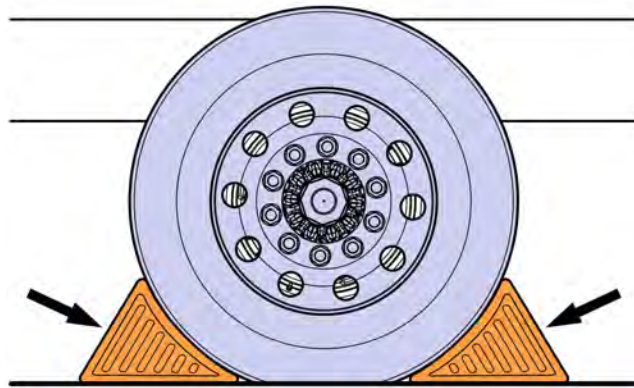

W7086748

- 5 Disconnect the cable from the battery's negative terminal.

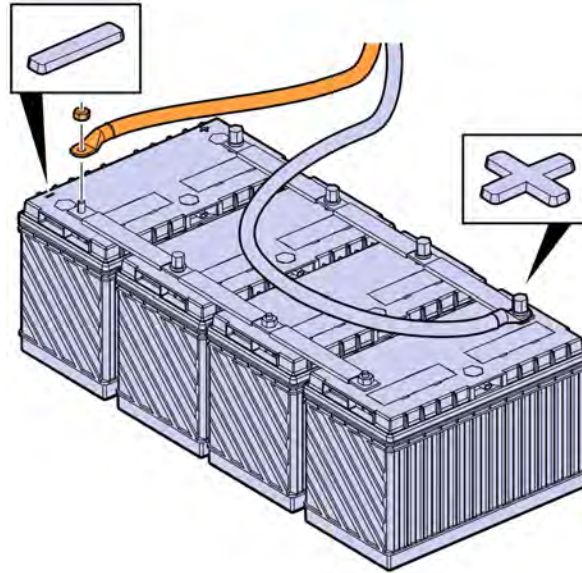

W3086747

## Brake Drum, Replacement, Bendix (1.0 hrs)

**Note:** The right side is shown for instructional purposes.

**Note:** The Hendrickson axle with a tapered hub is shown. However, the brake drum replacement procedure for a MACK axle with unitized hub is the same.

- 1 Lift the steer axle with a jack, place the truck on jack stands, and remove the jack.
- 2 Remove the wheel nuts.

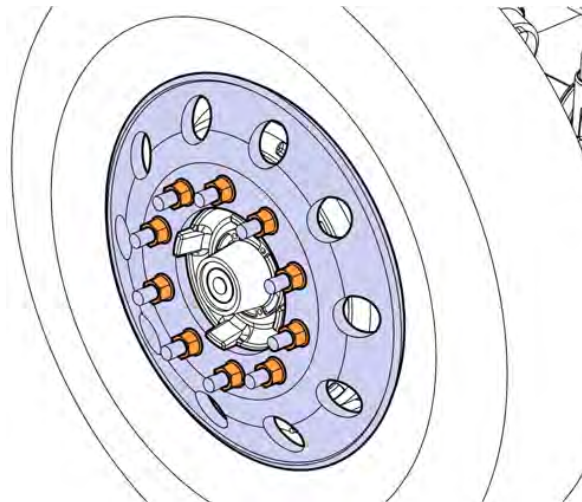

W5092465

3 Remove the wheel.

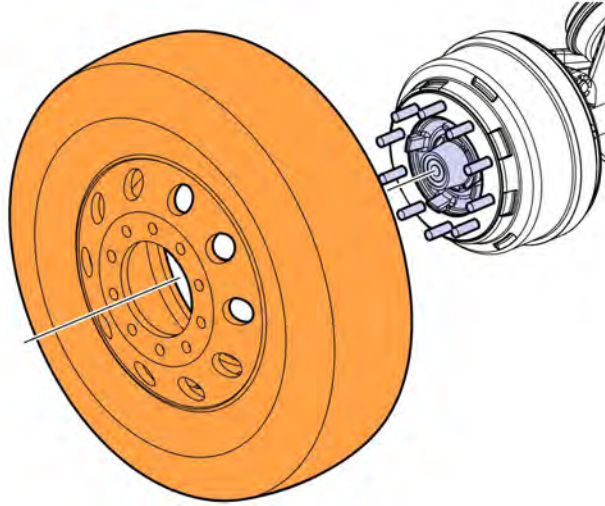

W5092466

4 Remove the four fasteners securing the existing dust Shield.

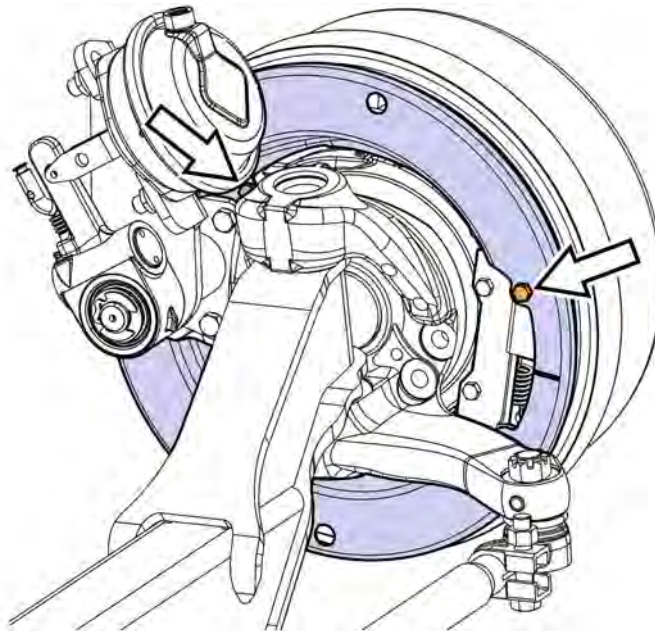

W5092646



5 Remove the dust shield.

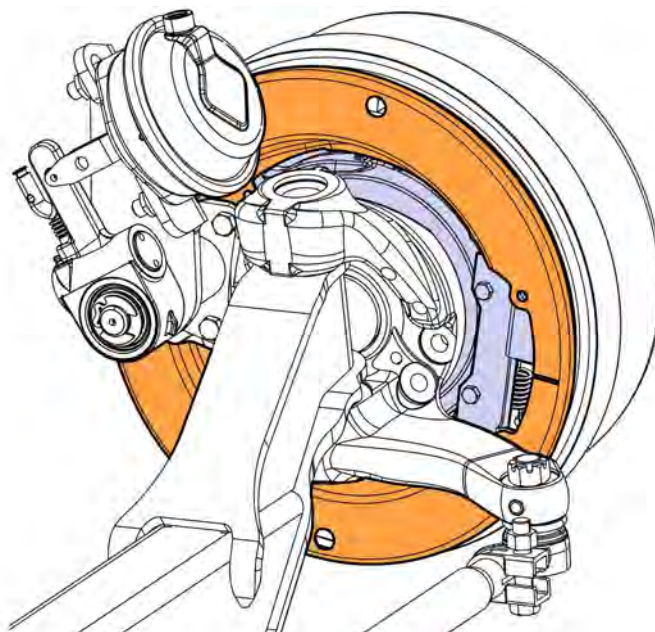

W5092647

6 Remove the fasteners securing the existing z-bracket.

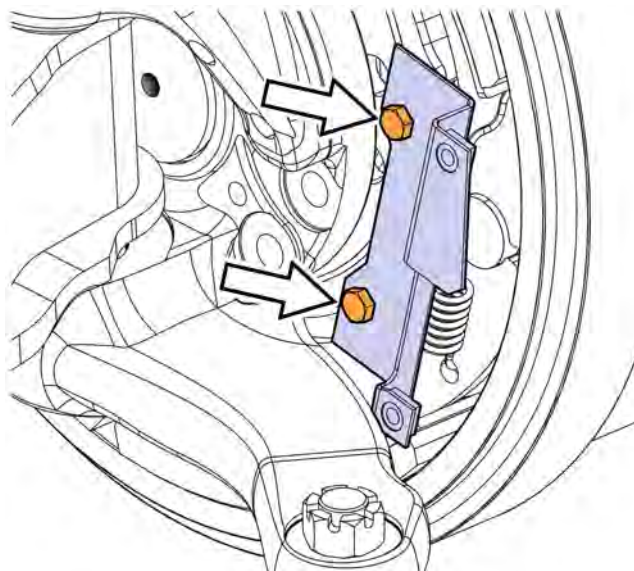

W5092615

- 7 Remove the existing z-bracket.

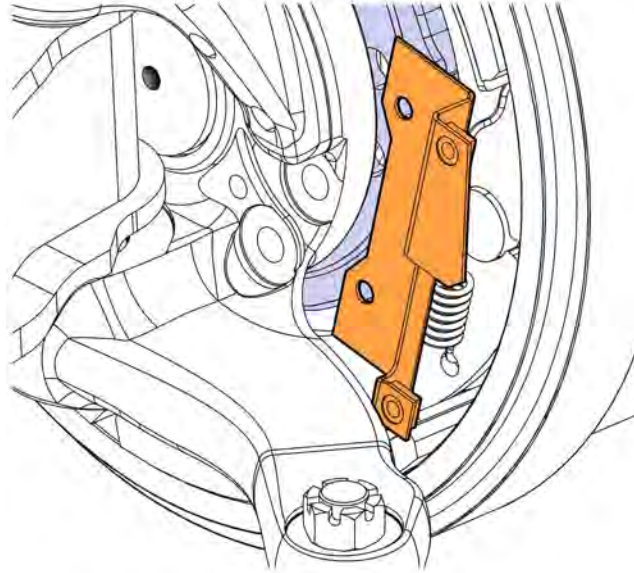

W5092616

- 8 Back off of the brake (slack adjuster).

**Note:** The Gunite slack adjuster is shown in this procedure for backing off the brakes. However, this procedure is similar for other brands.

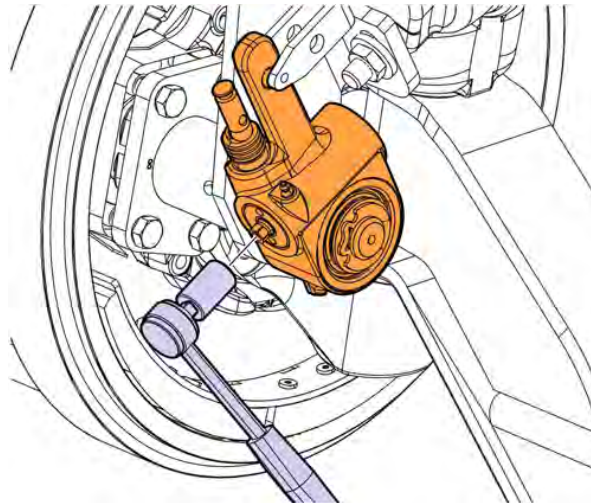

W5092617

9 Remove the brake drum.

**Note:** Discard the brake drum.

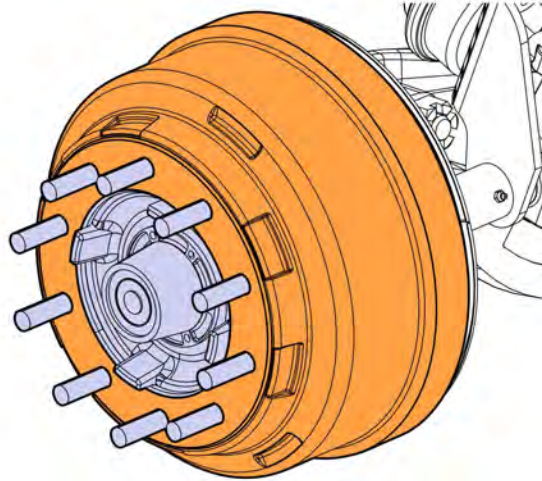

W5092468

10 Remove the brake shoes, brake springs, and rollers.

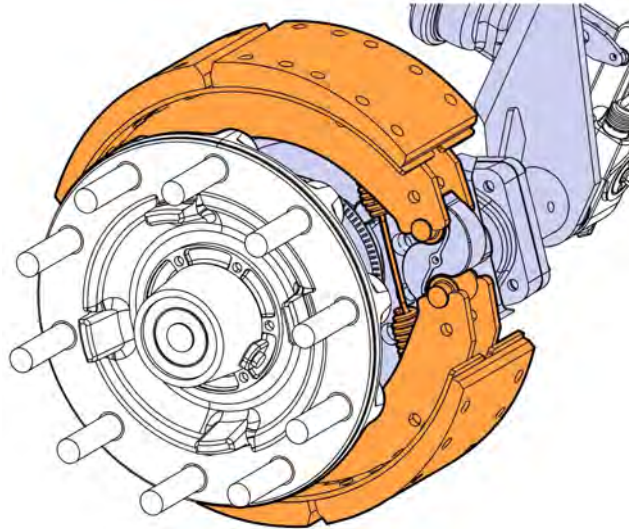

W5092618

11 Install the replacement brake shoes, brake springs and rollers.

**Note:** The brake springs, and rollers are included in the brake shoe kit.

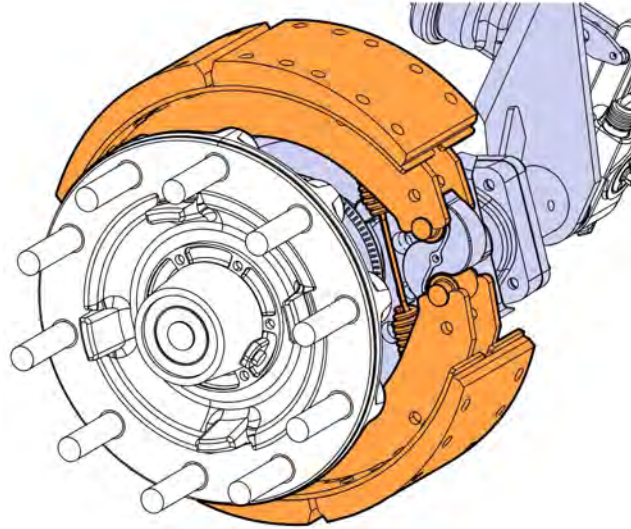

W5092618

12 Install the new z-bracket. See the table on page 1 for the correct part numbers.

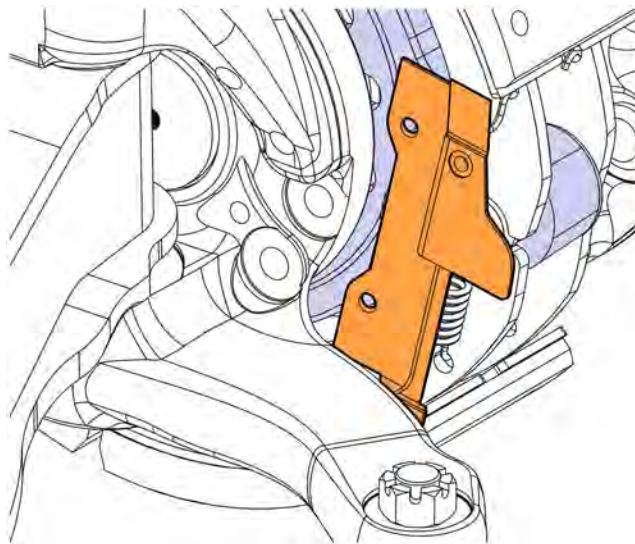

W5092619



13 Install the fasteners securing the z-bracket. See the table on page 1 for the correct part numbers.

14 Tighten the fasteners to  $40 \pm 5$  Nm ( $29 \pm 3$  ft-lb).

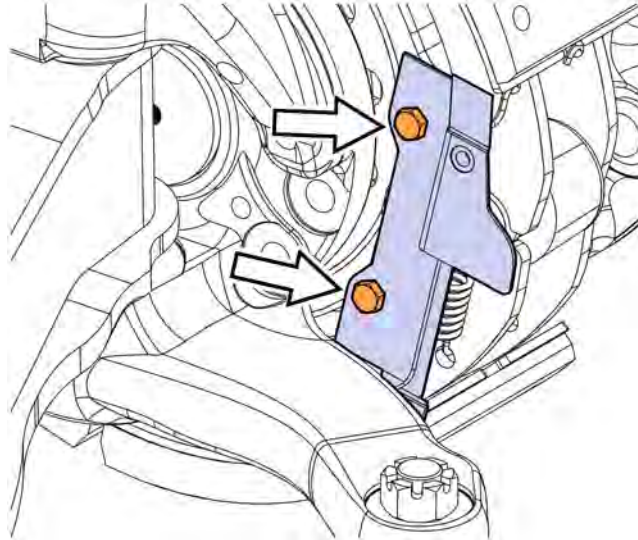

W5092620

15 Install new dust shield. See the table on page 1 for the correct part numbers.

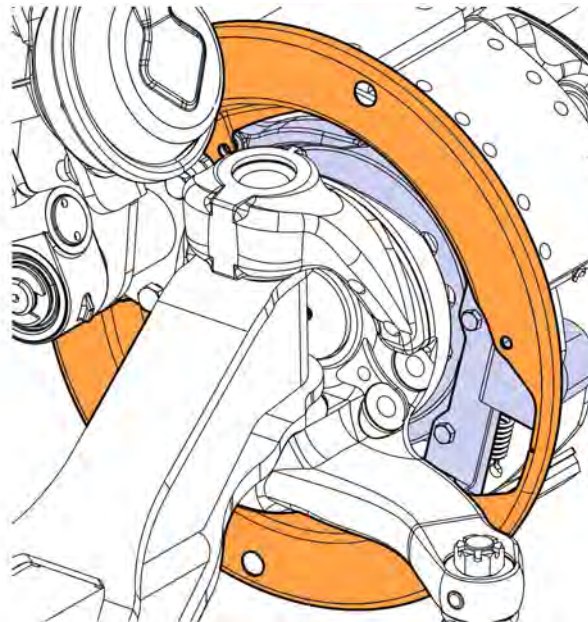

W5092621

16 Install the four fasteners securing the dust shield.

17 Tighten dust shield fasteners to  $40 \pm 5$  Nm ( $29 \pm 3$  ft-lb).

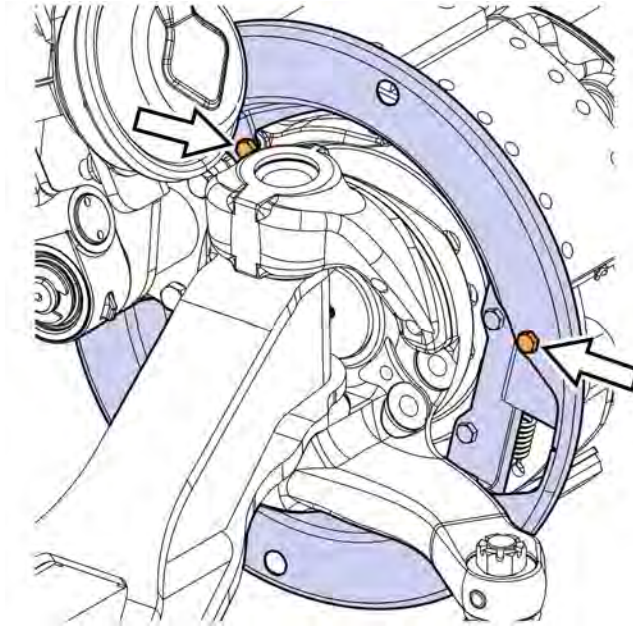

W5092622

18 Install the replacement brake drum (178 mm (7.0 in) wide). See the table on page 1 for the correct part numbers.

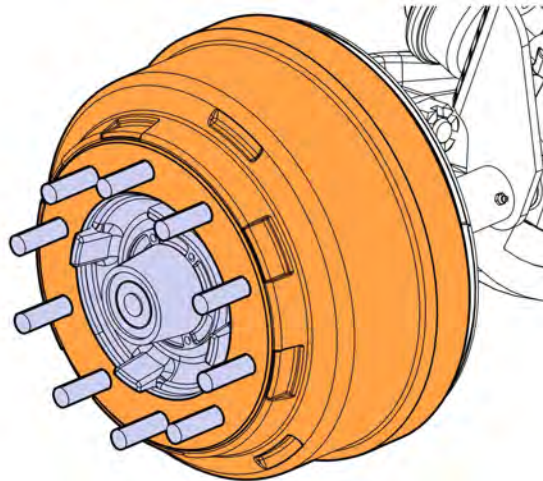

W5092468

19 If applicable, loosen the brake chamber clamp and re-position the clamp at a 45° angle or until proper clearance of the wheel is obtained. See figure below.

**Note:** Do not rotate the brake chamber. Rotate the clamp only.

**Note:** Ensure the brake chamber clamp does not interfere with the dust shield or drum.

20 If applicable, tighten the brake chamber clamp fastener to  $44 \pm 4$  Nm ( $32 \pm 3$  ft-lb).

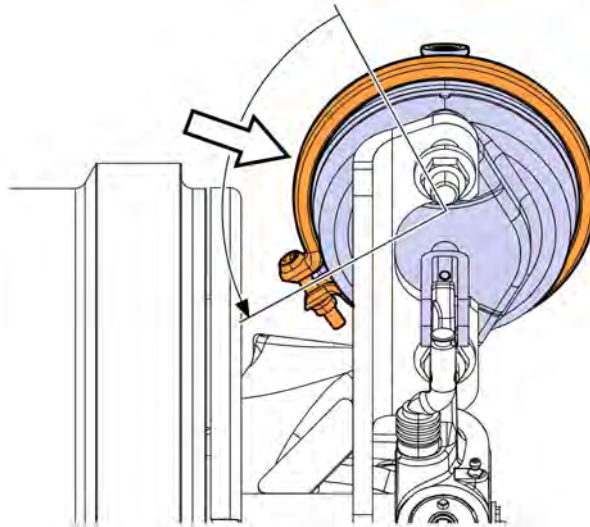

W5092623

21 Install the wheel.

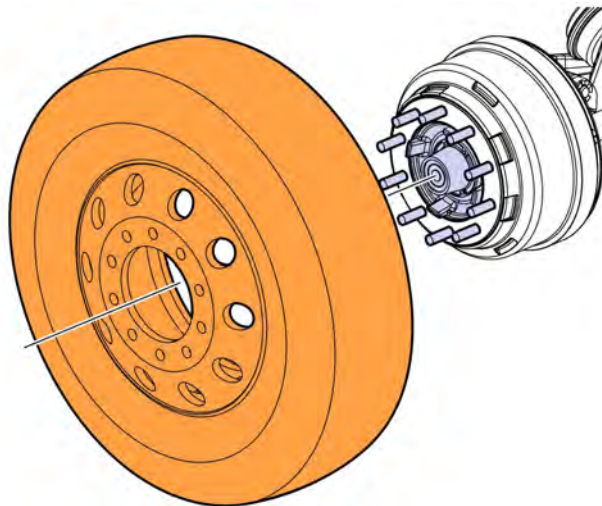

W5092466

22 Install the wheel nuts.

23 Tighten the wheel nuts to 610 Nm (450 ft-lb).

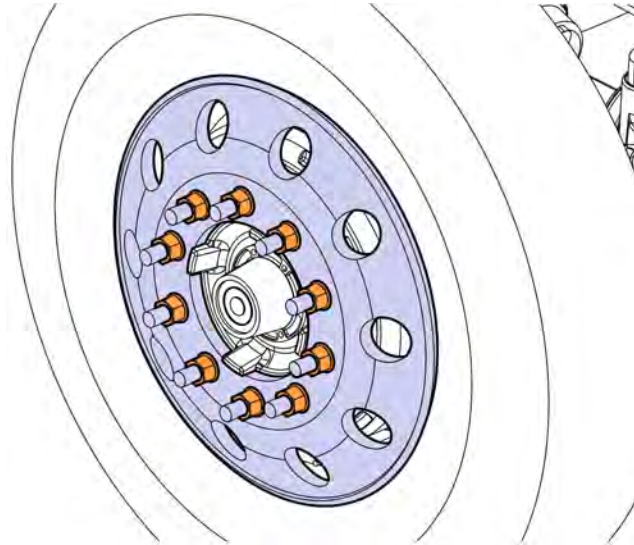

W5092465

24 Adjust the brake as recommended per (slack adjuster) manufacturer.

**Note:** The Gunite slack adjuster is shown in this procedure for adjusting the brake. However, this procedure is similar for other brands.

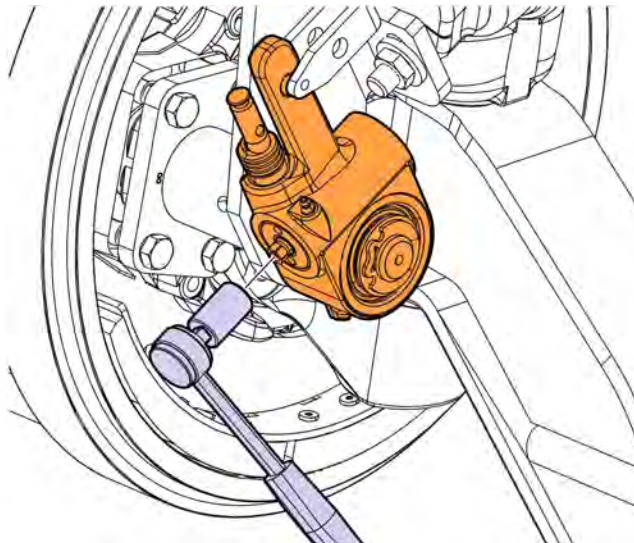

W5092617

25 Repeat steps 1 through 24 for the left side of the truck.

26 Lift the steer axle with a jack, remove the jack stands, and lower the axle.

27 Go to Commissioning the Truck for Operation.



## Commissioning the Truck for Operation

- 1 Connect the battery cable to the negative (ground) terminal.

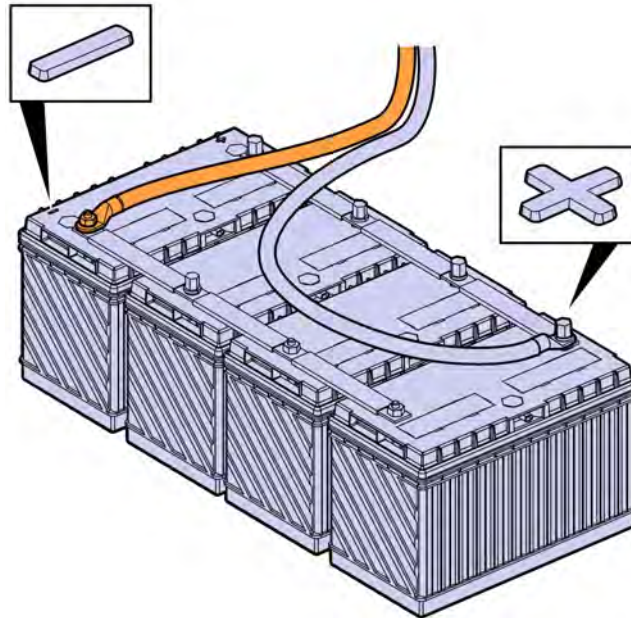

W3086758

- 2 Remove the wheel chocks.

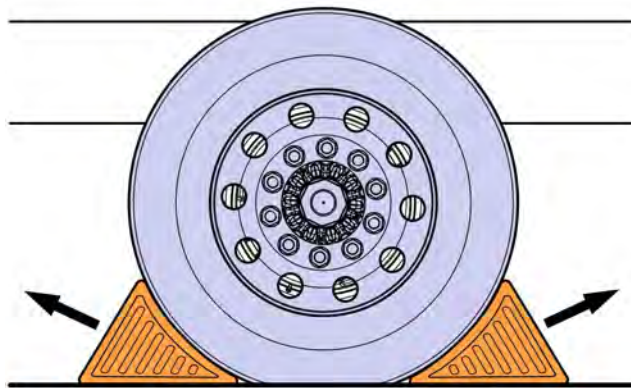

W7086759

**Reimbursement**

<b>This repair may be eligible for reimbursement if a product failure was experienced within time and mileage limits of the applicable Warranty coverage. Reimbursement is obtained via the normal claim handling process.</b>	<b>UCHP Reimbursement</b>	<b>eWarranty Reimbursement</b>
<b>Claim Type (used only when uploading from the Dealer Bus. Sys.)</b>	01	01
<b>Labor Code</b>		
Primary Labor Code (Brake Drum, Replacement)	5112-03-09-01 1.0 hrs.	5126A-01-80 1.0 hrs.
<b>Causal Part</b>	25017906	25017906

MACK Trucks North America reserves the right to make any changes in design or to make additions to or upon its products without incurring any obligations to install the same on vehicles previously built.