



Brake Drum, Replacement
Steer Axle
CHU, CXU, GU, TD

FSB 511-009, Brake Drum, Replacement (Steer Axle)

(August 2014)

Some MACK CHU, CXU, GU, and TD trucks built between 08/29/2011 and 06/30/2014, equipped with a 14.6k steer axle, and 152 mm (6.0 in) wide Meritor or Bendix brake shoes can show signs of brake shoe protrusion beyond the brake drum. This condition is resolved by installing new 152 mm (6.0 in) brake shoes, and new 178 mm (7.0 in) wide brake drums (20536276).

Note: This bulletin does not apply to MACK Trucks Australia.

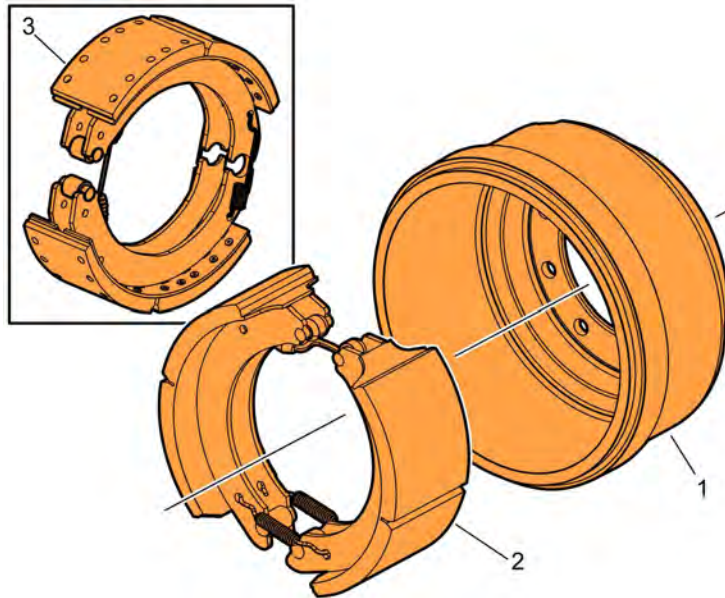

W5092782

Required Parts (Brake Drum Replacement)

Item	Description	Part Number	Qty
1	Brake Drum, 178 mm (7.0 in) wide	20536276	2
2	Meritor Brake Shoe Kit, 152 mm (6.0 in)	8235-KSMA15014715QP	2
3	Bendix Brake Shoe Kit, 152 mm (6.0 in)	745-K097965	2

Decommissioning the Truck for Repair

You must read and understand the precautions and guidelines in Service Information, group 50, "General Safety Practices, Brakes" before performing this procedure. If you are not properly trained and certified in this procedure, ask your supervisor for training before you perform it.

NOTE: Information is subject to change without notice. Illustrations are used for reference only and can differ slightly from the actual vehicle being serviced. However, key components addressed in this information are represented as accurately as possible.

- 1 Park the vehicle on a flat and level surface.
- 2 Apply the parking brake.
- 3 Place the transmission in neutral or park.
- 4 Install the wheel chocks.

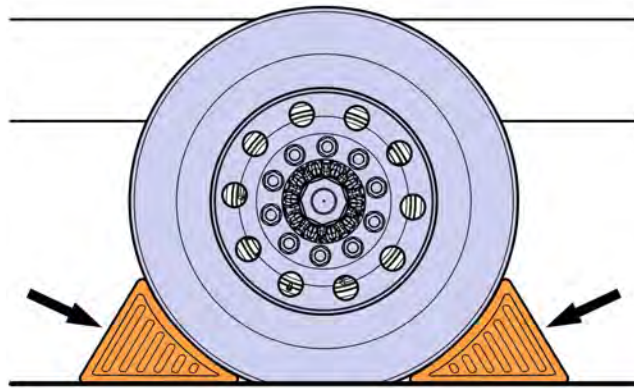

W7086748

- 5 Disconnect the cable from the battery's negative terminal.

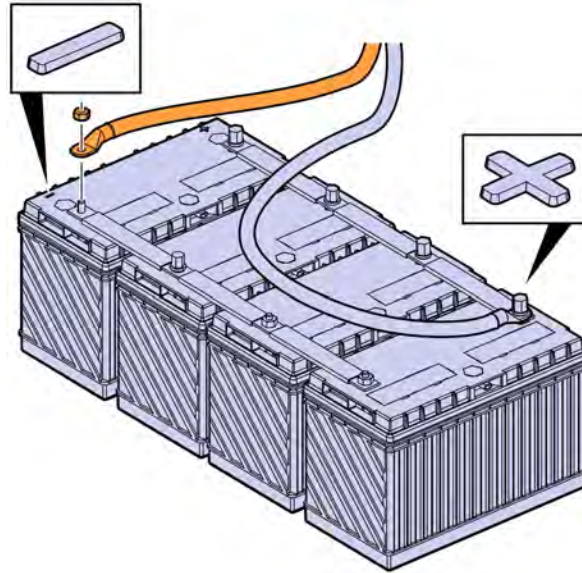

W3086747

Brake Drum, Replacement, Meritor/Bendix (0.9 hrs)

Note: The left side is shown for instructional purposes.

- 1 Lift the steer axle with a jack, place the truck on jack stands, and remove the jack.
- 2 Remove the wheel nuts.

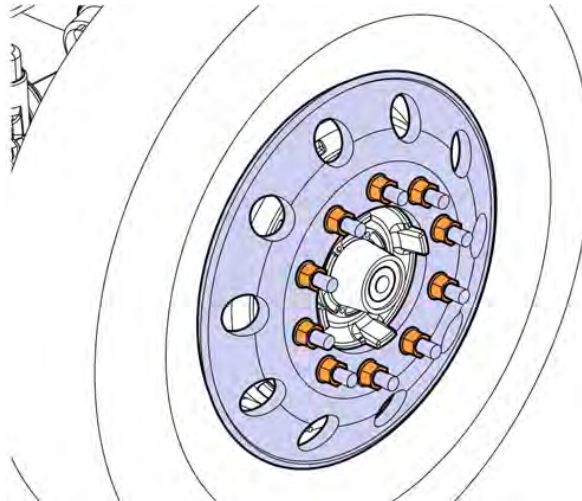

W5092265

3 Remove the wheel.

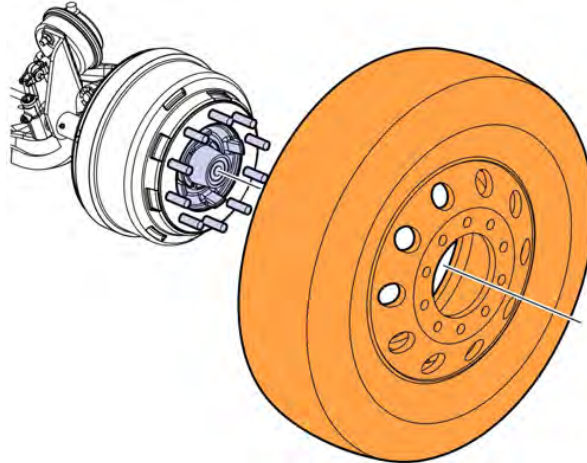

W5092266

4 Remove the slack adjuster pawl.

Note: The Meritor slack adjuster is shown in this procedure for backing off the brakes. However, this procedure is similar for other brands.

Note: For Gunitite slack adjuster backing off of the brake procedures, go to step 6.

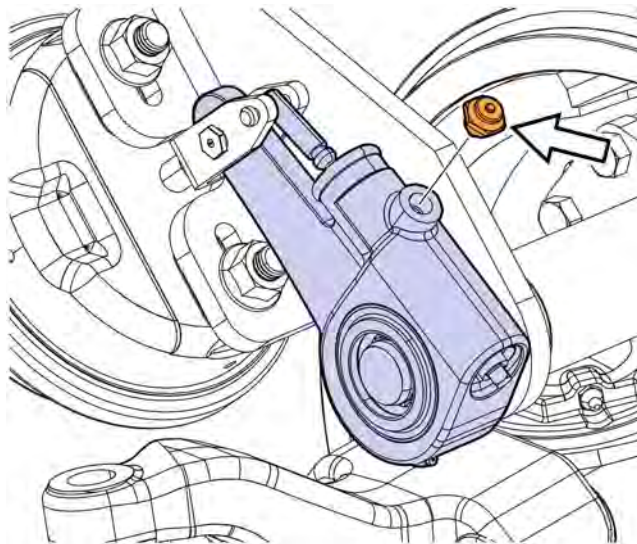

W5092669

5 Back off of the brake (slack adjuster).

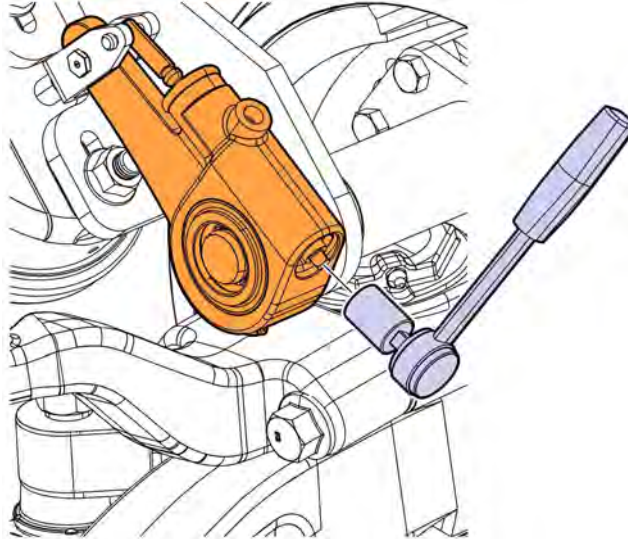

W5092670

6 Back of the brake (slack adjuster).

Note: The Gunite slack adjuster is shown in this procedure for backing off the brakes. However, this procedure is similar for other brands.

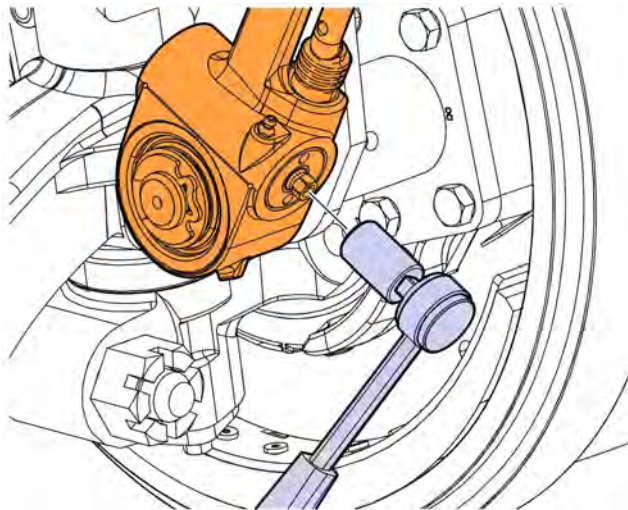

W5092783

7 Remove the brake drum.

Note: Discard the brake drum.

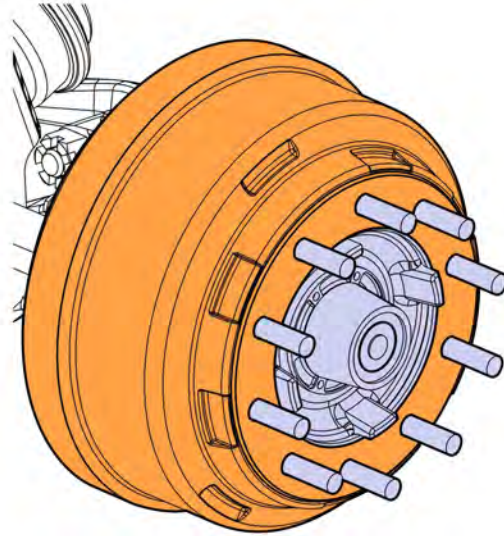

W5092271

8 Remove the brake shoes, brake springs, and rollers.

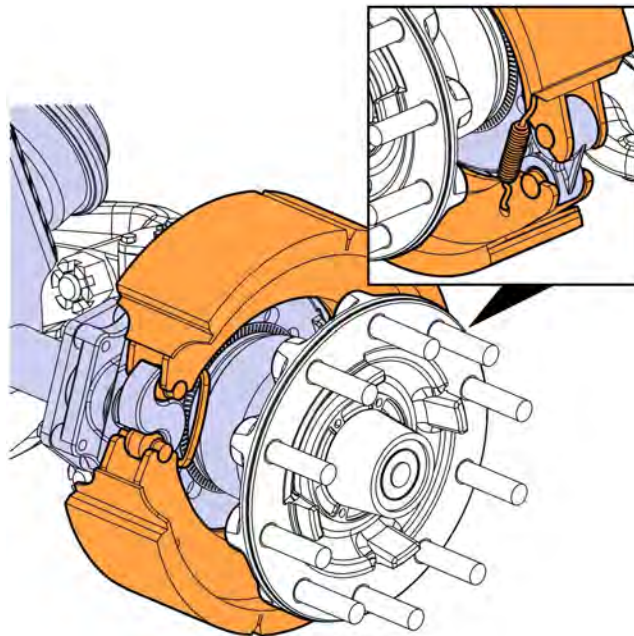

W5092272

9 Install the replacement brake shoes, springs and rollers.

Note: The brake springs and rollers are included in the brake shoe kit.

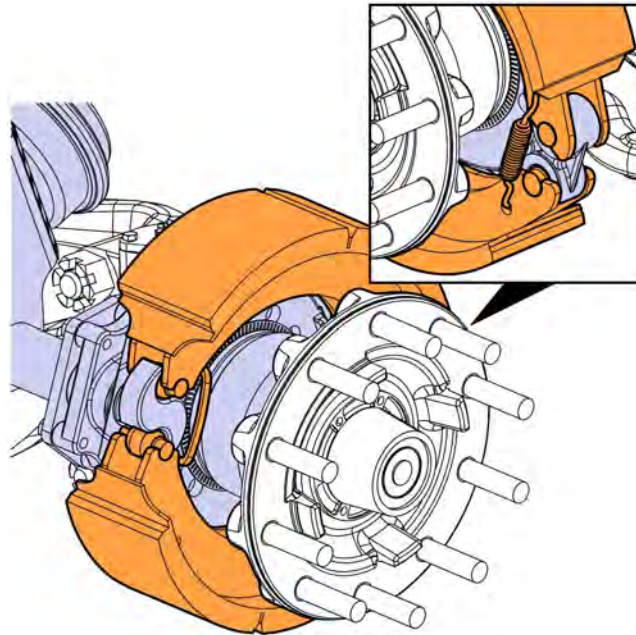

W5092272

10 Install the replacement brake drum (178 mm (7.0 in) wide). See the table on page 1 for the correct part number.

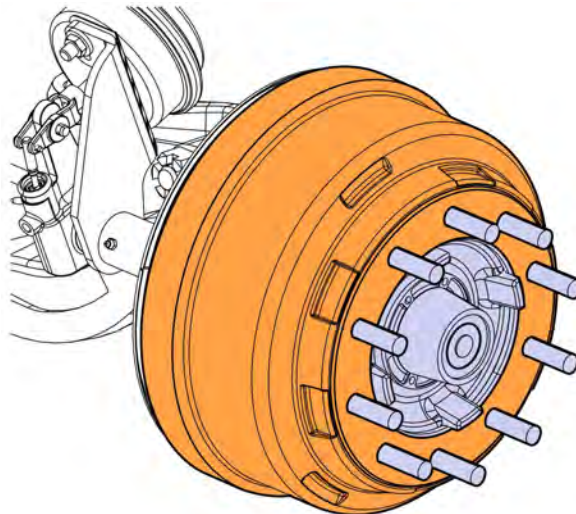

W5092276

11 If applicable, loosen the brake chamber clamp and re-position the clamp at a 45° angle or until proper clearance of the wheel is obtained. See figure below.

Note: Do not rotate the brake chamber. Rotate the clamp only.

Note: Ensure the brake chamber clamp does not interfere with the drum.

12 If applicable, tighten the brake chamber clamp fastener to 44 ± 4 Nm (32 ± 3 ft-lb).

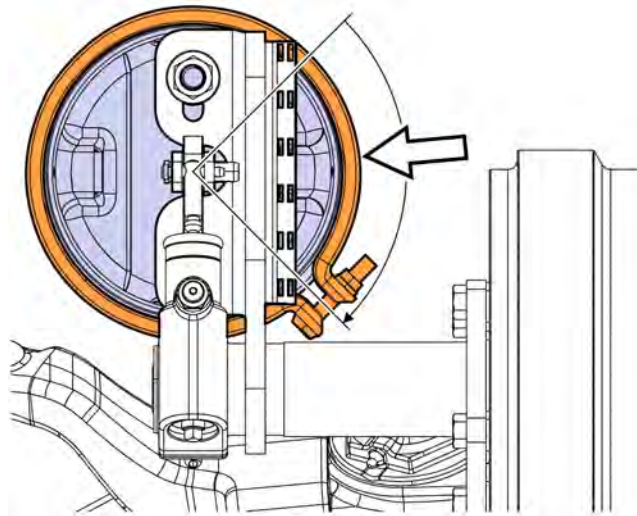

W5092784

13 Install the wheel.

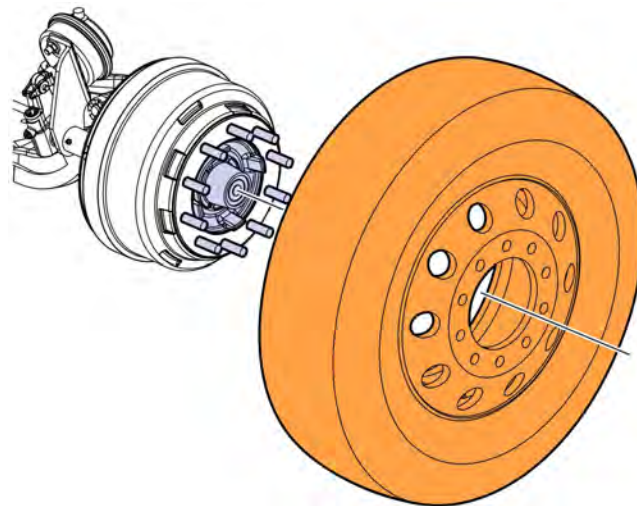

W5092266

14 Install the wheel nuts.

15 Tighten the wheel nuts to 610 Nm (450 ft-lb).

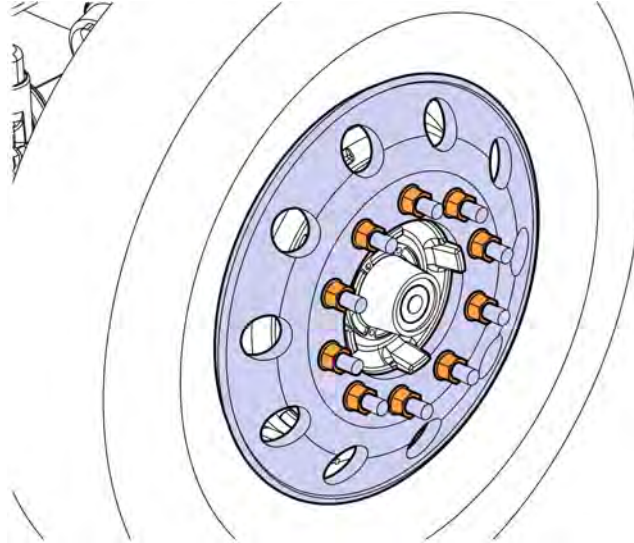

W5092265

16 Adjust the brake as recommended per (slack adjuster) manufacturer.

Note: The Meritor slack adjuster is shown in this procedure for adjusting the brake. However, this procedure is similar for other brands.

Note: For Gunitite brake adjustment procedures, go to step 19.

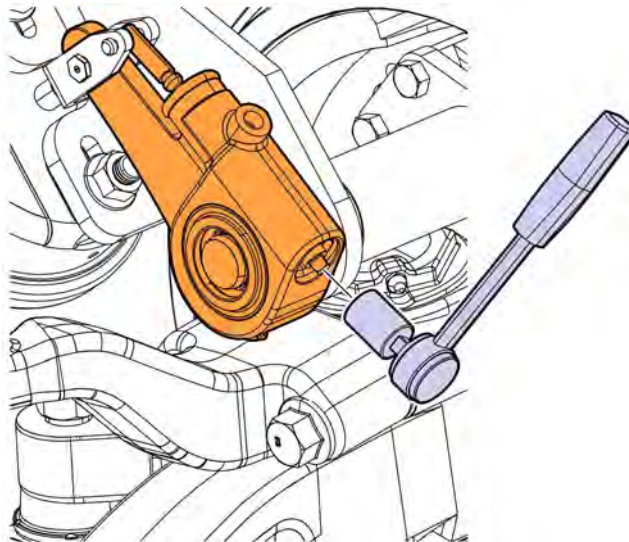

W5092670

17 Install the slack adjuster pawl.

18 Tighten the slack adjuster pawl to 21 ± 3 Nm (186 ± 30 in-lb).

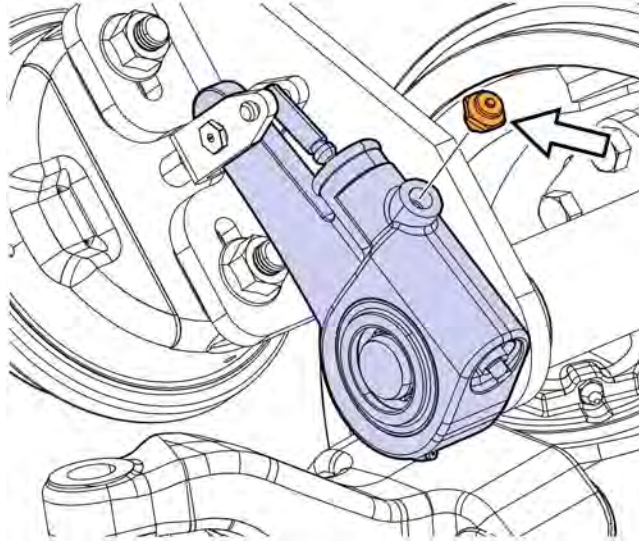

W5092669

19 Adjust the brake as recommended per (slack adjuster) manufacturer.

Note: The Gunite slack adjuster is shown in this procedure for adjusting the brake. However, this procedure is similar for other brands.

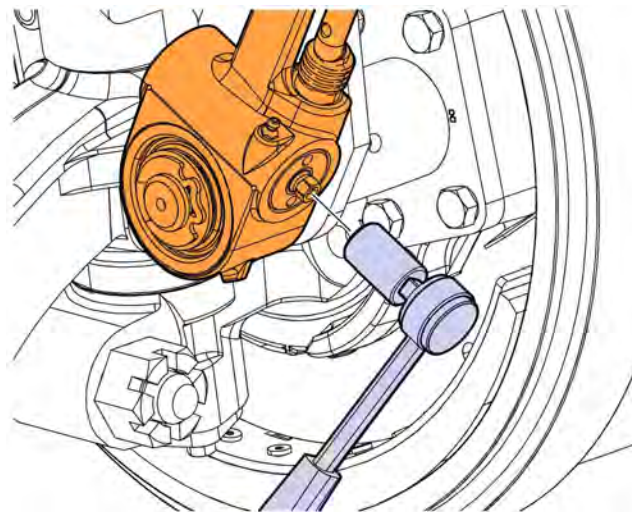

W5092783

- 20 Repeat steps 1 through 19 for the right side of the truck.
- 21 Lift the steer axle with a jack, remove the jack stands, and lower the axle.
- 22 Go to Commissioning the Truck for Operation.

Commissioning the Truck for Operation

- 1 Connect the battery cable to the negative (ground) terminal.

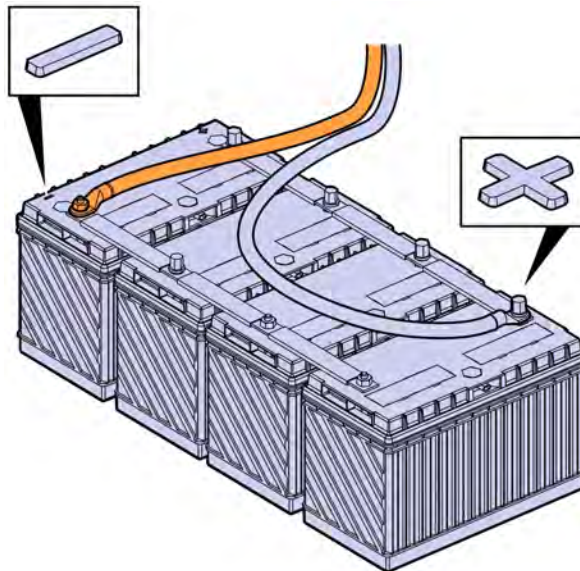

W3086758

- 2 Remove the wheel chocks.

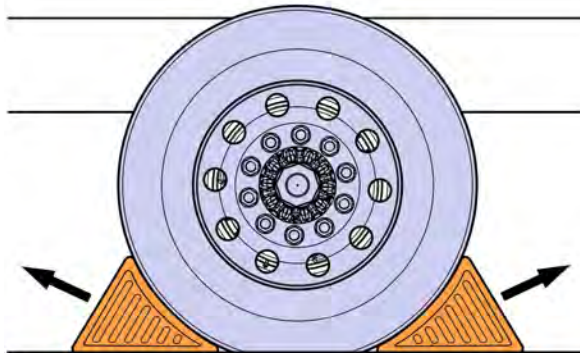

W7086759

Reimbursement

This repair may be eligible for reimbursement if a product failure was experienced within time and mileage limits of the applicable Warranty coverage. Reimbursement is obtained via the normal claim handling process.	UCHP Reimbursement	eWarranty Reimbursement
Claim Type (used only when uploading from the Dealer Bus. Sys.)	01	01
Labor Code		
Primary Labor Code (Brake Drum, Replacement)	5112-03-09-08 0.9 hrs.	5126C-01-80 0.9 hrs.
Causal Part	25017906	25017906

MACK Trucks North America reserves the right to make any changes in design or to make additions to or upon its products without incurring any obligations to install the same on vehicles previously built.