



Date	Group	No.	Release	Page
12.2012	<b>371</b>	<b>802</b>	<b>01</b>	1(8)

## Battery Cable Routing CXU

### PI0802, Battery Cable Routing

(December 2012)

On certain Mack Trucks built between August 14, 2009 to October 21, 2011, the battery cables may rub on the over slung cross member. The cable contact point is located between the clutch housing and the clipping point on the frame behind the battery box. This is due to improper routing of the cables.

To correct this issue follow the procedures below.

**Note:** This bulletin does not apply to MACK Australia.

### Required Parts

Quantity	Part Number	Description
2	20378961	4 battery configuration
1	20378961	3 battery configuration
1	995462 (975197)	M8 x 30 bolt
1	965558	Bracket
1	990950	Nut
A/R	8079360	Double Headed Cable Tie
A/R	948211	Cable Tie

If **new clamp** is required use parts below:

Quantity	Part Number	Description
1	21658909	Clamp
1	994950	Spring Nut
1	995536	Bolt

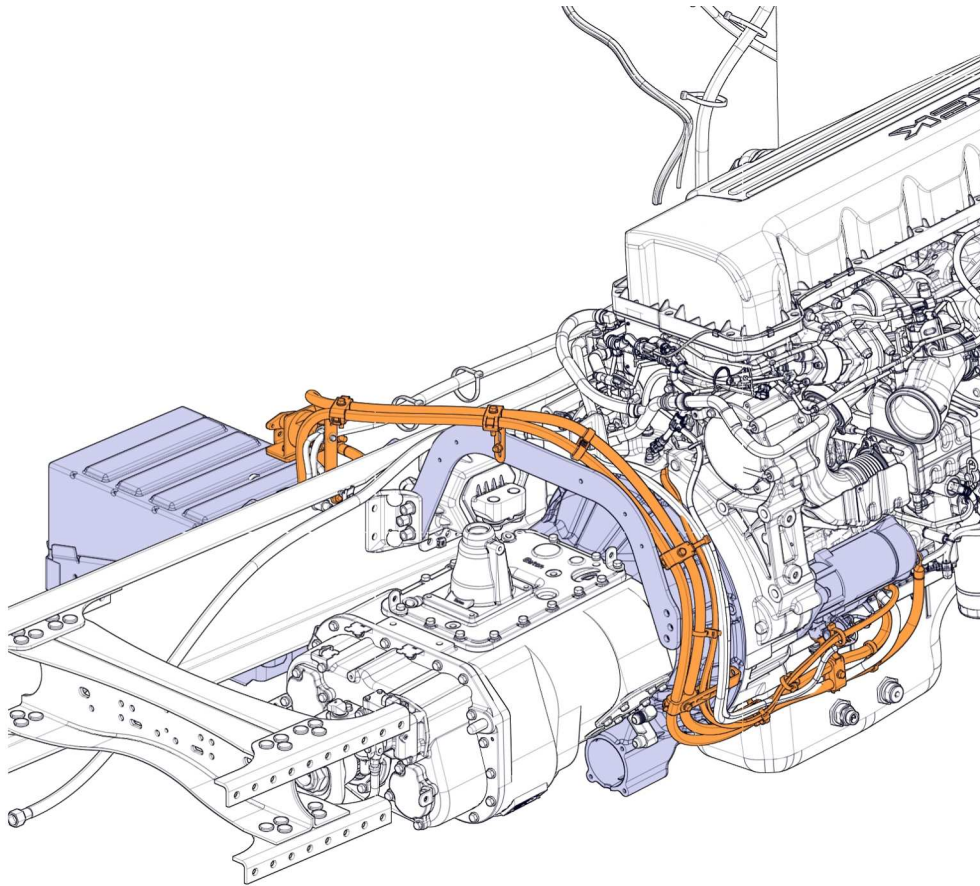

W3077591

You must read and understand the precautions and guidelines in Service Information, group 20, "General Safety Practices, Engine" before performing this procedure. If you are not properly trained and certified in this procedure, ask your supervisor for training before you perform it.

## Repair

- 1 Disconnect batteries.
- 2 Remove drivers seat and attachments.
- 3 Remove the shifter knob, airlines and boot.

**Note:** Mark airline location for future reference.

- 4 Remove center floor mat.
- 5 Remove center floor pan.

- 6 Remove battery cables from the bracket at frame edge.

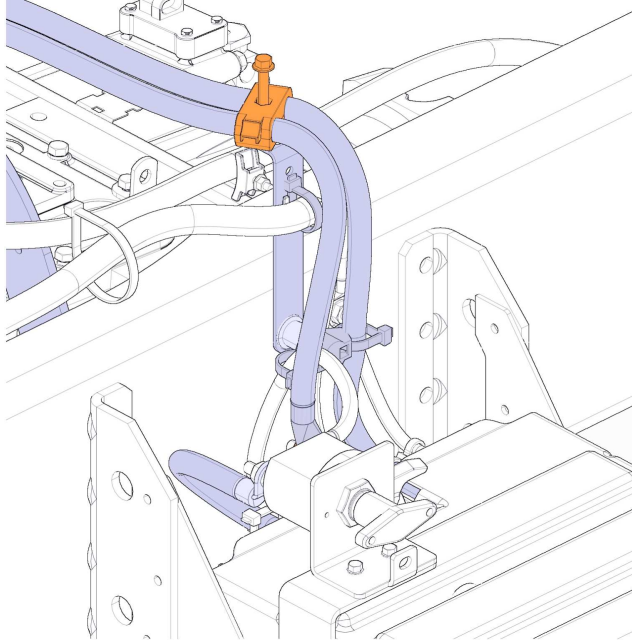

W3077593

- 7 Remove and discard bolt (1) and L-bracket (3), remove bolt (2) then re-install bolt (2) to secure air discharge line.

**Note:** Battery cable clamp can be removed from the L-bracket and reused in next step.

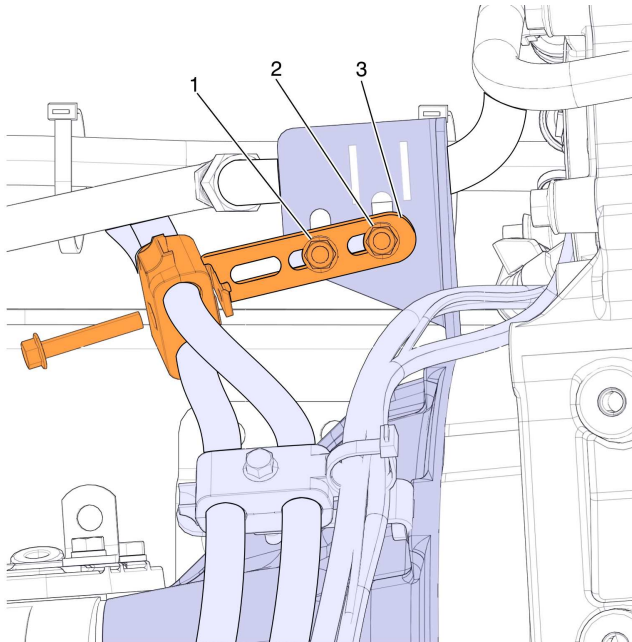

W3077675

- 8 Install the new L-bracket onto the over slung cross member in the position as indicated.  
Torque to 8.8 Nm (77 in lb).  
Install spring nut onto L-bracket and then install the new battery clamp or the one removed in previous step.

**Note:** Use the lower slot in the upper position

**Note:** Replace defective cable(s) if there are areas on the coating that have been heavily chaffed, cut or worn to the point where the copper is exposed, before proceeding with new routing and clipping procedures.

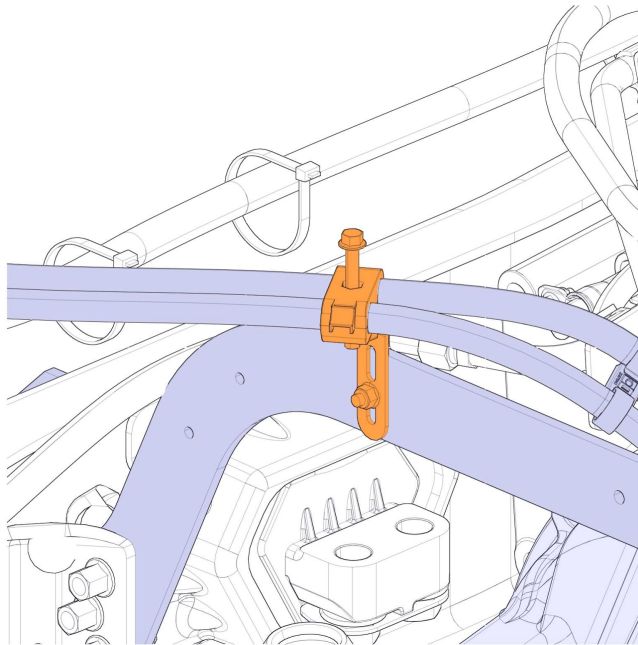

W3077592

9 Lay the battery cables in place at the frame edge.

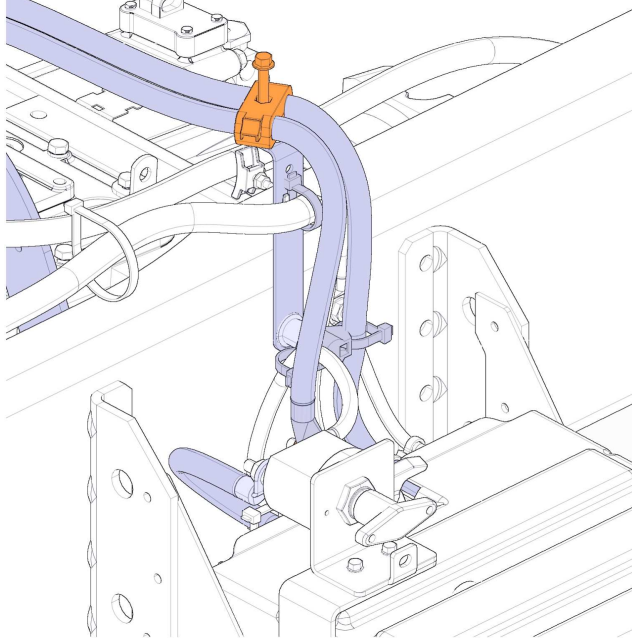

W3077593

10 Remove battery cable bracket and clamp. Reinstall bolt into bell housing .  
Torque to 68 Nm (50 ft lbs).

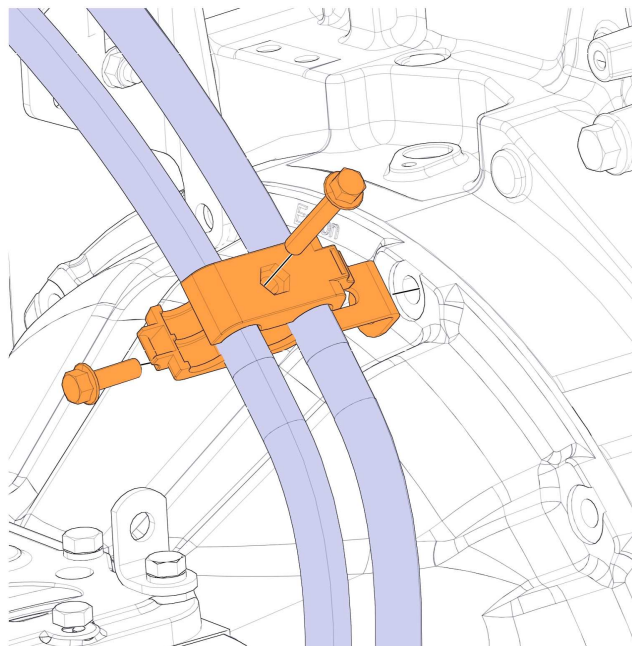

W3077595

- 11 Remove the bolt and install the bracket and clamp 1 hole clockwise from original location on clutch housing.  
Torque to 68 Nm (50 ft lbs).

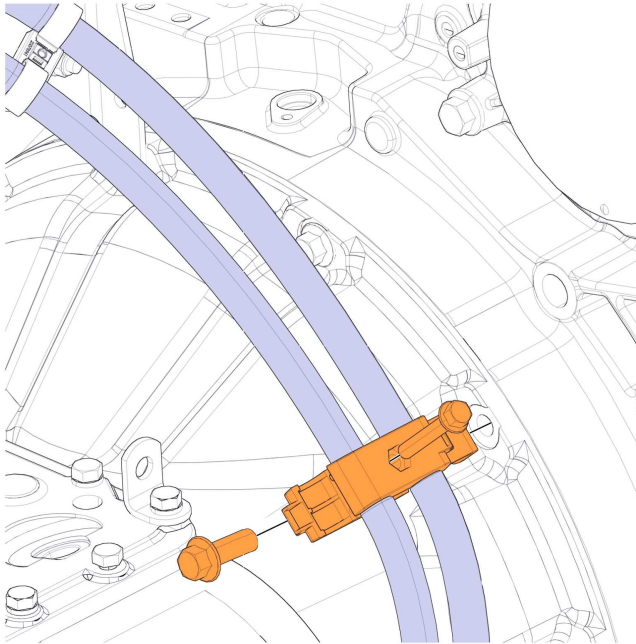

W3077612

- 12 Lay the battery cables in place at the clutch housing.

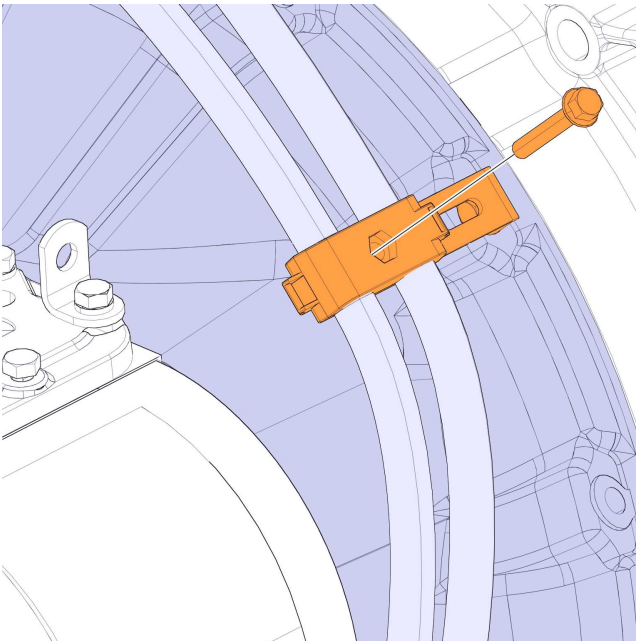

W3077963

- 13 Torque the new clamps to 8.1 Nm (6 ft lb) and the old existing clamps to 6.8 Nm (5 ft lb).
- 14 Install cable ties as shown and or as needed to keep cables from touching or rubbing other objects.

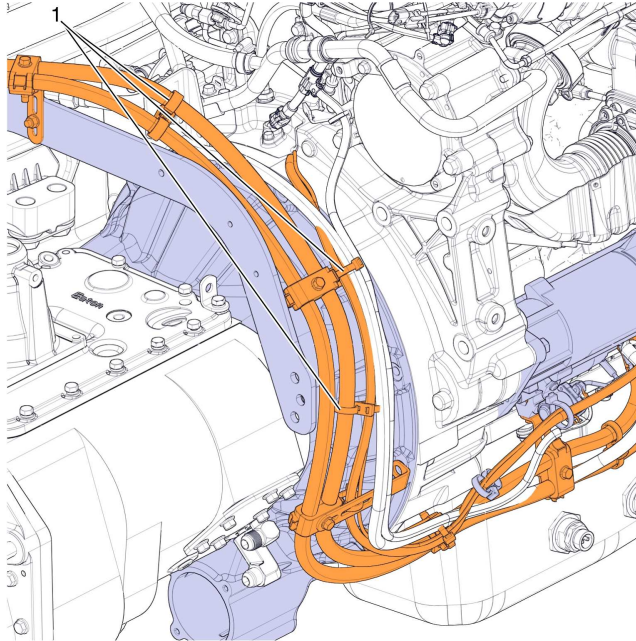

W3077594

1. Cable Ties

- 15 Install the center floor pan.
- 16 Install the center floor mat.
- 17 Install the shifter boot, airlines and knob.  
**Note:** Less than a perfect flush fit for the boot seal is considered unacceptable and will possibly cause exhaust gases or other unwanted fumes to leak into the cab area. Make certain the seal is fitting properly inside and outside the cab.  
**Note:** Check the seal is properly seated above and below the cab floor by inspecting inside and underside of cab.
- 18 Install driver's seat and attachments.
- 19 Connect batteries.
- 20 Start vehicle and air up the system. Ensure all electrical and pneumatic components work as they should.

**Note:** To signify that the campaign has been completed, using a permanent-type marker (such as a Sharpie®) write the campaign number (PI0802) and completion date in the spaces provided on the Campaign Completion label located inside the cab as shown in the illustration below. If a label is not already affixed inside the cab, apply a label (part No. TS897) and supply the information as required. Campaign Completion labels are available in packs of 50 and can be ordered by faxing a completed BR313 to Pacesetters Business Services at 610-264- 9465.

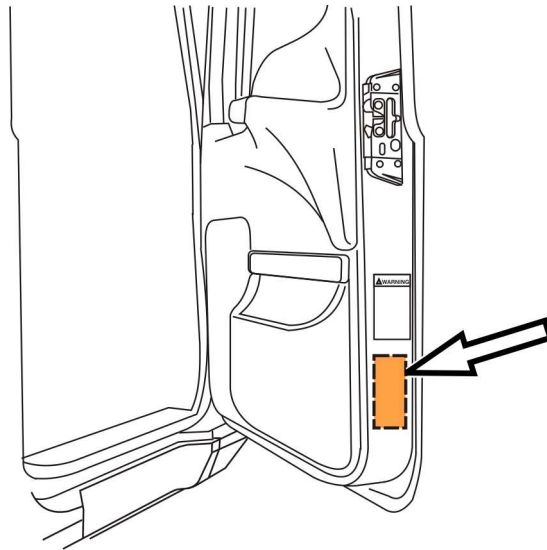

W8034103

**Reimbursement**

<b>This repair is covered by an authorized Service Program. Reimbursement is obtained through the normal claim handling process.</b>	
<b>Claim Type (used only when uploading from the Dealer Bus. Sys.)</b>	B
<b>Recall Status</b>	
Vehicle inspected, repair not required	1- Inspected OK
Vehicle repaired per instruction	2- Modified per instruction
<b>Labor Code</b>	
Primary Labor Code (includes inspection and take charge)	7211E-ZP-96 1.6 hours
<b>Causal Part</b>	21658909
<b>Authorization Number</b>	PI0802
<b>Expiration Date</b>	05-DEC-13