

This Field Service Bulletin replaces bulletin, "Grade Gripper Solenoid, Replacement", (USA65270) PV729-FSB593-013_M, dated (5.2014).

Date	Group	No.	Release	Page
10.2014	593	013	02	1(13)

Grade Gripper Solenoid, Replacement
CHU, CXU, GU, TD

FSB 593-013, Grade Gripper Solenoid, Replacement

(October 2014)

On some MACK CHU, CXU, GU, and TD truck models built between 04/31/2008 and 05/12/2014, the solenoid valve for the grade gripper feature is prone to internal contamination in harsh environments. The internal contamination of the solenoid valve is caused by the build-up of grime, salt, road debris and other solid contaminants. In some cases, the build-up of solid contaminants caused the solenoid valve to malfunction. The malfunction causes the trailer brake circuit to maintain trailer brake pressure after a grade gripper event. Replacement of the existing solenoid valve, elbow, and the addition of a new vent will ensure proper functionality of the grade gripper feature.

Note: This bulletin does not apply to MACK Trucks Australia.

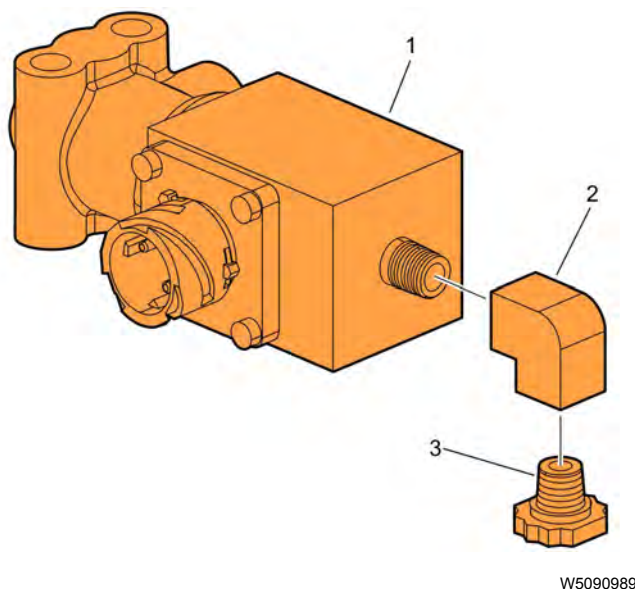

Required Parts

Grade Gripper Solenoid Replacement Parts			
Item	Description	Part Number	Qty
1	Solenoid Valve	21396762	1
2	Elbow	3082873	1
3	Vent	25164397	1

Repair Procedure

You must read and understand the precautions and guidelines in Service Information, group 5, "General Safety Practices, Brakes" before performing this procedure. If you are not properly trained and certified in this procedure, ask your supervisor for training before you perform it.

DANGER

Do not attempt to repair or service this vehicle without having sufficient training, the correct service literature and the proper tools. Failure to follow this could make the vehicle unsafe and lead to serious personal injury or death.

- 1 Park vehicle on a flat and level surface.
- 2 Apply the parking brake.
- 3 Place the transmission in neutral or park.
- 4 Install the wheel chocks.

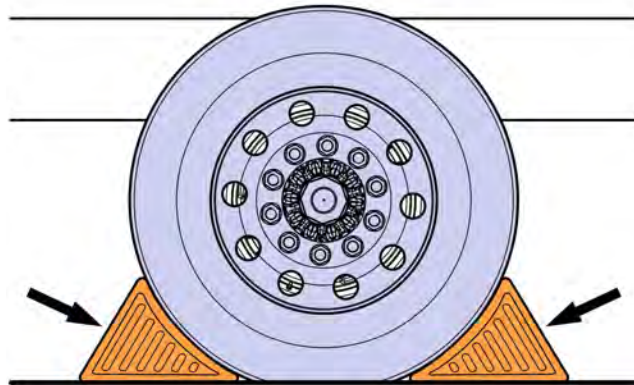

W7086748

- 5 Disconnect the cable from the battery's negative terminal.

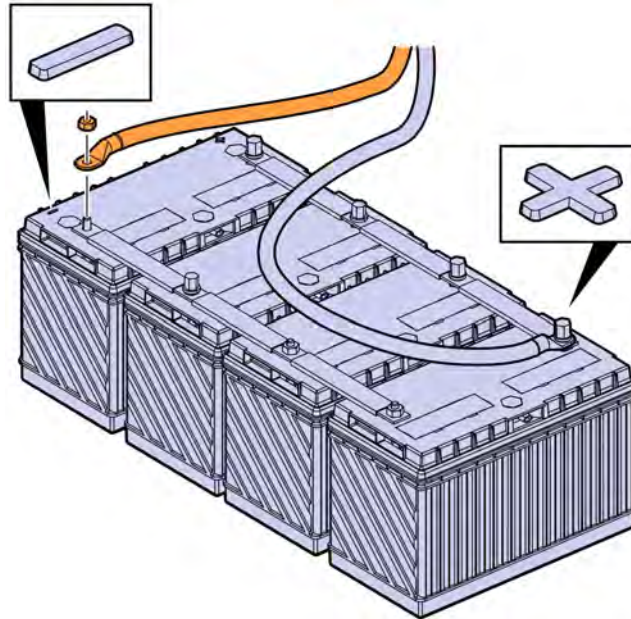

W3086747

- 6 If applicable, slide the fifth wheel to the rear most position to gain access to the solenoid valve.

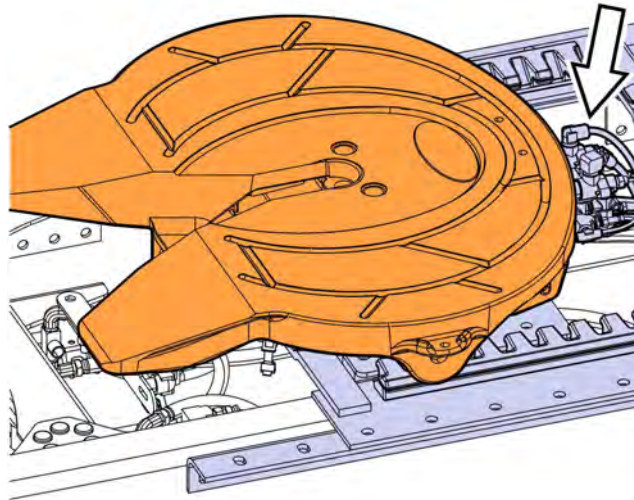

W9090990

7 Disconnect the harness from the solenoid.

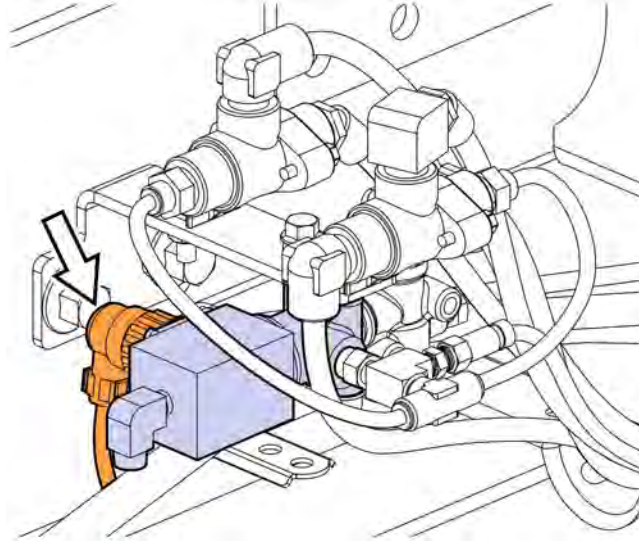

W5090991

8 Disconnect the air lines shown.

Note: Note the position of the air lines before removal.

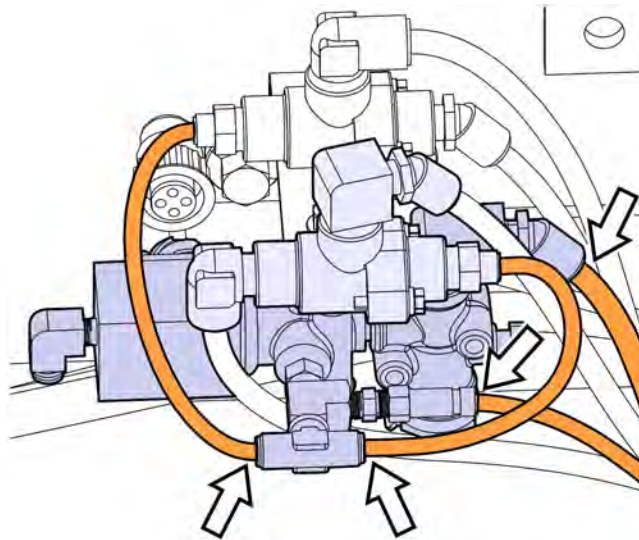

W5090993

9 Remove the solenoid valve assembly.

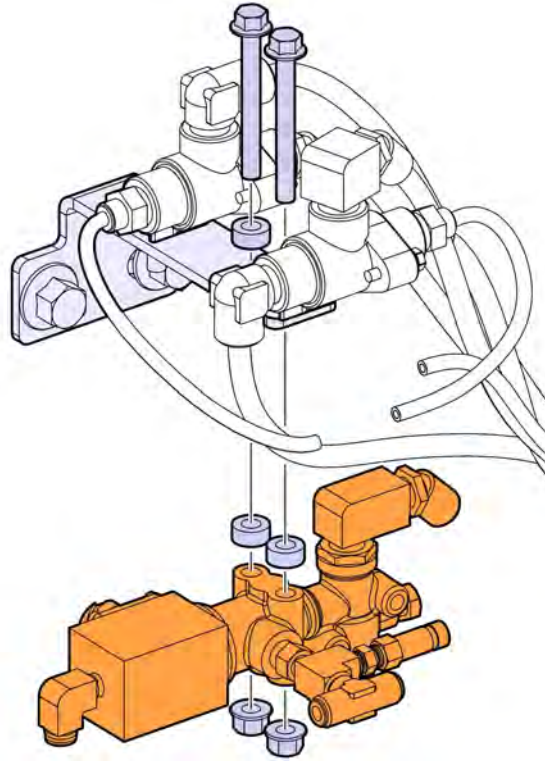

W5090994

10 Remove the fittings from the solenoid valve.

Note: Note the position of the fittings for installation.

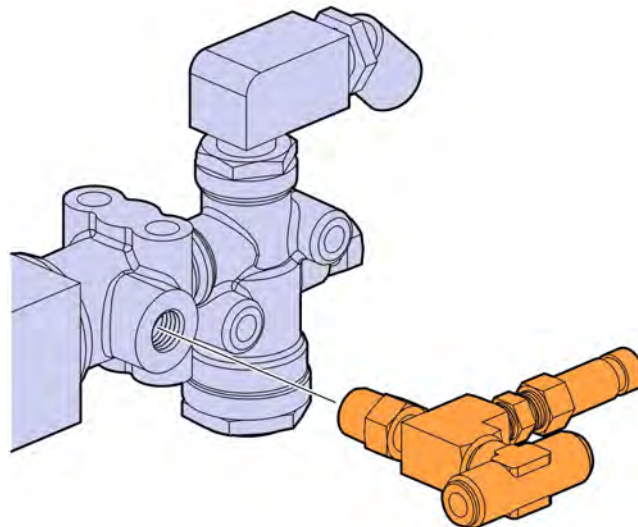

W5090995

11 Remove the elbow fitting from the solenoid valve.

Note: Note the position of the elbow fitting for installation.

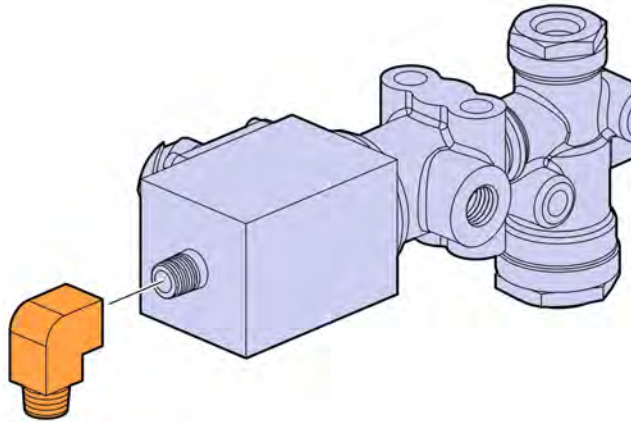

W5090996

12 Position and clamp the solenoid in a vise by the valve body as shown.

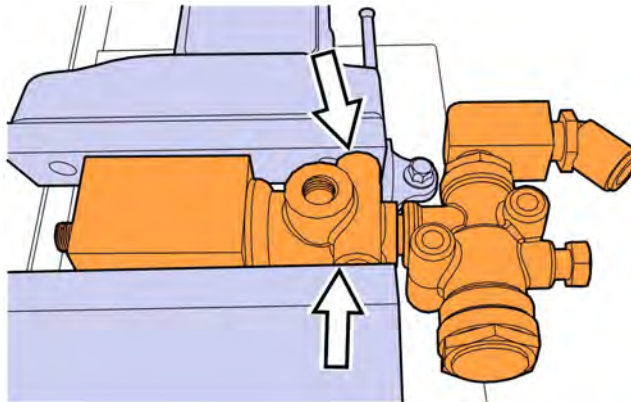

W5090997

13 Remove the valve (1) from the solenoid valve (2).

Note: Note the position of the valve (1) for later installation.



CAUTION

Removal of the union fitting (3) from the solenoid valve (2) will cause damage to the fitting.

Note: If the union fitting (3) is removed with the valve, clean and store both for installation.

Note: If the union fitting (3) is fixed in the solenoid valve after removal of the valve, discard the solenoid valve and the union fitting, then clean and store the valve for installation.

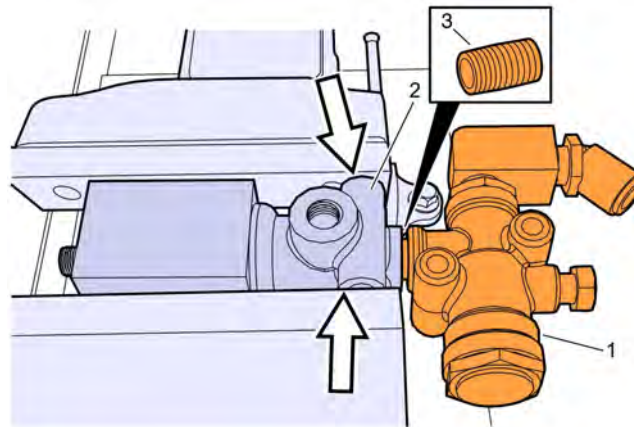

W5090998

14 Remove the existing solenoid from the vise.

15 Position and clamp the replacement solenoid in a vise by the valve body as shown.



CAUTION

To prevent damage to the solenoid valve, do not clamp the electrical portion of the solenoid.

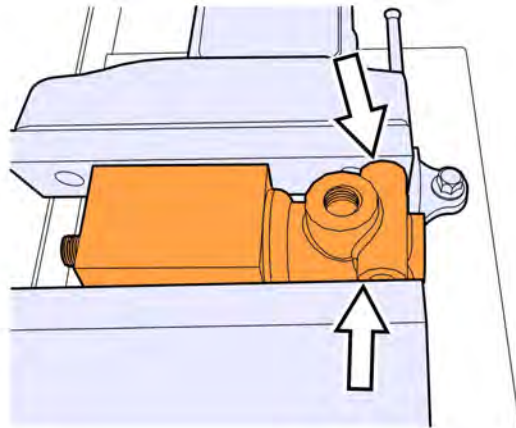

W5090999

16 Assemble the replacement solenoid valve (2), valve (1), and union fitting (3).

Note: Apply thread sealant to the fitting before assembly.

Note: if applicable, assemble a new union fitting (part number 25089731) and valve prior to assembly with the solenoid valve.

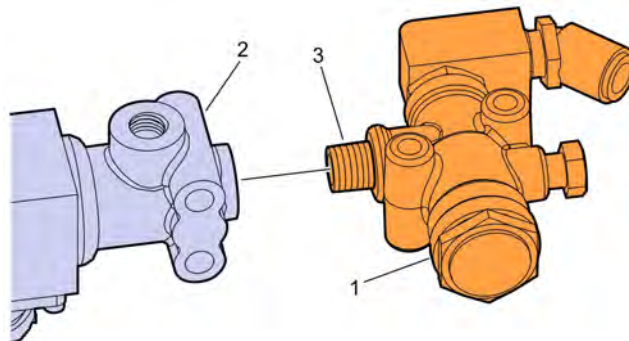

W5091000

- 17 Remove the replacement solenoid from the vise.
- 18 Install the replacement elbow fitting (part number 3082873) to the solenoid valve.

Note: Apply thread sealant to the solenoid before installing elbow fitting.

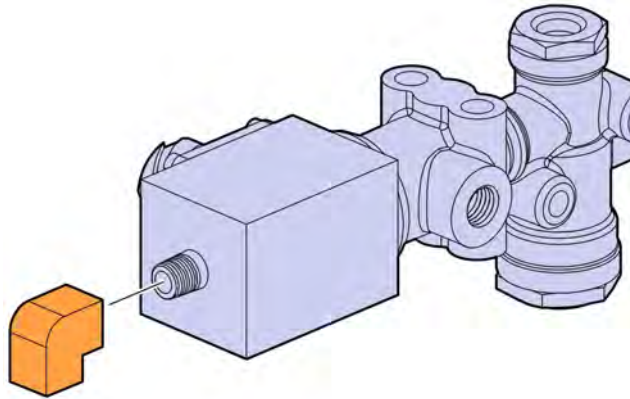

W5091001

- 19 Install the vent fitting (part number 25164397) on the elbow fitting.

Note: Ensure the inside and outside of the vent fitting is clean and free of any solid contaminants before installation.

Note: Apply thread sealant to the vent fitting before assembly.

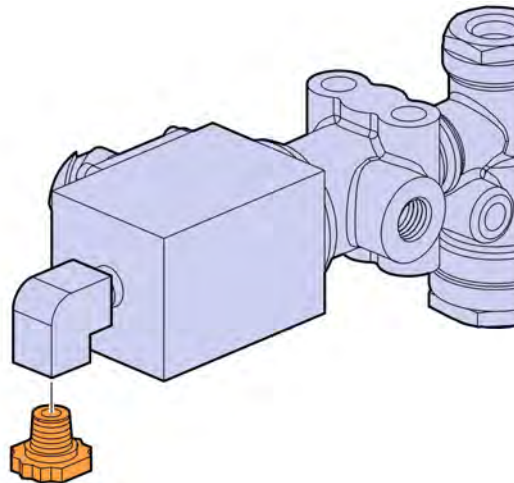

W5091002

20 Install the solenoid valve fittings as shown.

Note: Apply thread sealant to the fitting before assembly.

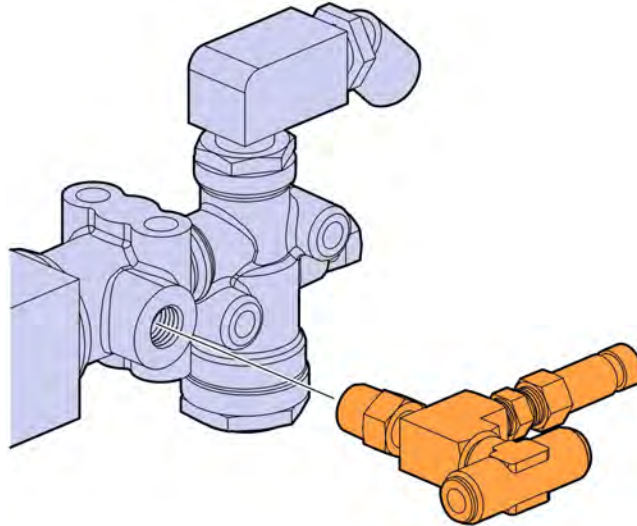

W5090995

21 Position the solenoid valve assembly.

22 Install the fasteners securing the solenoid valve assembly.

23 Tighten the fasteners to 24 ± 4 Nm (18 ± 3 ft-lb).

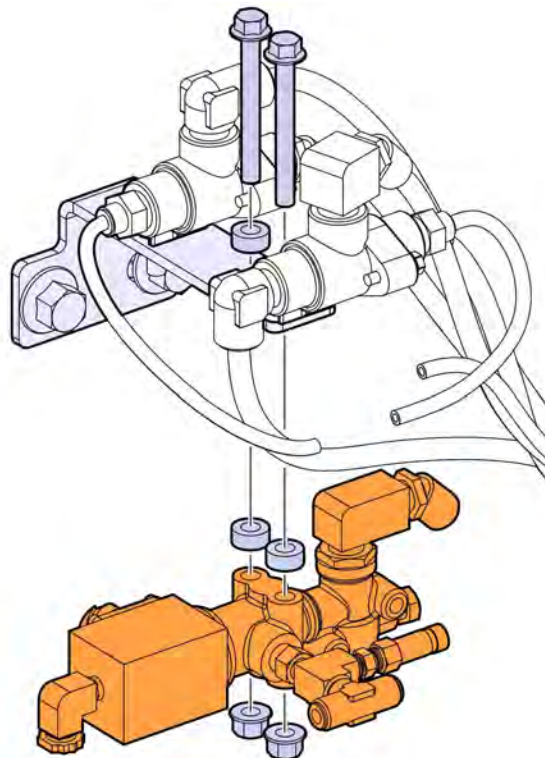

W5091003

24 Connect the air lines.

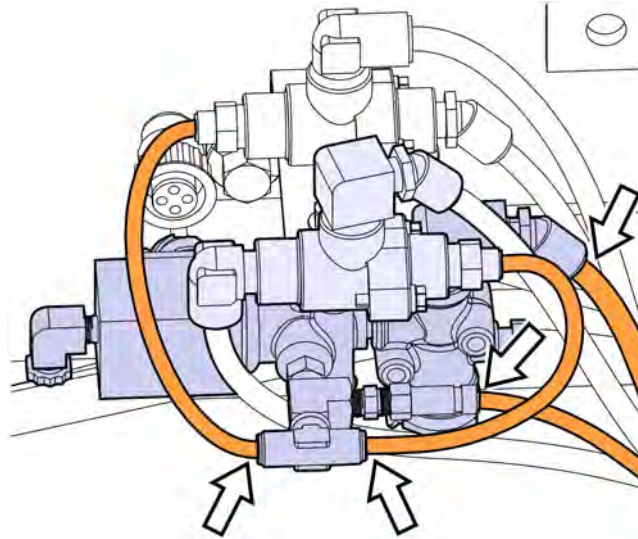

W5091004

25 Connect the harness.

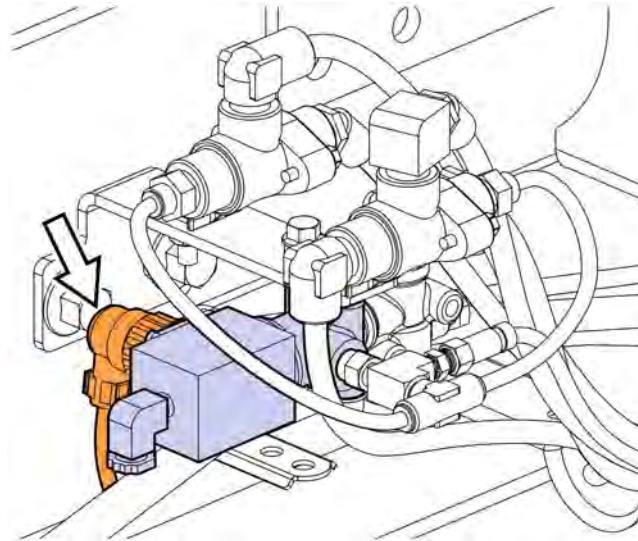

W5091005

26 If applicable, return the fifth wheel to it's original position.

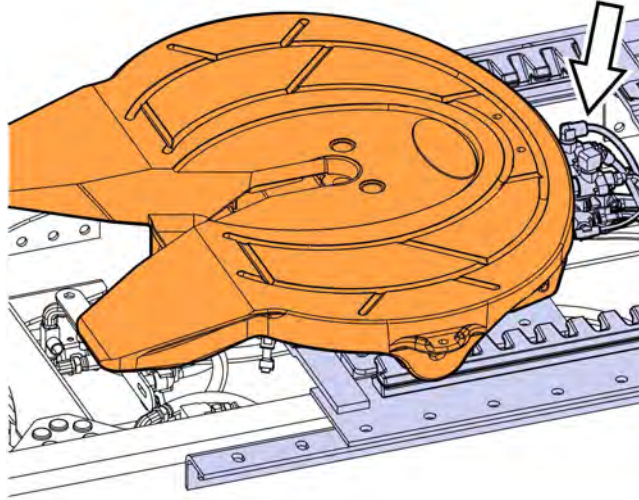

W9090990

27 Connect the battery cable to the negative (ground) terminal.

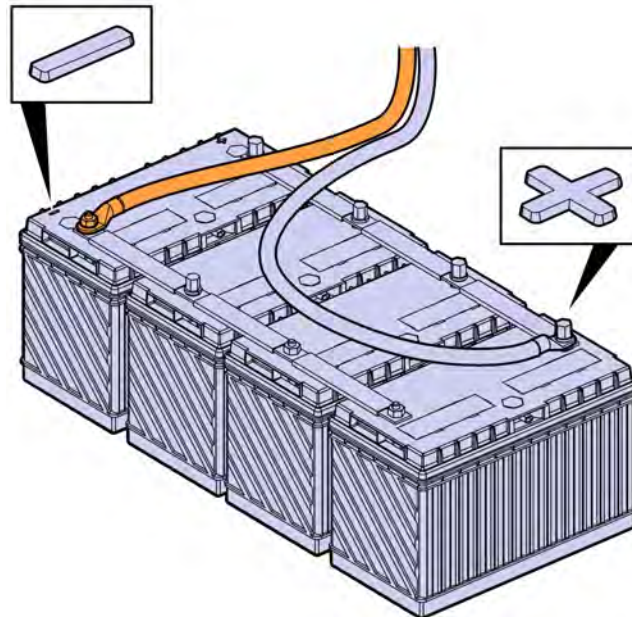

W3086758

28 Remove the wheel chocks.

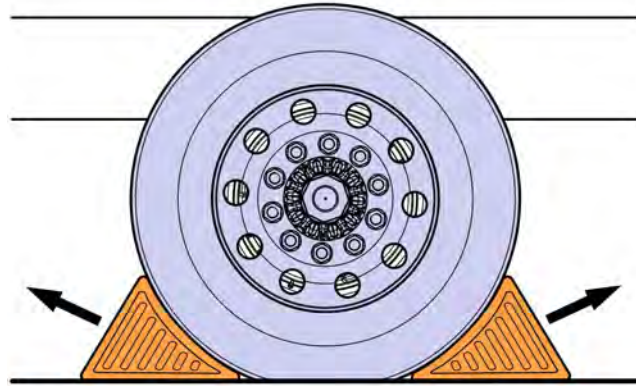

W7086759

Reimbursement

This repair may be eligible for reimbursement if a product failure was experienced within time and mileage limits of the applicable Warranty coverage. Reimbursement is obtained via the normal claim handling process.	UCHP Reimbursement	eWarranty Reimbursement
Claim Type (used only when uploading from the Dealer Bus. Sys.)	01	01
Labor Code		
Primary Labor Code	5939-03-09-02 0.4 hrs.	5332E-01-80 0.4 hrs.
Causal Part	21396762	21396762

MACK Trucks North America reserves the right to make any changes in design or to make additions to or upon its products without incurring any obligations to install the same on vehicles previously built.