



Date	Group	No.	Release	Page
10.2015	<b>722</b>	<b>005</b>	<b>01</b>	1(32)

Twin-Y Suspension, Trailing Blade,  
Replacement  
CHU, CXU, CSM, CMM  
(MACK Axles)

## **FSB 722-005, Twin Y Suspension, Trailing Blade, Replacement**

### **Mack Axles**

**(October 2015)**

Some MACK CHU, CXU, CSM, and CMM trucks built 06/13/2013 through 09/25/2015 and equipped with Twin-Y suspension may require replacement of the Twin-Y trailing blades with a more robust design. The new Twin-Y trailing blades have a new profile with a stronger material thickness of 7.0 mm (0.28 in). All four trailing blades will require replacement in this repair procedure. Follow the repair procedure outlined in this Field Service Bulletin (FSB) for replacement of the existing Twin-Y trailing blades with the newly designed trailing blades and hardware. See the tables on pages 2 and 3, for required parts.

This bulletin does apply to MACK Trucks Australia.

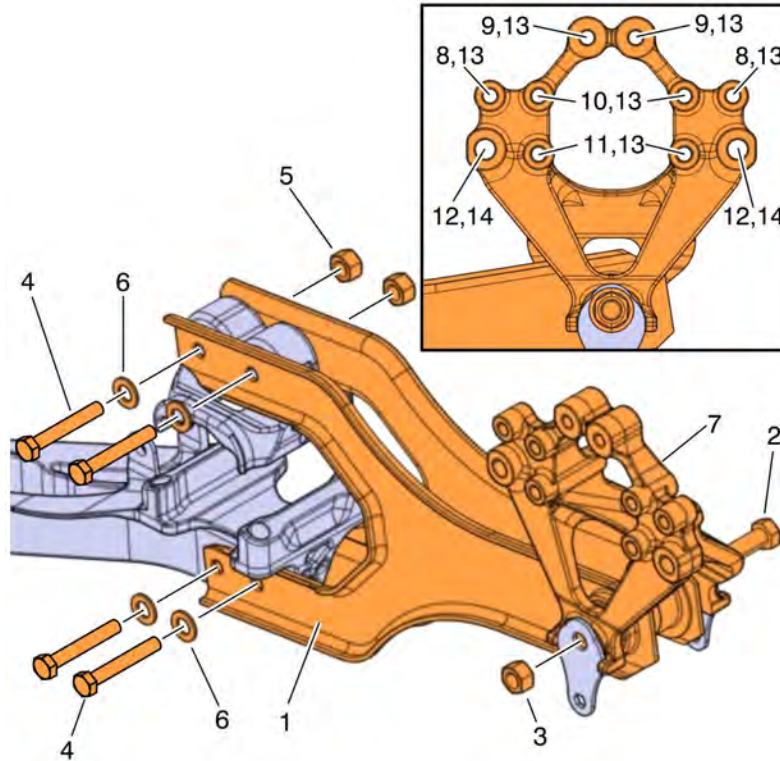

W7104594

## Required Parts

Twin-Y Suspension, Trailing Blade, Replacement Parts			
Item	Description	Part Number	Qty
1	Trailing Blade	22477420	4
2	Pivot bolt, M22 X220, Huck 360 Bolt	22496392	4
3	Pivot Bolt Collar, M22 X 26.4, Huck 360 Nut	22496430	4
4	Axle Seat Bolts, M18 X 110, Huck 360 Bolt	22356967	16
5	Axle Seat Bolt Collar, M18 X 21.6, Huck 360 Collar	22356966	16
6	Washer M19*34*3	60110294	16
7	Hanger Bracket	21684150	As Required
8	Hanger Bracket Bolt, 14 87-64	21475330	2 #
9	Hanger Bracket Bolt, 14 97-74	21638411	2 #
10	Hanger Bracket Bolt 14 107-84	21475333	2 #
11	Hanger Bracket Bolt 14 142-119	21710877	2 #

Twin-Y Suspension, Trailing Blade, Replacement Parts (Continued)			
Item	Description	Part Number	Qty
12	Hanger Bracket Bolt 20 115-68	22438561	2 #
13	Hanger Bracket Bolt Collar 14*21	21475706	8 #
14	Hanger Bracket Bolt Collar 20*29	22410765	2 #
15	Bendix Cast Brake Cam Tube (Right Side)	85147138	2 ##
16	Bendix Stamped Brake Cam Tube (Right Side)	85147140	2 ##
17	Meritor Cast Brake Cam Tube (Right Side)	85146886	2 ##
18	Meritor Stamped Brake Cam Tube (Right Side)	85146887	2 ##

**Note:** # These quantities listed in this table are per hanger bracket.

**Note:** ## One brake cam tube is required per axle (**Right Side Only**). Determine the number of axles, which manufacturer, and type of brake cam tube you are going to replace.

## Decommissioning the Truck for Repair

You must read and understand the precautions and guidelines in Service Information, group 70, "General Safety Practices, Frame, Springs, Shocks & Wheels" before performing this procedure. If you are not properly trained and certified in this procedure, ask your supervisor for training before you perform it.

**NOTE:** Information is subject to change without notice. Illustrations are used for reference only and can differ slightly from the actual vehicle being serviced. However, key components addressed in this information are represented as accurately as possible.

- 1 Park the vehicle on a flat and level surface.
- 2 Apply the parking brake.
- 3 Place the transmission in neutral or park.
- 4 Install the wheel chocks.

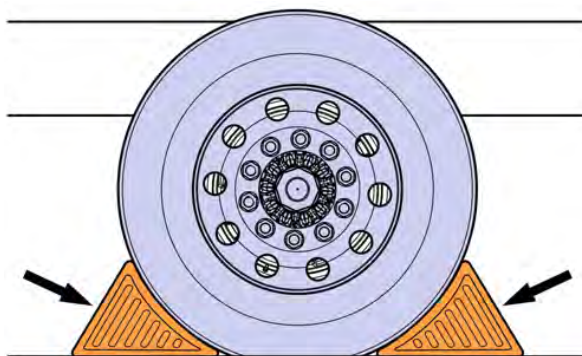

- 5 Disconnect the cable from the battery's negative terminal.

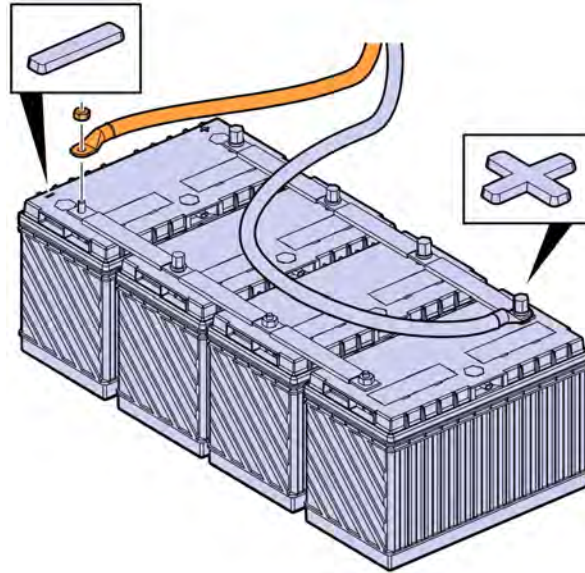

W3086747

## Twin-Y Suspension, Trailing Blade, Replacement Procedure

- 1 Following safe lifting procedures, lift and support both the frame and axle housings.
- 2 Remove the wheel nuts.
- 3 Remove the wheels.

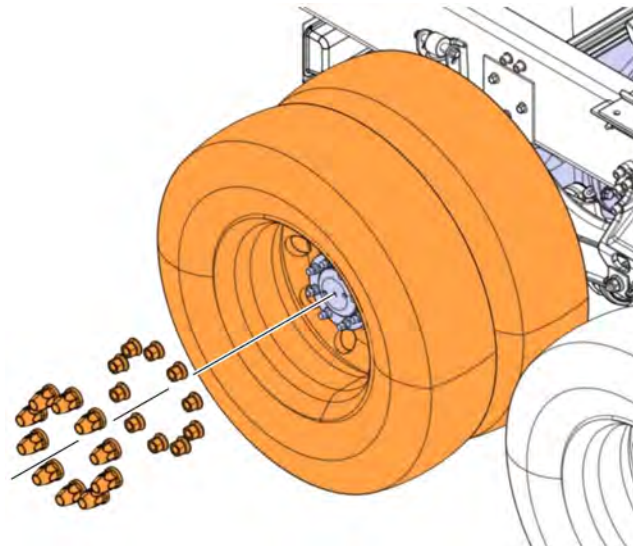

W7104595

- 4 Release the park brake.
- 5 Back off the brakes (slack adjusters).

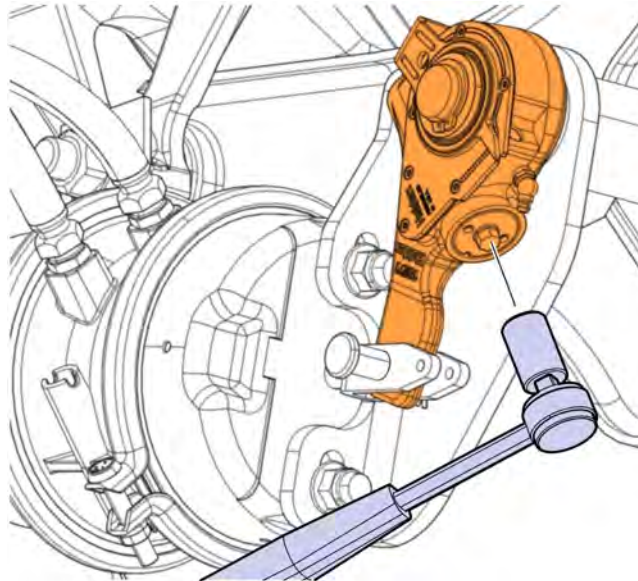

W7104596

- 6 Cage the brake chambers.

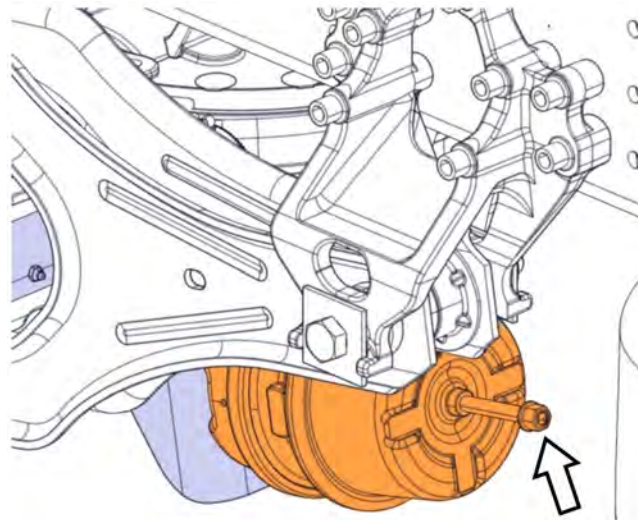

W7104597



7 Remove the brake drums.

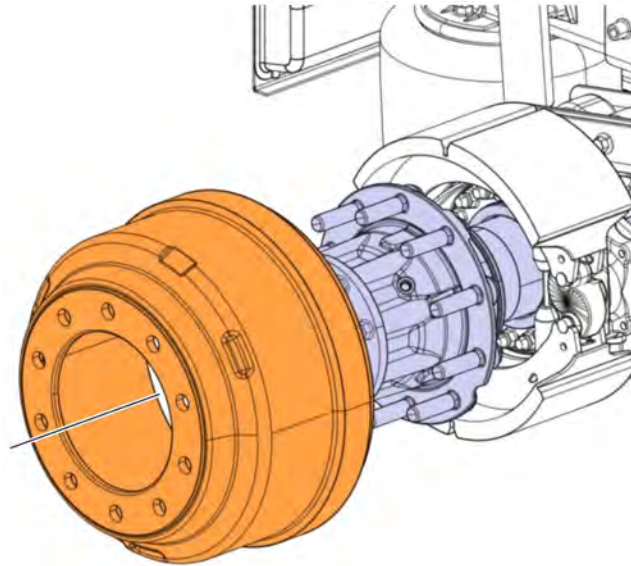

W7104598

8 Remove the brake linings, brake springs and rollers.

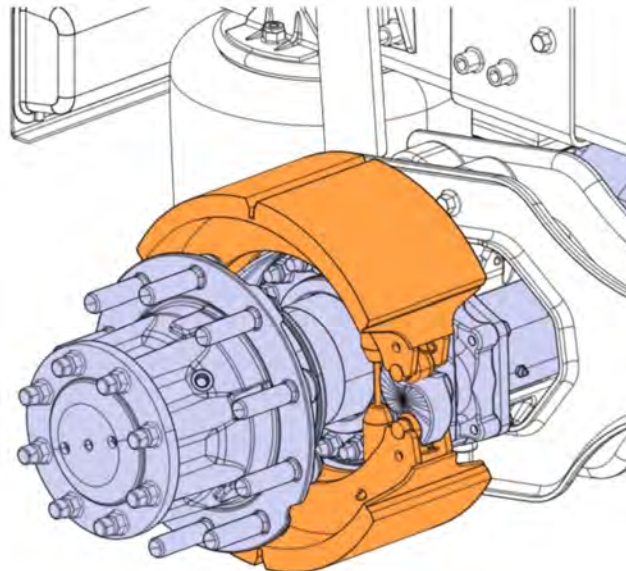

W7104599

- 9 Loosen the pivot bolt (1) securing the trailing blade to the frame hanger bracket (left side).

**Note:** Before loosening the pivot bolt (left side), mark the cam adjustment washers (2) for re-installation.

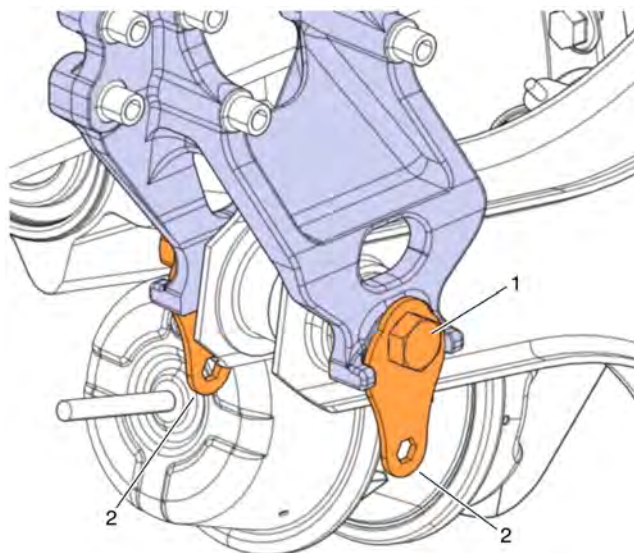

W7104600

- 10 Loosen the pivot bolt and collar securing the trailing blade to the frame hanger bracket (right Side).

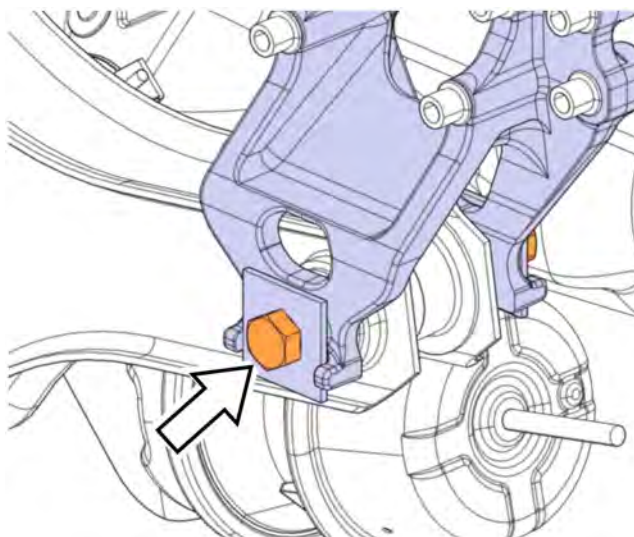

W7104601

11 Remove the fasteners securing the trailing blade to the top plate and spring seat.

**Note:** Discard the fasteners. Do not reuse.

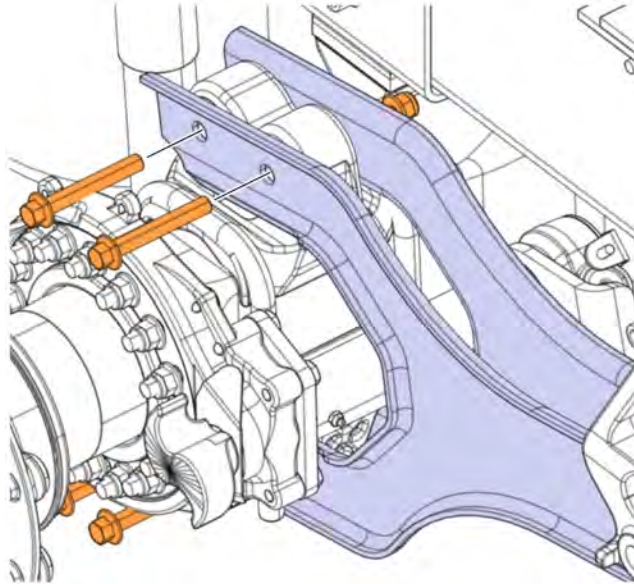

W7104602

12 Remove the loosened pivot bolt collars (1), pivot bolts (2) and cam adjustment washers at frame hanger brackets (left side).

**Note:** Discard the pivot bolt collars and pivot bolts. Do not reuse.

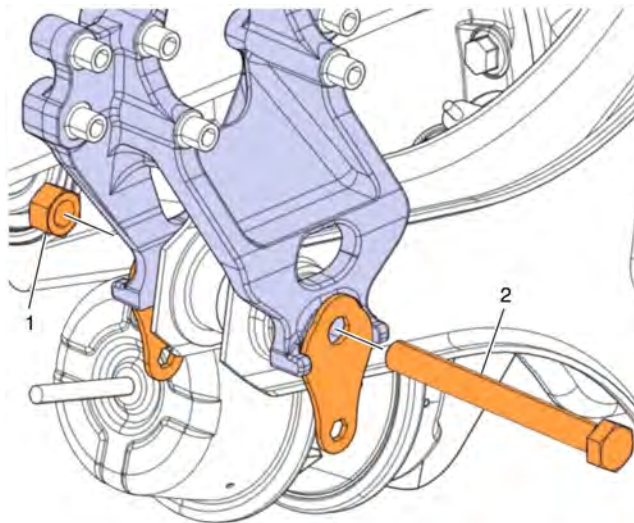

W7104603



13 Remove the pivot bolt (1), collar and washers (2) at the frame hanger bracket (right side).

**Note:** Discard the pivot bolt collars and pivot bolts. Do not reuse.

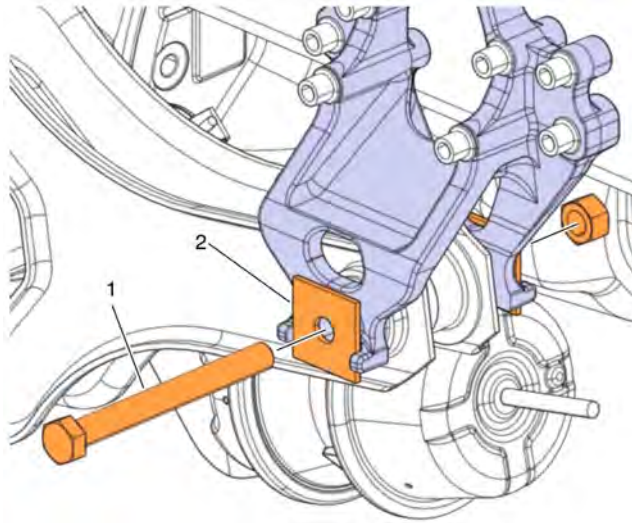

W7104604

14 With assistance, remove the trailing blades from the axle and frame hanger brackets.

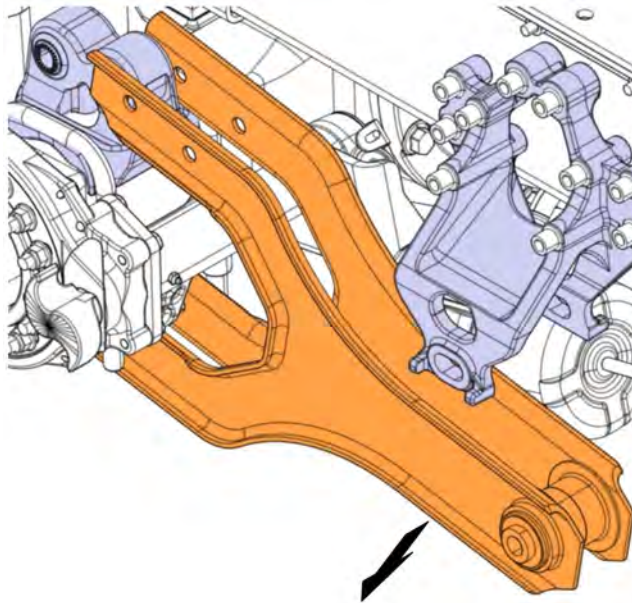

W7104605

- 15 Inspect the bushings in the top plate, spring seat and trailing blade for wear or damage and replace as needed.

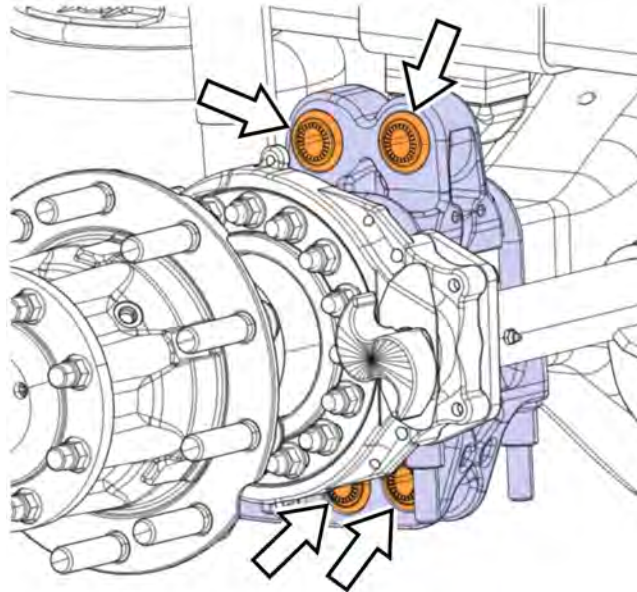

W7104606

- 16 Inspect all frame hanger brackets for wear on the inside mating surface and check for the trailing blade bushing wear. If significant wear is present, the frame hanger bracket and/or brackets must be replaced. Failure to do so will result in poor alignment and/or loosening fasteners.

**Note:** if needed, refer to 7114-03-02-08 (Trailing Blade, Hanger Bracket, Replacement) for trailing blade hanger bracket replacement procedures.

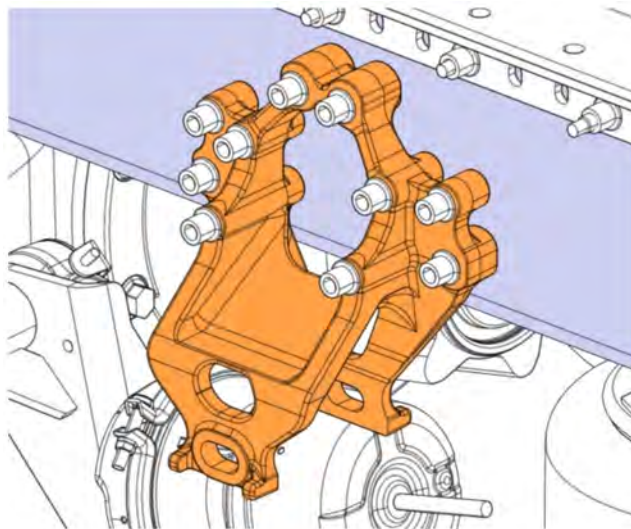

W7104607

17 Remove the cotter pin and the clevis pin securing the brake slack adjuster to brake chamber clevis.

**Note:** Discard the old cotter pin. Do not reuse.

**Note:** Replacement of the brake cam tube is required on the **RIGHT SIDE** of the truck only.

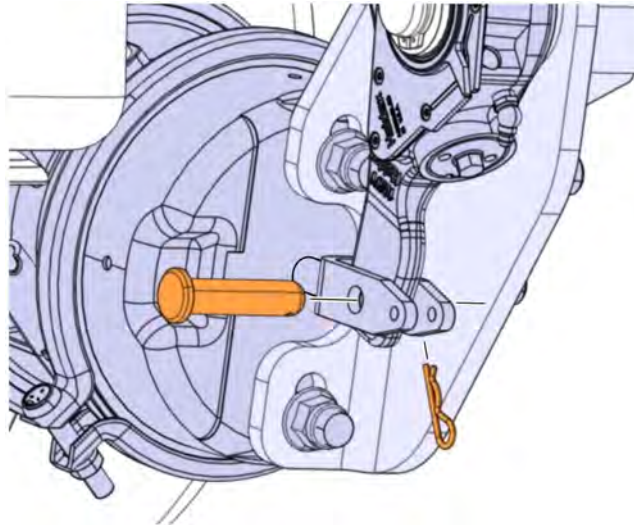

W7107436

18 Remove the snap ring and shims securing the brake slack adjuster to the brake cam shaft.

**Note:** Record the orientation of the snap ring and shims for installation purposes.

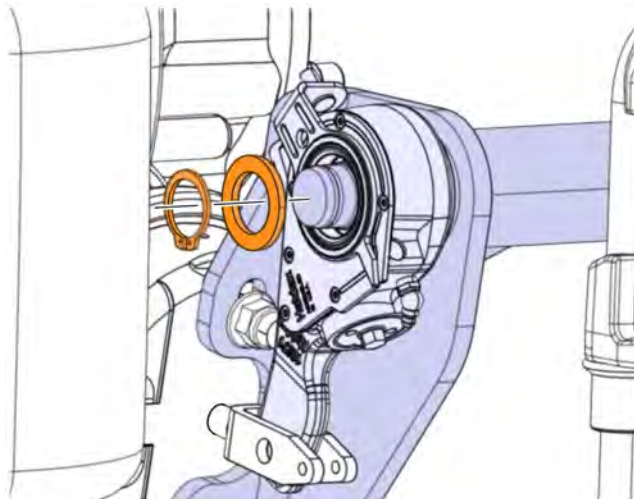

W7107437

19 Remove the fastener (1) securing the brake slack adjuster to the bracket (2).

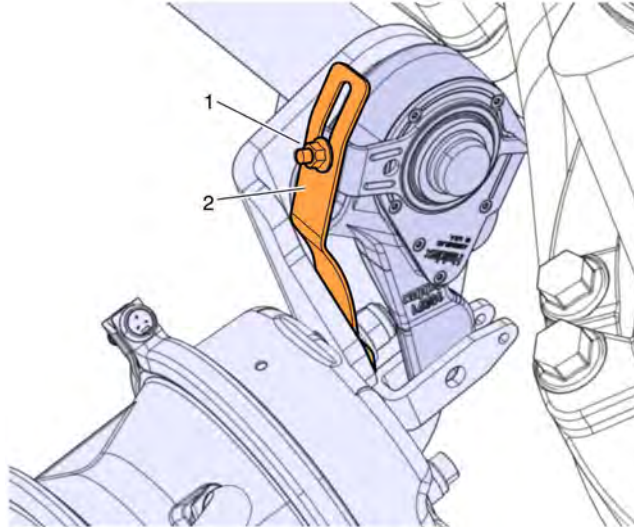

W7107676

20 Rotate the brake slack adjuster until it is clear of the brake chamber clevis as shown in the figure below.

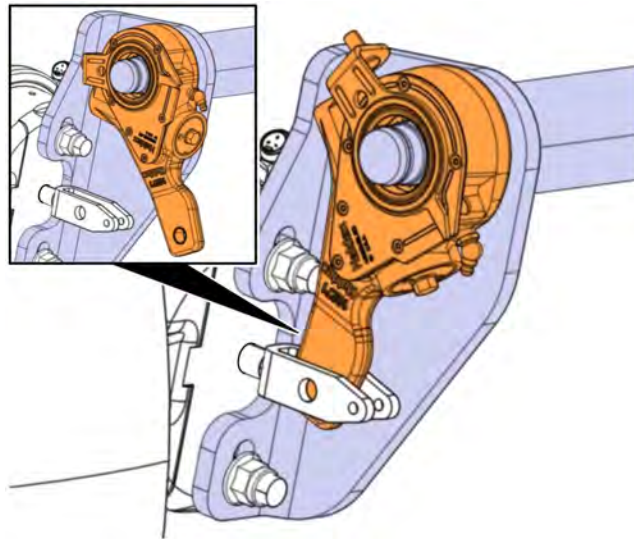

W7107438



21 Remove the brake slack adjuster and any spacers from the brake cam shaft.

**Note:** Record the orientation of the brake slack adjuster and the spacer for installation purposes.

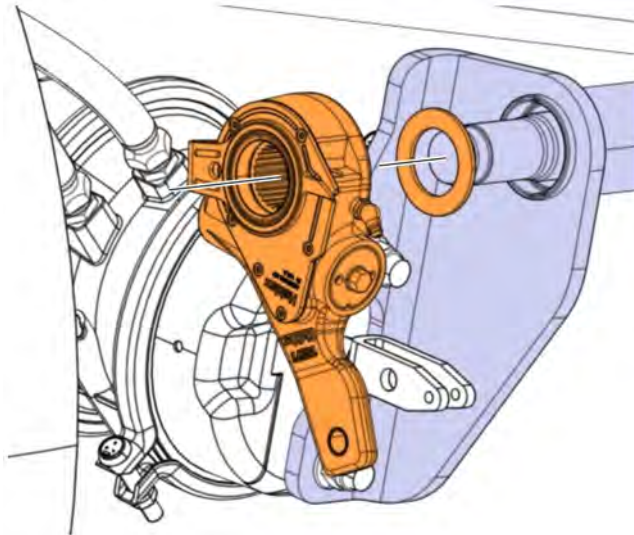

W7107439

22 Remove the fasteners securing the brake chamber to brake cam tube bracket.

23 Remove the brake chamber from the brake cam tube bracket, position the brake chamber away from the brake cam tube bracket.

**Note:** Using a lift or similar platform, support the brake chamber until installation.

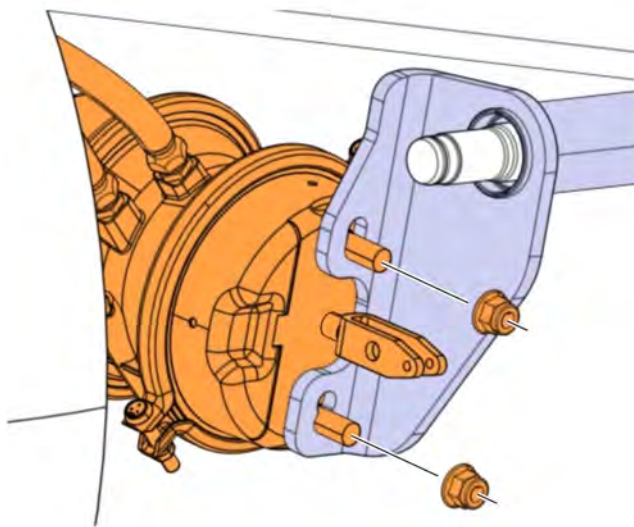

W7107440



24 Remove the fasteners and U-Bolt securing the brake cam tube to the top plate.

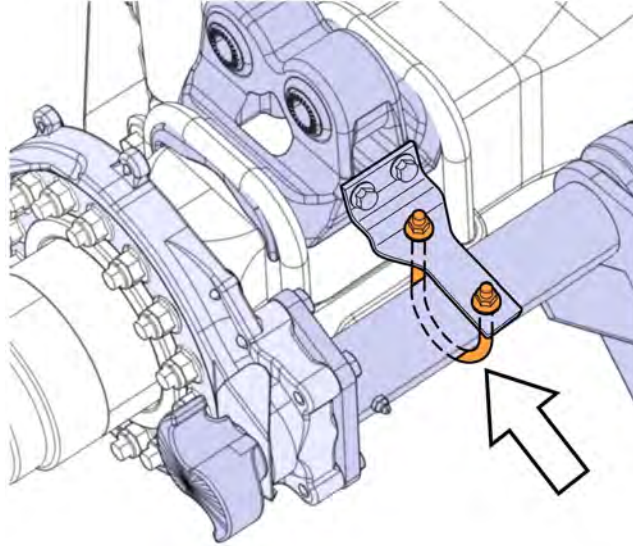

W7107677

25 Remove the four fasteners securing the brake cam tube to the brake spider bracket.

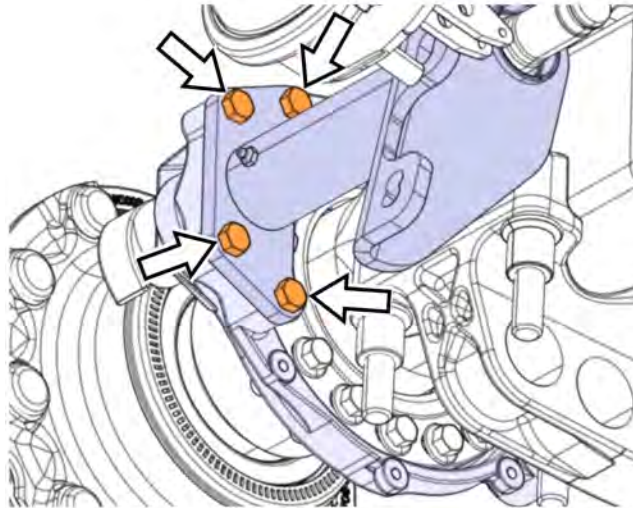

W7107441

26 Pull the S-Cam shaft outward to allow clearance for removal of the brake cam tube.

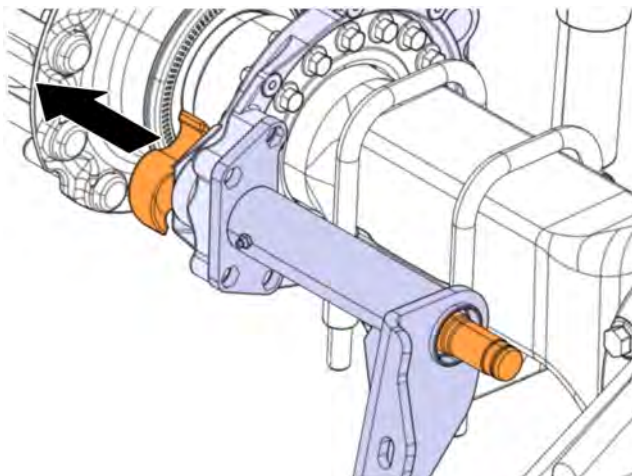

W7107442

27 Remove the brake cam tube from the brake spider bracket.

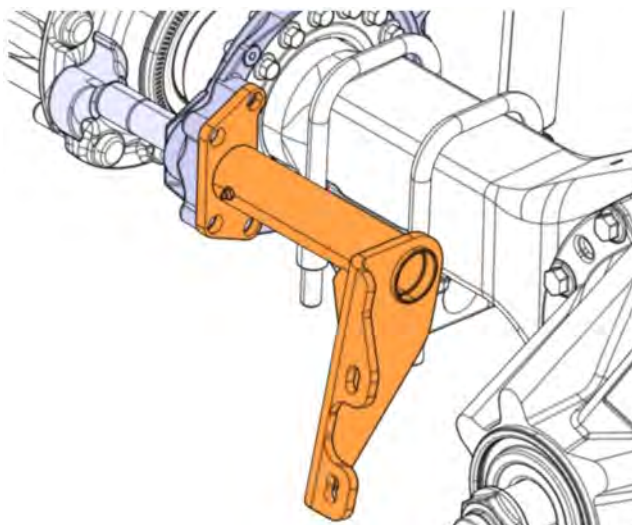

W7107443

28 After removal of the brake cam tube, Inspect the S-Cam shaft for damage to the splines such as cracks, deformation, and excessive wear. Check the S-Cam shaft head for cracking or flat spots.

**Note:** Replace any damaged brake S-Cam shafts before installation of the replacement brake cam tube.

29 position the replacement brake cam tube over the S-Cam shaft and on the brake spider bracket.

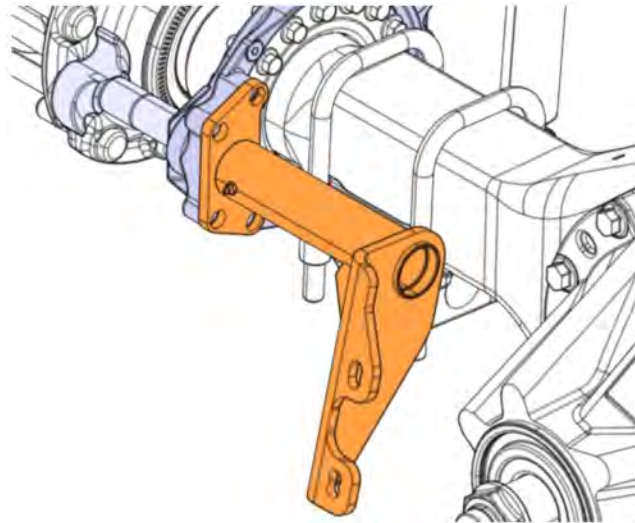

W7107443

30 Push the S-Cam shaft inward as shown in the figure below.

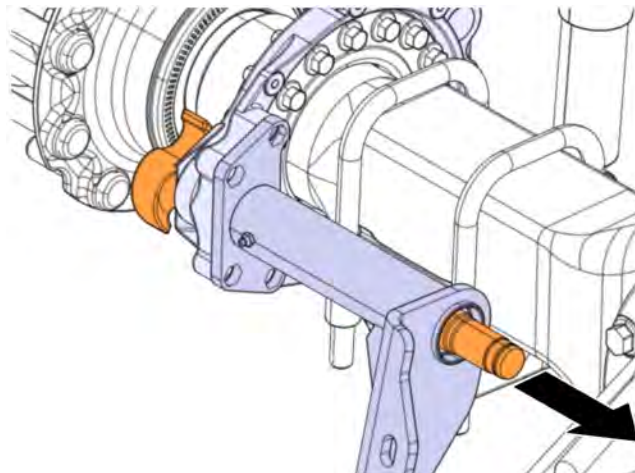

W7107444

- 31 Install the four fasteners securing the brake cam tube to the brake spider bracket.
- 32 Tighten the fasteners to  $60 \pm 10$  Nm ( $44 \pm 7$  ft-lb)

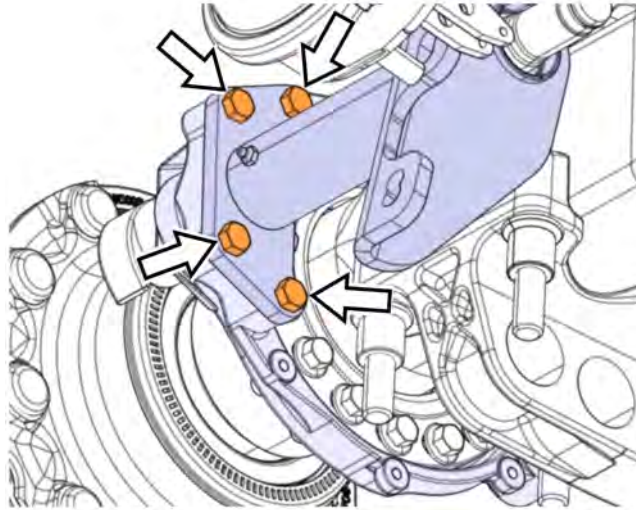

W7107441

- 33 Install the fasteners and U-Bolt securing the brake cam tube to the top plate.

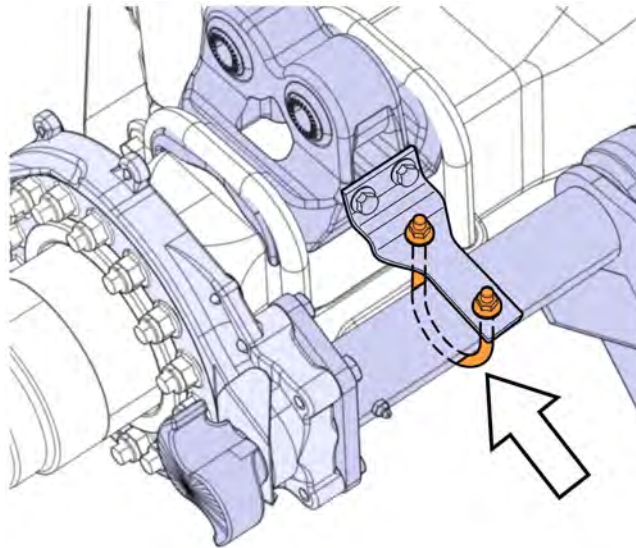

W7107677



- 34 Position the brake chamber on brake cam tube bracket.
- 35 Install the fasteners securing the brake chamber.
- 36 Initially tighten the fasteners to 80–100 Nm (59 - 75 ft-lb).
- 37 Then, tighten the fasteners to 180 – 210 Nm (133 – 155 ft-lb).

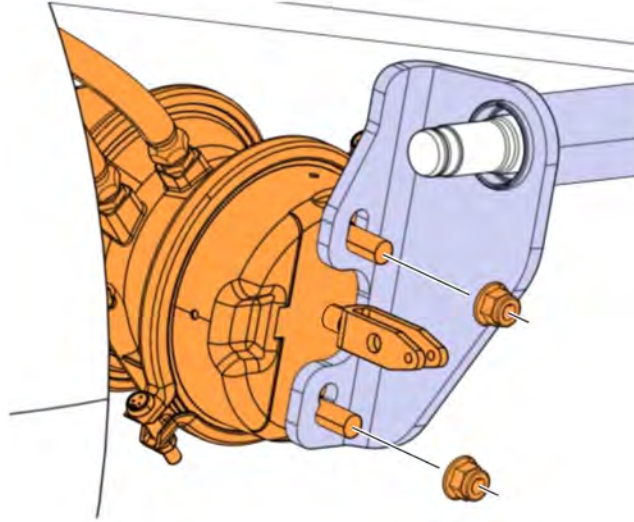

W7107440

- 38 Position the brake slack adjuster and any spacers on the brake cam shaft.

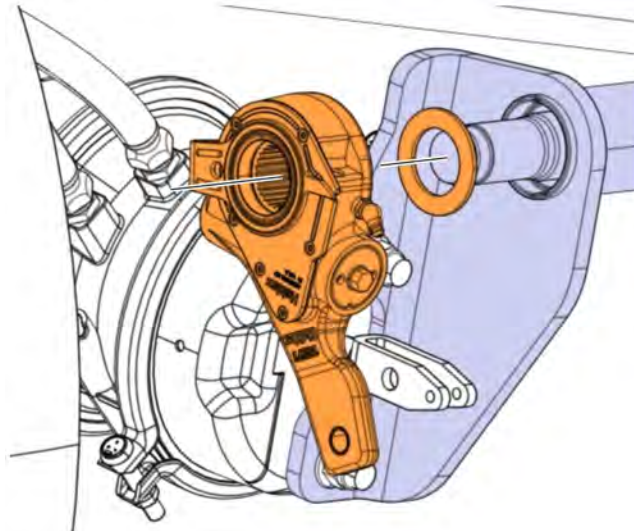

W7107439



39 Rotate and position the brake slack adjuster in the brake chamber clevis as shown in the figure below.

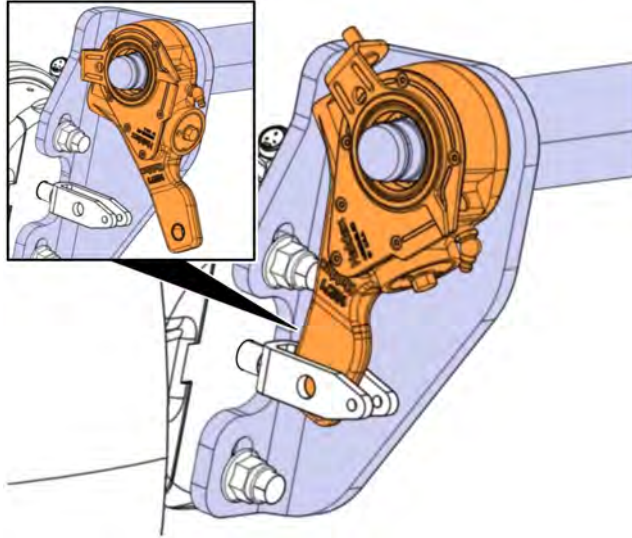

W7107438

40 Install the snap ring and shims securing the brake slack adjuster to the brake cam shaft.

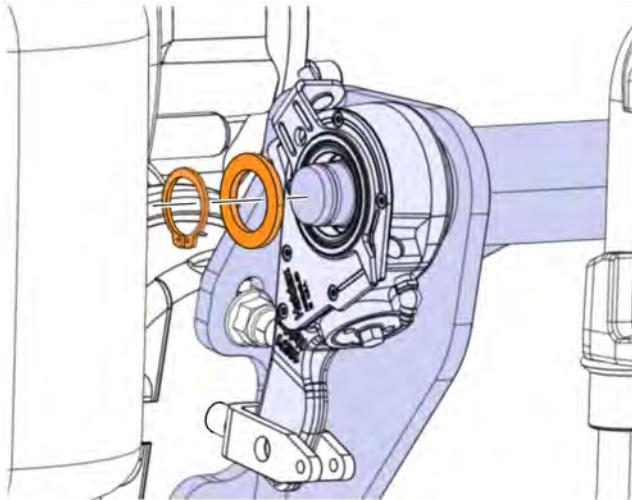

W7107437

41 Install the fastener (1) securing the brake slack adjuster to the bracket (2).

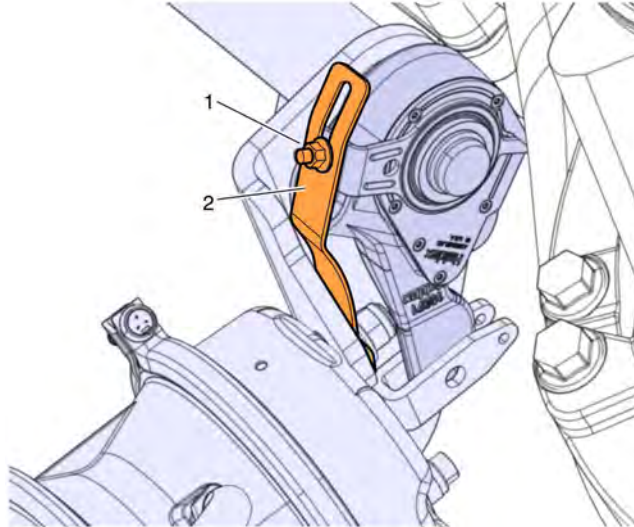

W7107676

42 Install the clevis pin and new cotter pin securing the brake slack adjuster to brake chamber clevis.

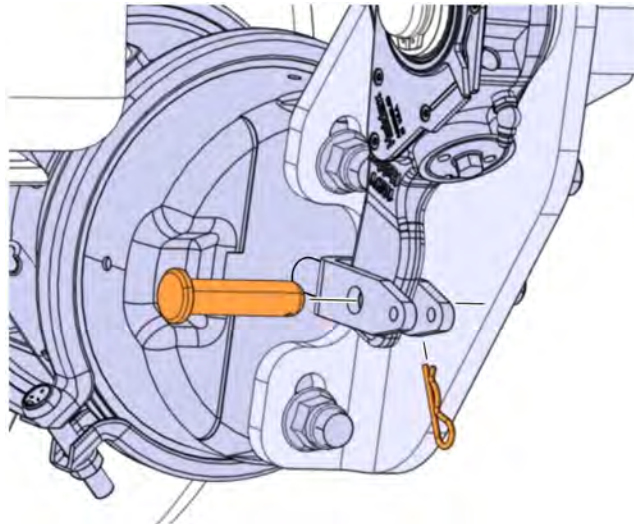

W7107436

43 Lubricate the brake cam tube at the grease fitting shown in the figure below.

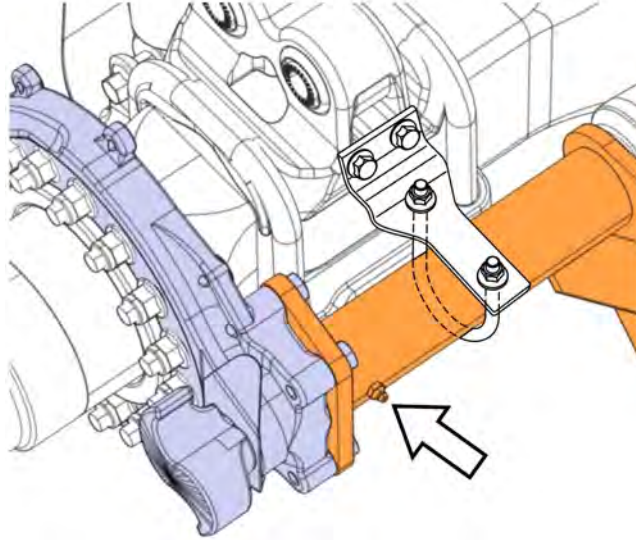

W7107678

44 With assistance, position the replacement trailing blade onto the axle. Install the fasteners securing the trailing blade.

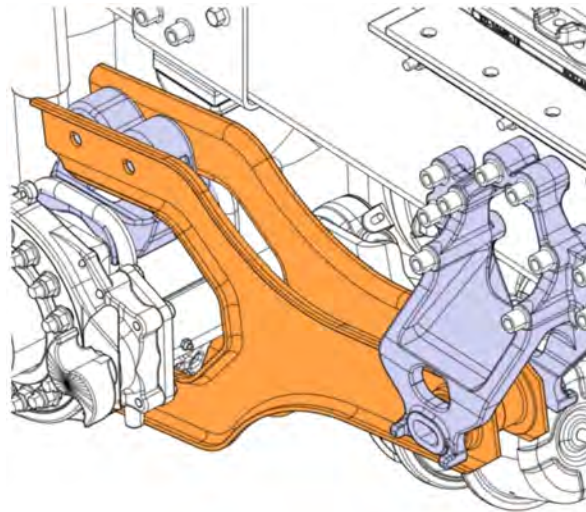

W7104608

45 Install the fasteners securing the trailing blade.

**Note:** Install the M19 Washers (part number 60110294) before installing the trailing arm bolts.

46 Tighten the fasteners securing the trailing blade to the axle to  $440 \pm 40$  Nm ( $325 \pm 30$  ft-lb).

**Note:** Wait one minute after tightening the fasteners, then tighten them to  $440 \pm 40$  Nm ( $325 \pm 30$  ft-lb) again.

**Note:** After the nuts (part number 22356966) are finally tightened, **DO NOT** back the nuts off of the bolts. If the nuts are backed off of the bolts, remove them, discard and install new ones. These nuts are for one time use only.

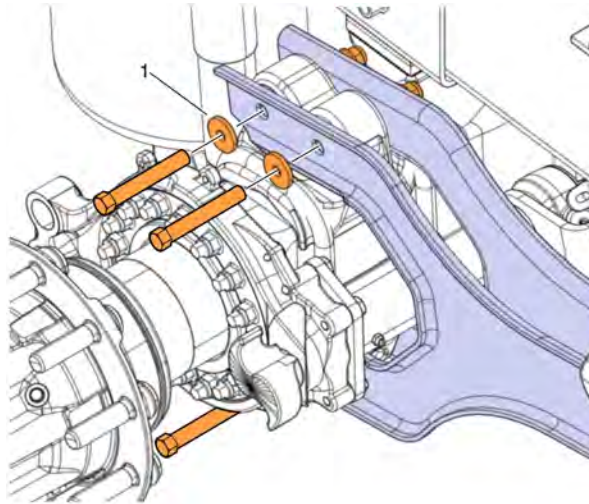

W7104609



47 Position and loosely attach the opposite end of the trailing blade onto the frame hanger bracket with the pivot bolts (1), cam adjustment washer (3) (left-hand side), spacer washers (4) (right-hand side) and pivot bolt collars (2).

**Note:** Do not tighten the fasteners at the frame bracket until the vehicle is at the correct ride height.

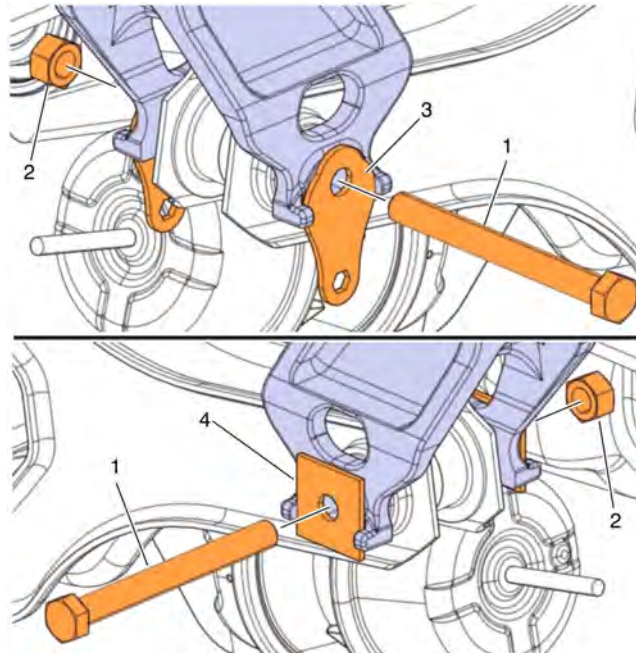

W7104610

48 Using new brake springs and rollers, install the brake linings.

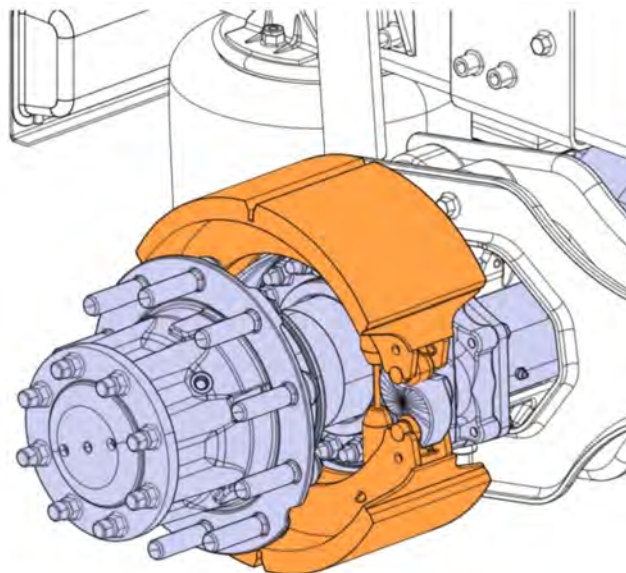

W7104599



49 Install the brake drums.

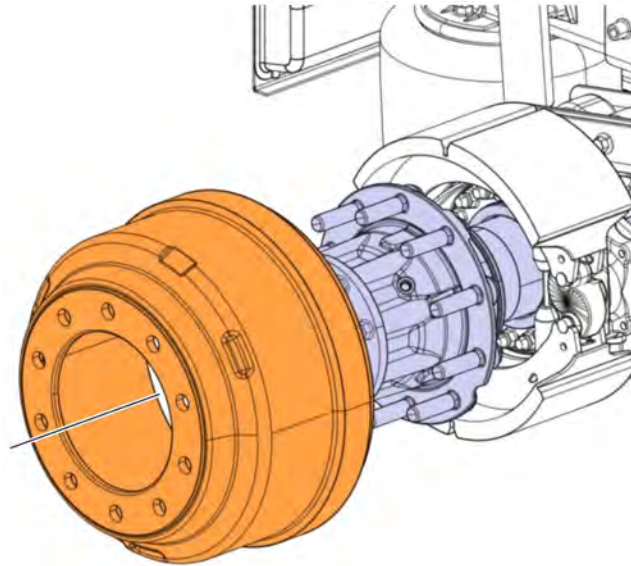

W7104598

50 Install the wheels.

51 Install the wheel nuts securing the wheels.

52 Tighten the wheel nuts to  $645 \pm 35$  Nm ( $475 \pm 25$  ft-lb).

**Note:** After the truck is lowered and the park brake is set, tighten the wheel nuts again to specification.

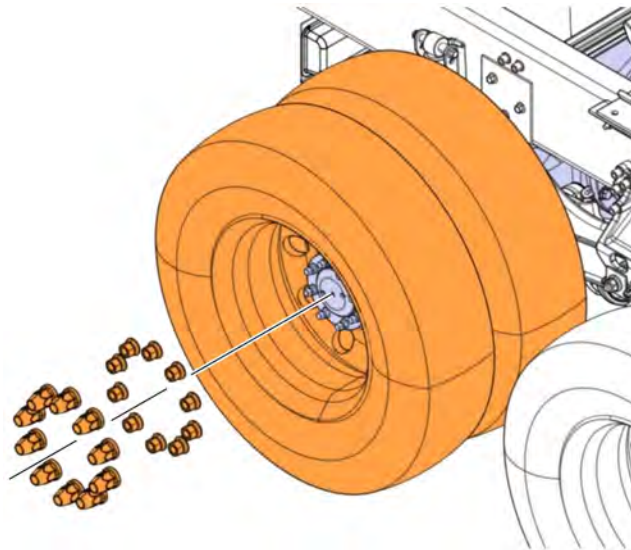

W7104595

53 Connect the battery cable to the negative (ground) terminal.

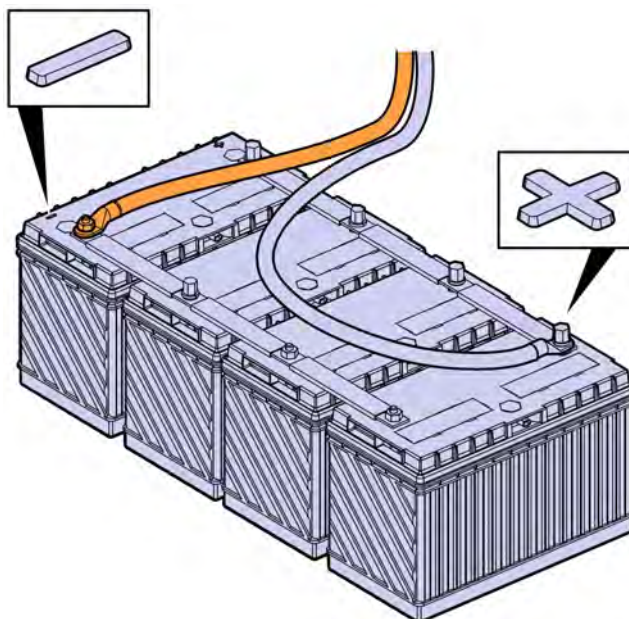

W3086758

54 Remove the wheel chocks.

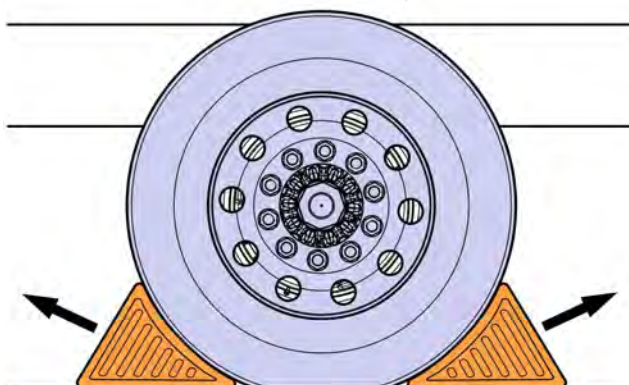

W7086759

55 Start the engine and fill the air system with air until the proper operating pressure of 120 psi (8 kPa) is obtained. The proper operating will ensure the brakes can be adjusted properly. Once the proper operating pressure is reached, stop the engine and check for air leaks.

**Note:** Ensure the park brake is released before adjusting the brakes.

56 Uncage the brake chambers.

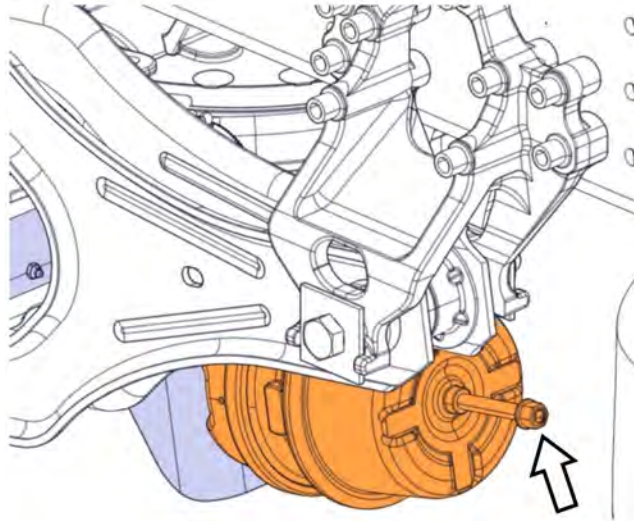

W7104597

57 Adjust the brakes as recommended per slack adjuster manufacturer.

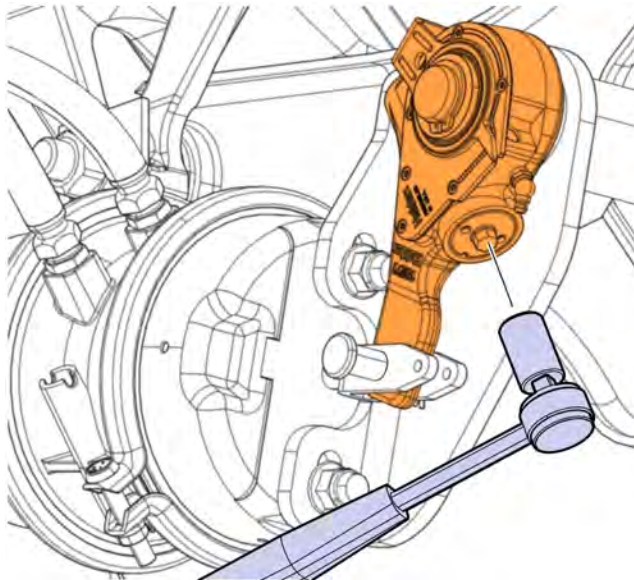

W7104596

- 58 Using a floor jack, lift the frame and the axle housing off of the jack stands.
- 59 Remove the jack stands and remove the jack from under the truck.
- 60 Check and adjust the ride height. Follow procedure outlined in the **Ride Height Adjustment and Calculations** section.

## Ride Height Adjustment and Calculations

- 1 Check all tires for proper inflation. If applicable, adjust tire air pressure to tire manufacturer's specifications.
- 2 Using the dash mounted rear suspension air dump switch, release the air in the rear air springs or disconnect the leveling rod (1) from the valve lever (2), and use the valve lever (2) to release pressure from the air springs.



### CAUTION

The suspension may drop quickly once pressure is released from the air springs.

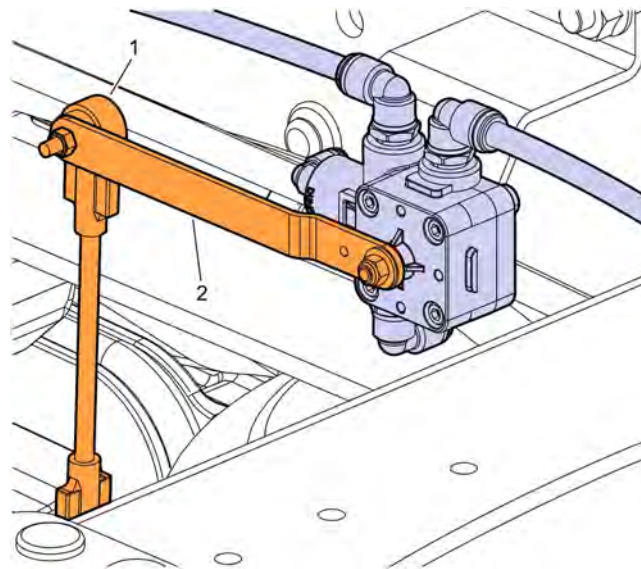

W7099902

- 3 Start the engine and allow the air system to reach the normal operating pressure of 827 kPa (120 psi).
- 4 Turn off the engine.
- 5 Inflate the rear air springs with air by using the dash mounted switch or reconnect the actuator rod to the load leveling valve lever.

**Note:** Ensure the air system is at a normal operating pressure of 827 kPa (120 psi).

- 6 Free and center all suspension joints by slowly moving the vehicle back and forth twice without using the brake.

**Note:** When coming to a complete stop, ensure the brakes (parking and service) are released.



7 Chock the front wheels.

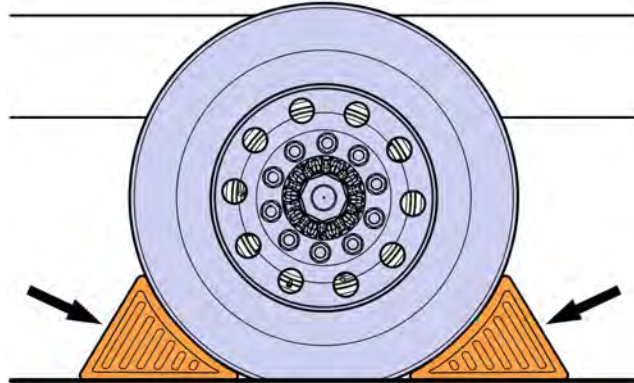

W7086748

8 Using a tape measure, measure and record the height of the frame rail.

**Note:** The ride height measurement is dependent on frame size.

9 Measure and record the distance from the floor to the center of the axle (Measurement – A).

10 Measure and record the distance from the bottom edge of the frame rail to the floor (Measurement – B).

11 Subtract measurement – A from measurement – B to calculate the ride height (A – B = ride height).

**Note:** Use the table below to determine if the truck is at the proper ride height.

Ride Height (Unloaded)		
Frame Height	Frame Type	Ride Height
266 mm (10.4 in)	RRH-200	210 ± 5 mm (8.27 ± 0.2 in)
300 mm (11.8 in)	RRH-180	193 ± 5 mm (7.6 ± 0.2 in)

- 12 Adjust the ride Height if needed. Slightly Loosen the fastener (1) securing the leveling valve to the frame rail.
- 13 Using the ride height adjustment tool (3) (part number J-44544), adjust the load leveling valve (2) until the ride height is within specification.

**Note:** The suspension ride height is adjusted by turning the load leveling valve **CLOCKWISE** (to raise) or **COUNTERCLOCKWISE** (to lower) the ride height.

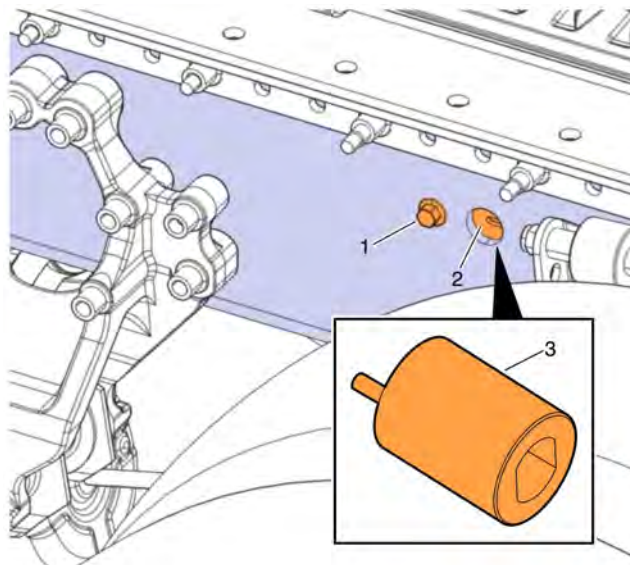

W7104611

- 14 Tighten the fastener (1) securing the load leveling valve (2) to the frame to  $175 \pm 40$  Nm ( $129 \pm 30$  lb-ft).

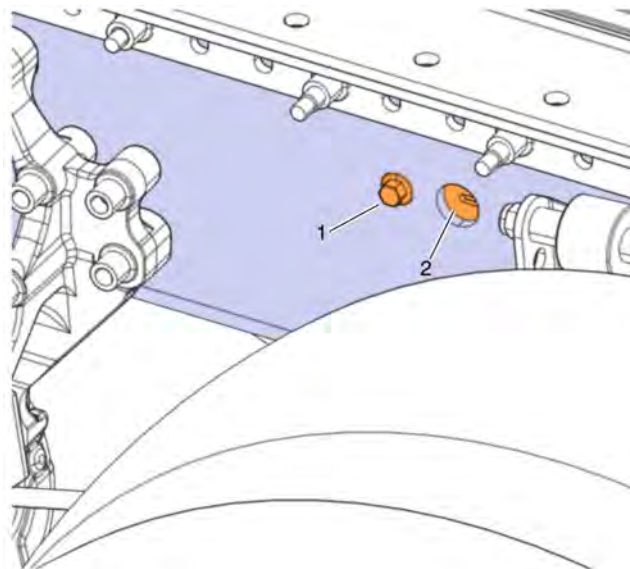

W7104656

- 15 Repeat steps 8 – 14 to validate the ride height and confirm the accuracy of the leveling valve adjustment.
- 16 Using the dash mounted rear suspension air dump switch, release the air in the rear air springs or disconnect the leveling rod (1) from the valve lever (2), and use the valve lever (2) to release pressure from the air springs.

 **CAUTION**

The suspension may drop quickly once pressure is released from the air springs.

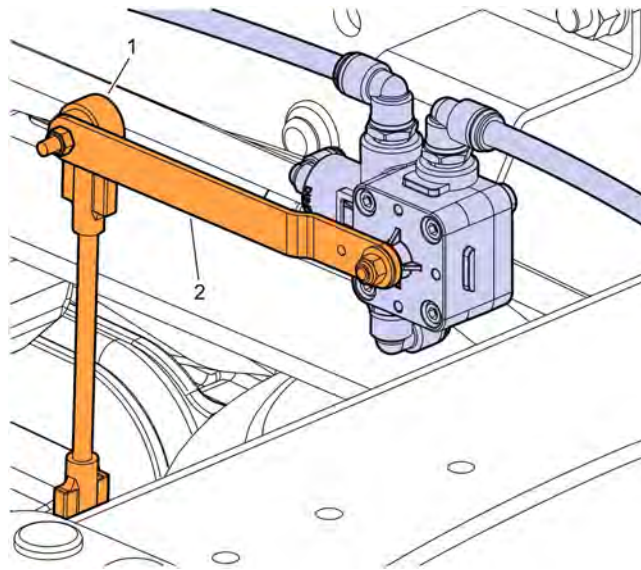

W7099902

- 17 If applicable, connect the suspension leveling rod (1) to the valve control lever (2).

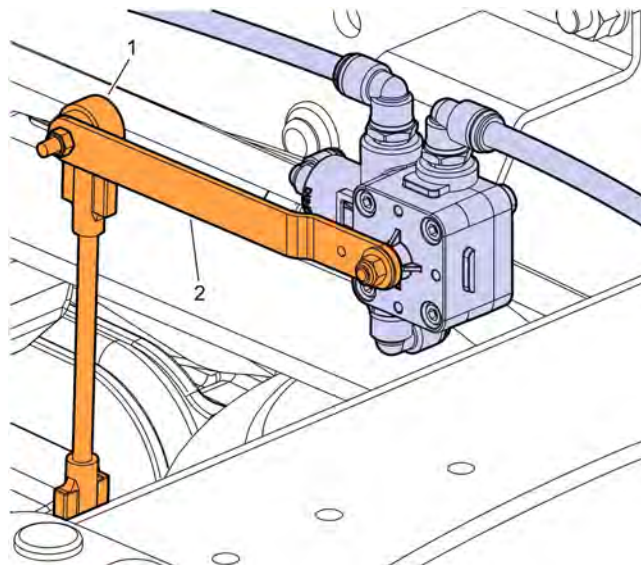

W7099902

18 Start the engine, build air pressure to the proper operating pressure, and stop engine.

19 Fill the rear air springs.

**Note:** Ensure the air pressure is at the proper operating pressure.

20 Using a tape measure, re-check the ride height.

**Note:** If the ride height is not within specifications, check the leveling valve and other suspension components for excessive wear or damage.

21 Apply the parking brake.

22 Using the previous cam alignment washer markings, Align the cam alignment washers (left side only).

**Note:** This should assist in getting close to the proper alignment.

23 With the truck at correct ride height, tighten fasteners at the frame hanger bracket to  $750 \pm 75$  Nm ( $550 \pm 55$  ft-lb).

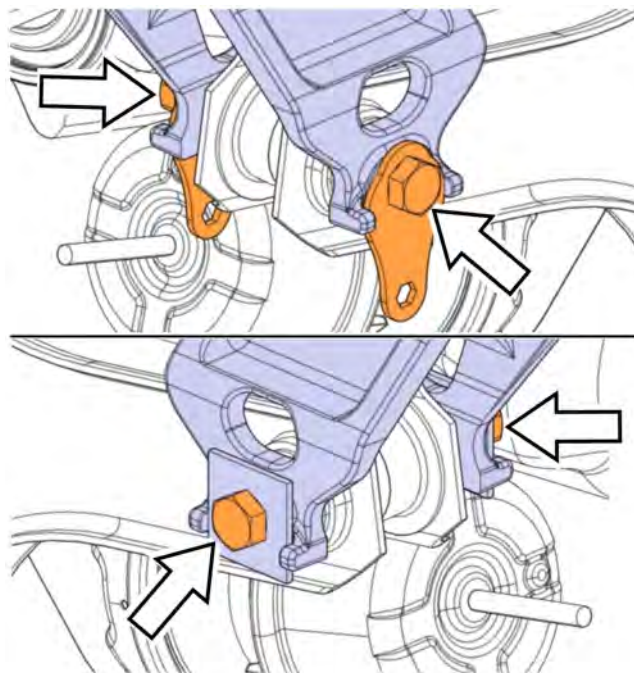

W7104645



24 Remove the wheel chocks.

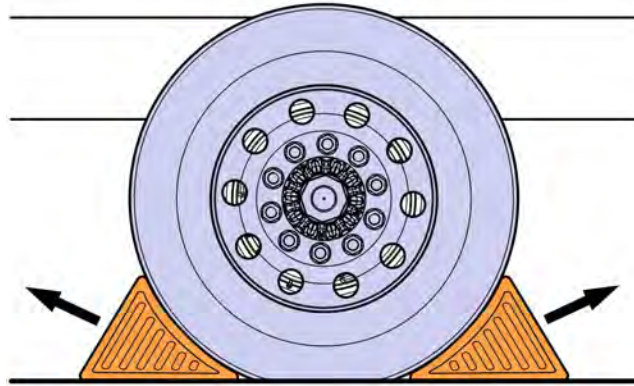

W7086759

25 Perform an alignment on the drive axles.

**Reimbursement**

<b>This repair may be eligible for reimbursement if a product failure was experienced within time and mileage limits of the applicable Warranty coverage. Reimbursement is obtained via the normal claim handling process.</b>	<b>UCHP Reimbursement</b>	<b>eWarranty Reimbursement</b>
<b>Claim Type (used only when uploading from the Dealer Bus. Sys.)</b>	01	01
<b>Labor Code</b>		
Primary Labor Code (Twin-Y Suspension, Trailing Blade, Replacement) Mack Axles	7229-03-09-02 9.1 hrs	1353F-01-80 9.1 hrs
<b>Causal Part</b>	21649231	21649231

MACK Trucks North America reserves the right to make any changes in design or to make additions to or upon its products without incurring any obligations to install the same on vehicles previously built.