

August 30, 2016

03595 Version 4

Audio Unit Volume Fluctuates

 Supersedes 16-025, dated August 20, 2016, to revise the information highlighted in **yellow**.

AFFECTED VEHICLES

Year	Model	Trim	VIN Range
2016	Pilot	2WD EX, EX-L, Touring	5FNYP5H...GB000000 thru 5FNYP5H...GB041175
2016	Pilot	AWD EX, EX-L, Touring	5FNYP6H...GB000000 thru 5FNYP6H...GB085554

REVISION SUMMARY

Under REPAIR PROCEDURE, a picture was updated.

SYMPTOM

The audio unit volume fluctuates when listening to FM.

POSSIBLE CAUSES

The remote tuner unit has a software problem.

CORRECTIVE ACTION

Replace the tuner unit.

PARTS INFORMATION

Part Name	Part Number	Quantity
Tuner Unit	39800-TG7-A02	1

WARRANTY CLAIM INFORMATION

The normal warranty applies.

Operation Number	Description	Flat Rate Time	Defect Code	Symptom Code	Template ID	Failed Part Number
0101G6	Replace the remote tuner unit.	0.8 hr	03214	03217	16-025A	39800-TG7-A01

Skill Level: Repair Technician

CUSTOMER INFORMATION: The information in this bulletin is intended for use only by skilled technicians who have the proper tools, equipment, and training to correctly and safely maintain your vehicle. These procedures should not be attempted by "do-it-yourselfers," and you should not assume this bulletin applies to your vehicle, or that your vehicle has the condition described. To determine whether this information applies, contact an authorized Honda automobile dealer.

REPAIR PROCEDURE

NOTE: When replacing the remote tuner unit, write down the audio unit radio presets (if possible), and enter them into the new tuner unit.

1. Open the caps, then remove the bolt and screw.

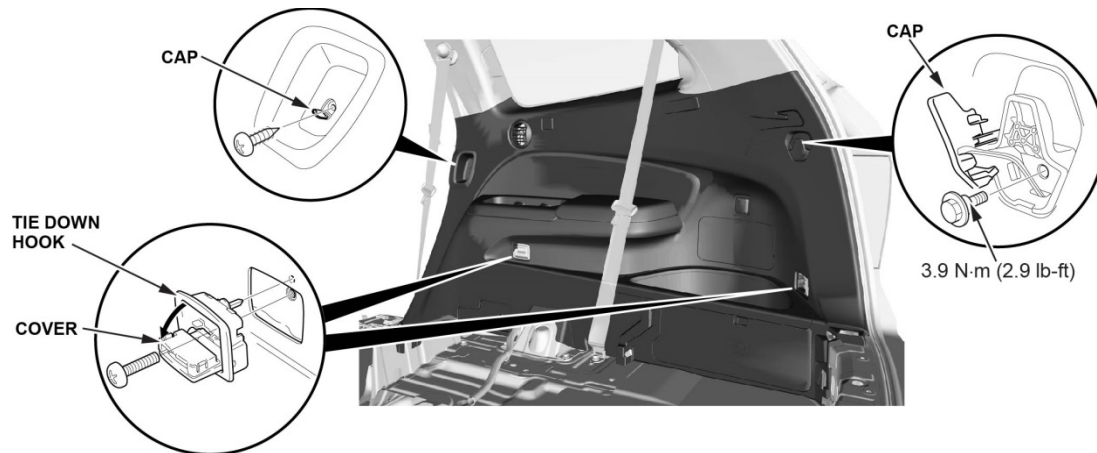

2. Pry out the covers and remove the screws. Then remove the tie down hooks.
3. Pull out the rear door opening seal and tailgate weatherstrip as needed.

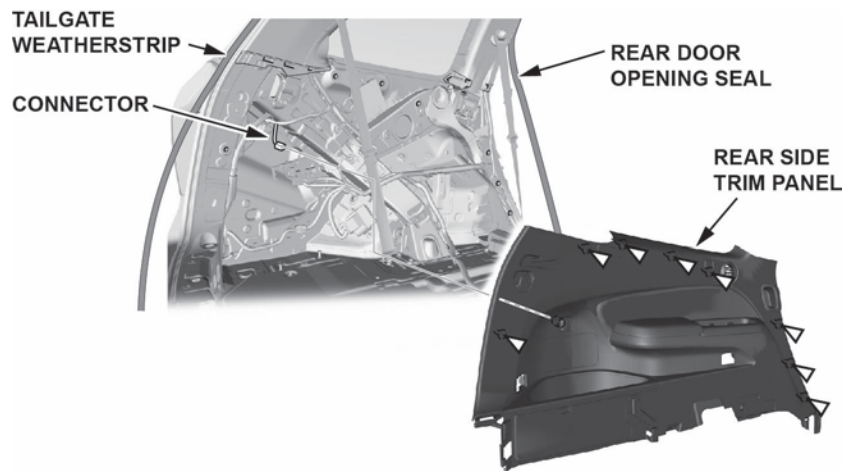

4. Remove the rear side trim panel.

5. Disconnect the connectors, then remove the harness clip.

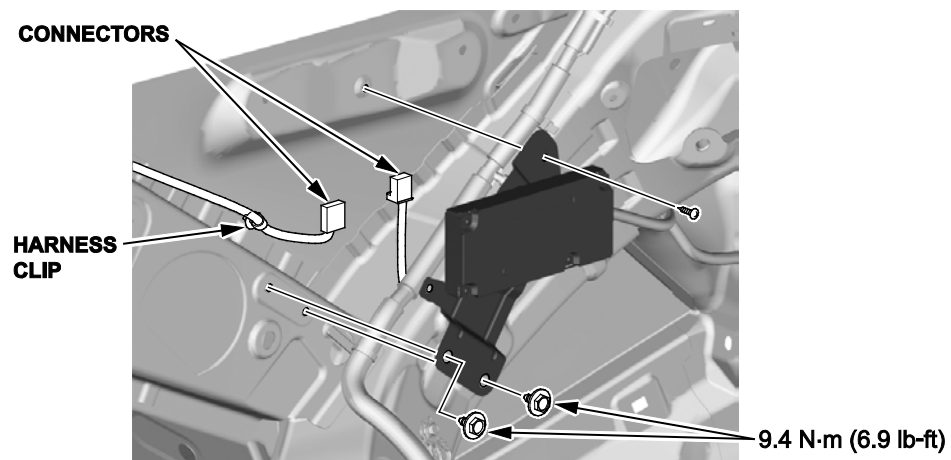

6. Remove the tuner unit.
7. Install the new tuner unit and torque the bolts to **9.4 N-m (6.9 lb-ft)**.
8. Reconnect the connectors and harness clip.
9. Install the trim panel.

END