



**\*\* CONFIDENTIAL \*\***  
Technical Service Bulletin 2016-0929

**DATE:** December 16, 2016  
**TO:** E-ONE Dealers and Customers  
**FROM:** Kevin Kearns, Customer Support Manager  
**SUBJECT:** **Brigade 360 Camera System Not Recording with MDR's**

E-ONE vehicles can be ordered equipped with several camera systems. Camera Systems options are dependent on our customer requirements, including front facing camera, left or right side facing cameras, rear facing cameras and Bird's Eye view cameras. Camera images can be viewed and/or recorded for later evaluation.

The Brigade 360 camera system offers a 360 degree bird's eye view of the vehicle. The system consists of 4 cameras located on front, left, right and rear of the vehicle. The system can also be equipped with an MDR recording device. The images are stored internally in the device and can be retrieved for evaluation. While all camera views are being recorded individually while driving, individual camera views are selected based on events. The 360 degree bird's eye view is only recorded while the vehicle is stationary with the Park Brake applied. The Brigade 360 MDR can also be configured to record all four cameras at all times, ignoring all triggers. Since this recording option has been recognized to be of value when investigating incidents, E-One has decided to facilitate this option to our customers in the field with Brigade 360 camera systems and MDR's installed.

E-ONE is currently in the process of scheduling service technicians and coordinating with our customers the access to the vehicle to have an update performed to activate passive recording with all four cameras. The update process should take several hours and shall consist of adding four additional video cables to the MDR, followed by a system recording check. The technician will be able to provide instructions on how to view and retrieve the recorded content.

This is considered a product improvement, and will be a running change on newly built E-ONE apparatus.

If you have questions concerning this bulletin, please contact the E-ONE Customer Support Department at (352) 861-3612.

Kevin Kearns  
Customer Support Manager

# Brigade 360 Camera System MDR Update Instructions

## Summary:

This document will serve as instructions on adding the required video cables.

## Parts Required:

Video Cable Splitter (E-One P/N 1065015), 4 Each

Video Cable Extension Brigade, 3 meter (E-One P/N 1065559-008), 4 Each

Video Cable Extension Brigade, 10 meter (E-One P/N 1065559-009), 4 Each

**IMPORTANT:** Before starting any work on the MDR, turn off main power to truck.

## Instructions:

1. Locate the MDR on the vehicle, typically rear of driver seat or center dash.



2. Locate the Brigade 360 ECU unit, typically officer under dash

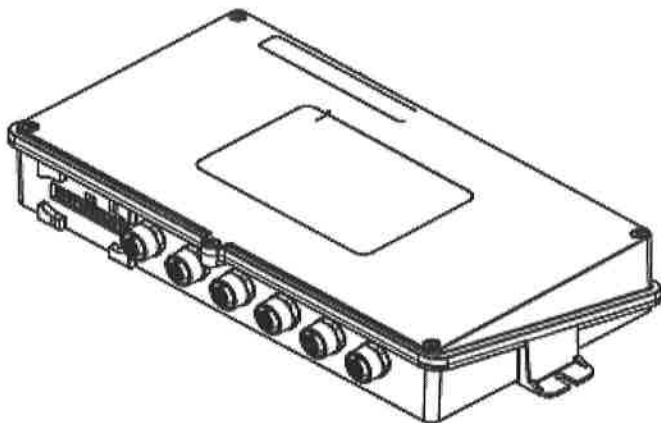

3. Disconnect the four cameras video cables connected to the ECU
4. Using the provided video cable splitter, (P/N 1065015) to split the camera supplied video signal to both the ECU and the MDR. Do this for all four cameras video cables
5. Use the provided video cable extensions (E-One P/N xxxxxxx) to run the four video signal to the MDR.
6. Use the Brigade MDR Viewer Software Download (see attached installation instructions) to download the viewer software to a PC or Laptop.
7. Validate that system is recording correctly.