

Engine Rattles at Cold Start-Up

AFFECTED VEHICLES

Year	Model	Trim	VIN Range
2013	CR-V	2WD	5J6RM3H...L033151 thru END
2013	CR-V	2WD	2HKRM3H...H513165 thru END
2013	CR-V	2WD	3CZRM3H...G705692 thru END
2013	CR-V	4WD	5J6RM4H...L067673 thru END
2013	CR-V	4WD	2HKRM4H...H659280 thru END
2014	CR-V	2WD/4WD	ALL
2013	Crosstour	2WD	5J6TF3H...L004310 thru END
2014-15	Crosstour	2WD	ALL

SYMPTOM

At cold start-up, the engine rattles loudly for about 2 seconds. This may be intermittent and occurs when the outside temperature is below 40° F.

POSSIBLE CAUSES

The variable valve timing control (VTC) actuator is defective.

CORRECTIVE ACTION

Replace the VTC actuator. This procedure does not require the complete removal of the cam chain and associated parts, so repair time is much shorter.

TOOL INFORMATION

Tool Name	Tool Number	Quantity
Stopper (lock pin)	14511-PNA-003	1
Tappet Adjuster	07MAA-PR70110	1
Tappet Lockout Wrench	07MAA-PR70120	1

REQUIRED MATERIALS

Part Name	Part Number	Quantity
Honda Bond HT (One tube repairs 10 vehicles.)	08718-0004	1

CUSTOMER INFORMATION: The information in this bulletin is intended for use only by skilled technicians who have the proper tools, equipment, and training to correctly and safely maintain your vehicle. These procedures should not be attempted by "do-it-yourselfers," and you should not assume this bulletin applies to your vehicle, or that your vehicle has the condition described. To determine whether this information applies, contact an authorized Honda automobile dealer.

PARTS INFORMATION

Part Name	Part Number	Quantity
VTC Actuator	14310-R5A-305	1

WARRANTY CLAIM INFORMATION

The normal warranty applies.

Operation Number	Description	Flat Rate Time	Defect Code	Symptom Code	Template ID	Failed Part Number
1101Z9	Replace the VTC actuator.	2.0 hrs	03214	04216	16-012A	14310-R44-A01

Skill Level: Repair Technician

DIAGNOSIS

If viewing this service bulletin on SIS and your computer has sound, click on the picture below to hear a sample of the engine's rattle.

1. Allow the engine oil to drain from the VTC system by not starting the engine for at least 6 hours.
2. Start the engine and immediately listen for a loud rattle.



On start-up, do you hear a loud engine rattle that lasts about 2 seconds?

Yes – Go to REPAIR PROCEDURE

NO –

- If you hear a different noise, continue with normal troubleshooting.
- If you do not hear an abnormal noise, get more information from the customer and, if needed, continue with normal troubleshooting.

REPAIR PROCEDURE

This procedure is in an outline form that you can also use as a checklist for the repair. If you need more details, refer to the service information for the following procedures:

- Cylinder Head Cover Removal
 - Cylinder Head Cover Installation
 - Valve Clearance Adjustment
1. Remove the frame (strut) brace (if equipped).
 2. Remove the engine cover.

3. Remove the ignition coil cover and the ignition coils.

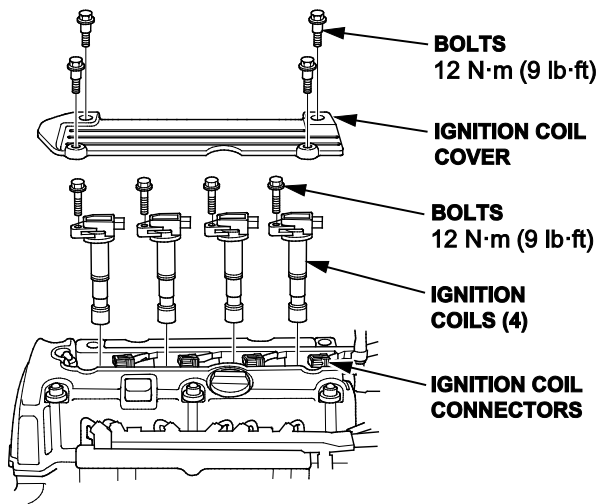

4. Remove the engine oil dipstick, then disconnect the breather hose and the brake booster vacuum hose from the cylinder head cover.

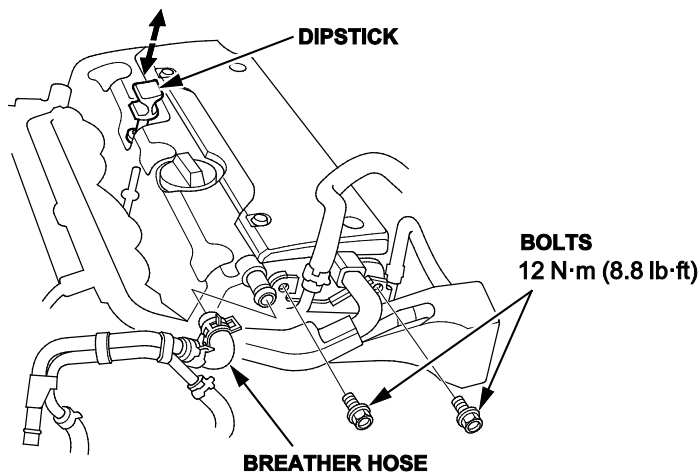

5. Remove the two bolts holding the EVAP canister purge valve bracket to the cylinder head.
6. Remove the cylinder head cover.
7. Raise the vehicle on a lift.
8. Turn the front wheels or remove the right front wheel.
9. Remove the splash shield to provide access to the crankshaft pulley.
10. Remove the camshaft auto-tensioner (chain case) cover.
11. Rotate the crankshaft clockwise to top dead center (TDC) No. 1 cylinder.

12. Rotate the crankshaft counterclockwise to compress the auto-tensioner. Align the hole in the lock and auto-tensioner, then insert a 1.2 mm (0.05 in)-diameter stopper (lock pin).

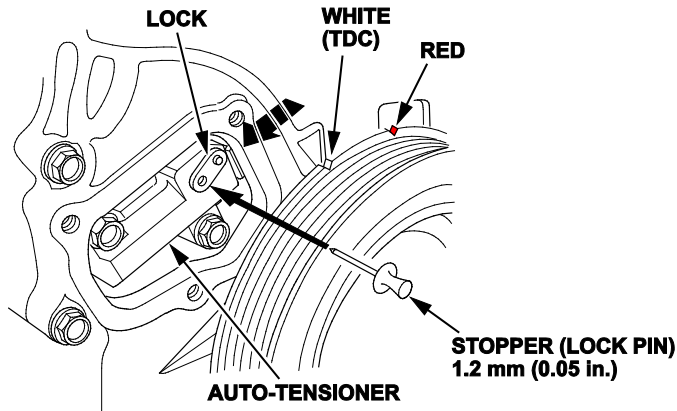

13. Rotate the crankshaft clockwise to TDC No. 1 cylinder.
14. Lower the vehicle.
15. Mark the timing chain at the punch marks on the exhaust camshaft sprocket and VTC actuator. Secure the chain to the sprocket with a wire tie.

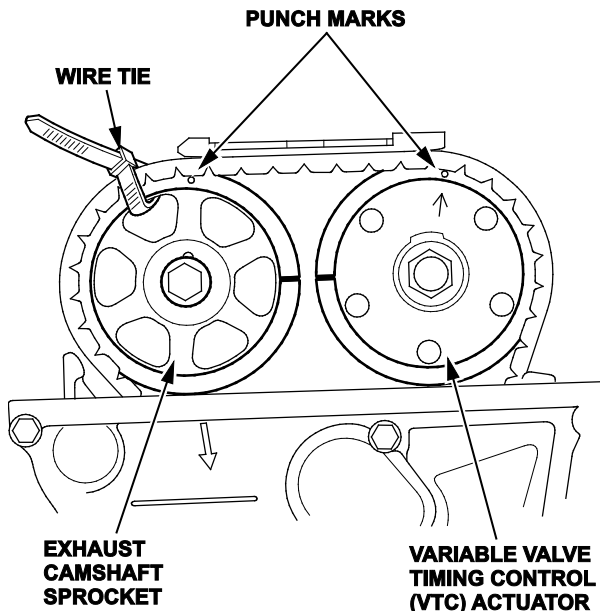

16. Loosen the camshaft holder bolts, in sequence, two turns at a time.
17. Remove the five camshaft holders. Set them aside on a clean surface in the exact order and position that they were removed from the cylinder head.
18. Carefully tip up the end of the intake camshaft until there is enough slack for an assistant to lift the chain off the VTC actuator teeth.
19. Remove the intake camshaft/VTC actuator assembly while the assistant keeps light tension on the chain. Place the camshaft/VTC actuator assembly on a clean, padded workbench.
20. Secure the timing chain to the A/C compressor hose using a wire or zip tie to keep it from falling into the front cover.

21. On the workbench, as an assistant holds the camshaft steady with an open-end wrench, remove the VTC actuator mounting bolt, then separate the VTC actuator from the camshaft. Discard the VTC actuator.

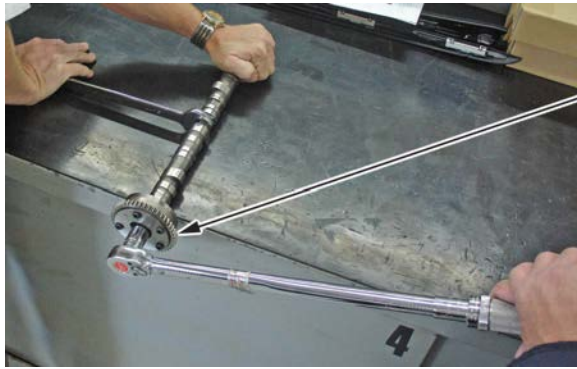

VTC ACTUATOR
Do not reuse.

22. Before installing the new VTC actuator, make sure it is in the unlocked position.

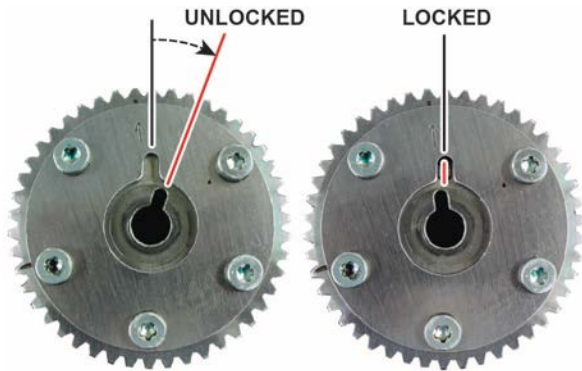

23. Install the new, unlocked VTC actuator onto the camshaft; do not force it on.
24. Once fitted, with the VTC actuator facing you, carefully rotate it counterclockwise until it engages the camshaft's locator pin. When installed and rotated this way, the VTC actuator will not lock. Apply clean engine oil to the mounting bolt threads, then install the mounting bolt, finger tight.

NOTE:

- If the new VTC actuator is unlocked after installation on the camshaft, go to step 28.
 - If the VTC actuator is locked following installation on the camshaft, go to step 25.
25. To unlock a locked VTC actuator, apply clean engine oil to the mounting bolt thread, then install the mounting bolt on the actuator, finger tight.

26. Cover pressure port #1 on the camshaft with several wraps of electrical tape. Secure the tape with a zip tie as shown.

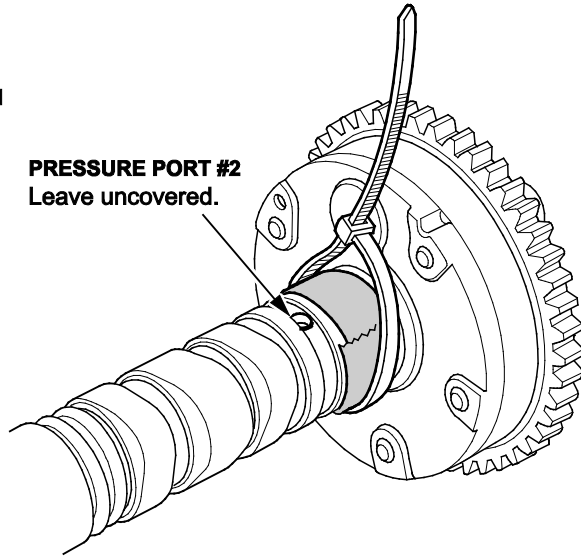
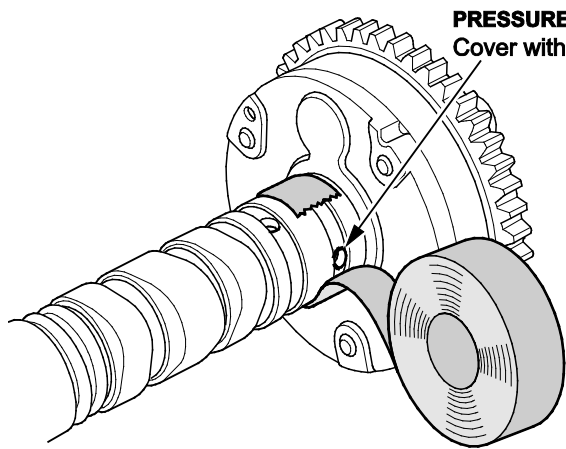

27. Apply compressed air to pressure port #2. While compressed air is being applied to pressure port #2, rotate the VTC actuator by hand to the unlock position.

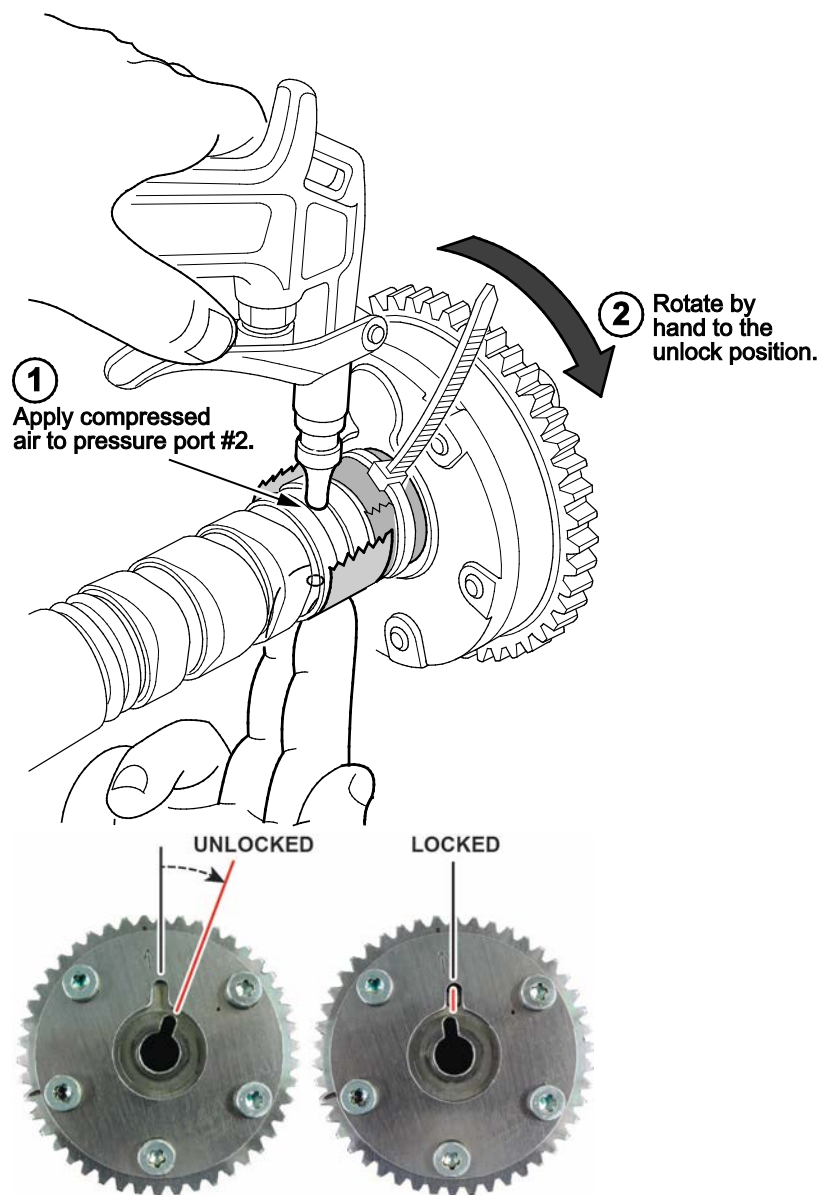

28. Have an assistant hold the camshaft/VTC actuator assembly steady on the padded workbench with an open-end wrench. Use a torque wrench to torque the mounting bolt to **113 N·m (83 lb-ft)**.

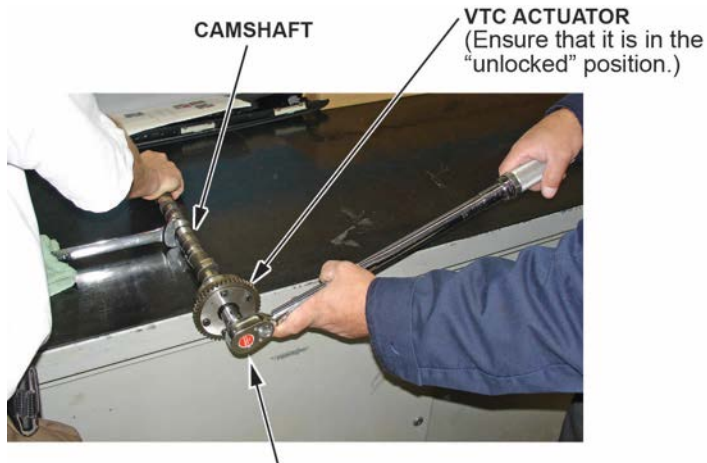

Torque to 113 N·m (83 lb-ft).

NOTE: Be careful not to scratch or damage the camshaft. Also, do not use an impact wrench to tighten the mounting bolt; it will cause internal damage to the VTC actuator housing, vanes, or lockpin.

29. After the mounting bolt is torqued, rotate the VTC actuator to the locked position.
30. Remove the wire ties as an assistant keeps light tension on the chain.
31. Slide the camshaft/VTC actuator in at an angle so that the chain can slip over the actuator's teeth.
32. Line up the marks you made on the chain with the punch marks on the exhaust camshaft sprocket and VTC actuator.

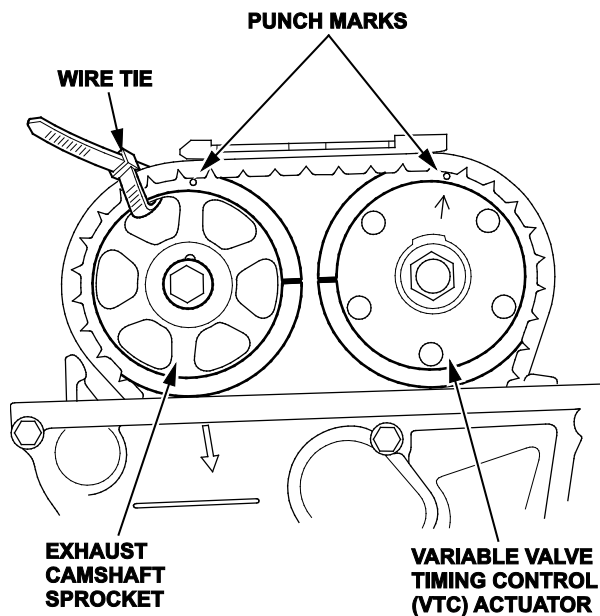

33. Apply engine oil to the journals and caps for both camshafts. Lower the camshaft/VTC actuator assembly onto its journals.
34. Install the camshaft holders. Tighten them two turns at a time, starting in the middle and working your way outward, following the numbered sequence.

CR-V

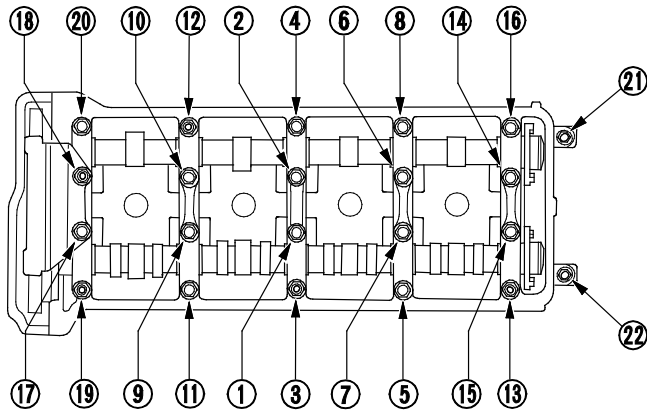

Specified Torque
 8 x 1.25 mm - 22 N·m (16 lb·ft)
 6 x 1.0 mm - 12 N·m (9 lb·ft)
 6 x 1.0 mm Bolts: ⑳, ㉑

CROSSTOUR

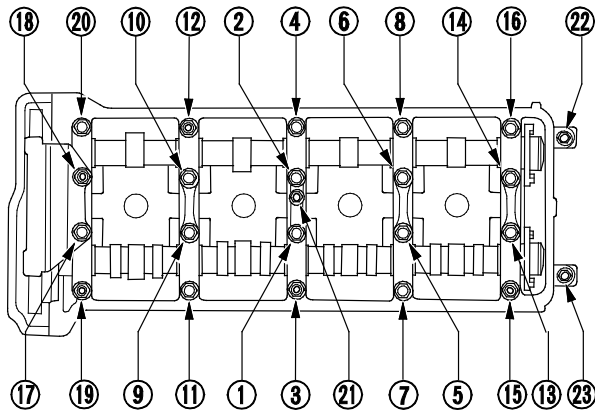

Specified Torque
 8 x 1.25 mm - 22 N·m (16 lb·ft)
 6 x 1.0 mm - 12 N·m (9 lb·ft)
 6 x 1.0 mm Bolts: ㉑, ㉒, ㉓

35. Remove the lock pin from the auto-tensioner.
36. Rotate the crankshaft in the direction of engine rotation (clockwise) two full turns, then stop at the TDC mark. Make sure both camshafts line up, as shown in step 15.

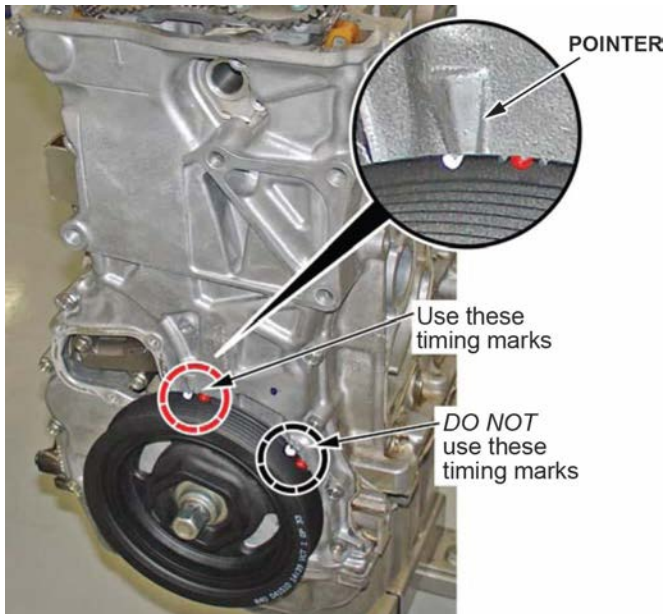

37. Inside the cylinder block, visually confirm that the timing chain is properly riding on its guide, and has not slipped behind the guide in the block. If so, realign the chain as needed.

38. Remove the old sealant, dry, reseal, then reinstall the auto-tensioner (chain case) cover.

NOTE: Wait 30 minutes before adding oil, (if needed), then wait 3 hours before starting the engine.

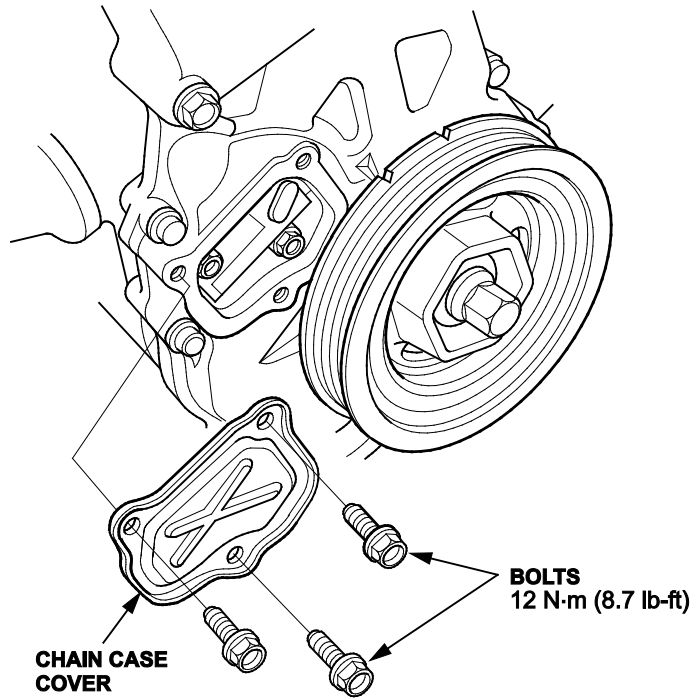

39. Check the valve clearance using a tappet adjuster. Adjust if needed.

Intake: 0.21 – 0.25 mm (0.008 – 0.010 in)

Exhaust: 0.25 – 0.29 mm (0.010 – 0.011 in)

40. Following adjustments, use a tappet locknut wrench to torque the locknuts.

Intake and Exhaust: 14 N·m (10 lb-ft)

41. Raise the vehicle.

42. Reinstall the splash shield.

43. Straighten the wheels or reinstall the right front wheel (if removed).

44. Lower the vehicle.

45. Check the sparkplug seals for damage. If any seals are damaged, replace them.

NOTE: Check the head cover gasket. Replace if needed.

46. Install the head cover gasket in the groove.

47. Remove the entire liquid gasket from the chain case and the No. 5 rocker shaft holder.

48. Clean the head cover contacting surfaces with a clean shop towel.

49. Reinstall the cylinder head cover, tightening the bolts in three steps. In the final step, torque all bolts in sequence to **12 N·m (8.7 lb-ft)**.

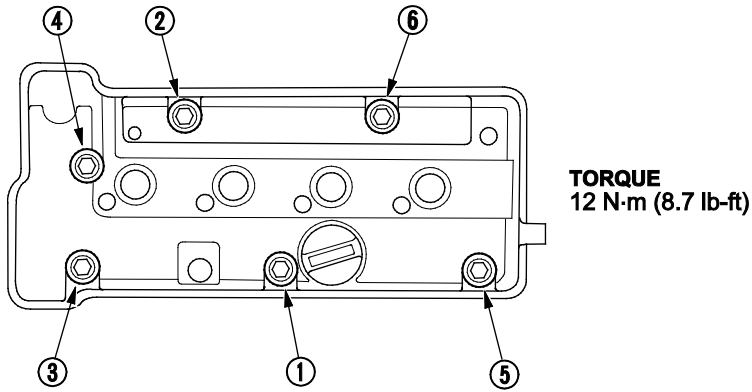

50. Reinstall the EVAP canister purge valve bracket.

51. Reinstall the engine oil dipstick and reconnect the breather hose and the brake booster vacuum hose.

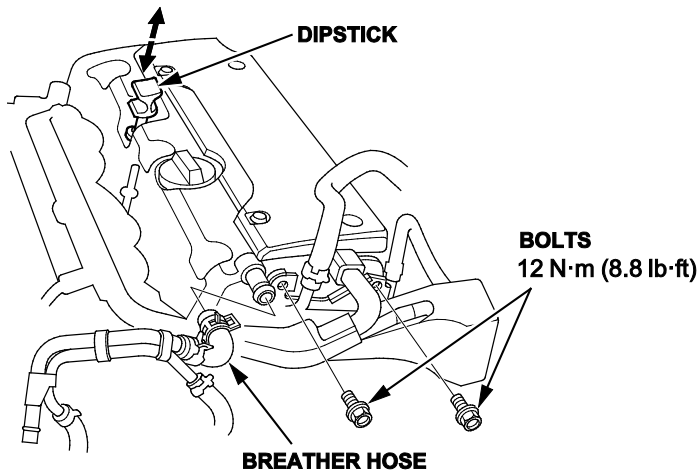

52. Reinstall the ignition coils and the ignition coil cover.

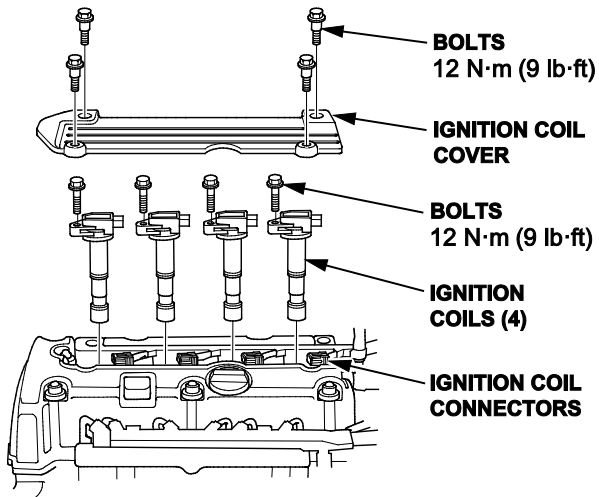

53. Reinstall the engine cover.

54. Reinstall the frame (strut) brace (if equipped). Torque the bolts to **22 N·m (16 lb-ft)**.

END