

February 5, 2016

03001 Version 1

**Starter Grinds or Spins at Startup****AFFECTED VEHICLES**

Year	Model	Trim	VIN Range
2013–15	Accord	V6 with A/T only	ALL
2013–15	Crosstour	V6 with A/T only	ALL

**SYMPTOM**

The starter grinds or spins at startup.

**POSSIBLE CAUSES**

The clearance between the starter motor gear and the torque converter ring gear is not optimal.

**CORRECTIVE ACTION**

Replace the starter and rotate the torque converter clockwise one bolt-hole.

**PARTS INFORMATION**

Part Name	Part Number	Quantity
Starter (includes gasket)	31200-5G0-A02	1

**WARRANTY CLAIM INFORMATION**

The normal warranty applies.

Operation Number	Description	Flat Rate Time	Defect Code	Symptom Code	Template ID	Failed Part Number
2181BD	Replace the starter and rotate the torque converter one bolt hole.	0.9 hr	07406	04201	16-002A	31200-5G0-A02

Skill Level: Repair Technician

**CUSTOMER INFORMATION:** The information in this bulletin is intended for use only by skilled technicians who have the proper tools, equipment, and training to correctly and safely maintain your vehicle. These procedures should not be attempted by "do-it-yourselfers," and you should not assume this bulletin applies to your vehicle, or that your vehicle has the condition described. To determine whether this information applies, contact an authorized Honda automobile dealer.

## REPAIR PROCEDURE

1. Make sure the ignition switch is turned to OFF.
2. Disconnect and isolate the negative cable with the battery sensor from the battery.

### NOTE:

- Always disconnect the negative side first.
  - To protect the battery sensor connector from damage, do not hold it when removing the negative terminal.
  - Do not disconnect the battery sensor from the negative terminal.
3. Disconnect the positive cable and the battery terminal from the battery.
  4. Remove the battery setting plate and the battery.
  5. Remove the air cleaner.
  6. Loosen the bolts as shown.

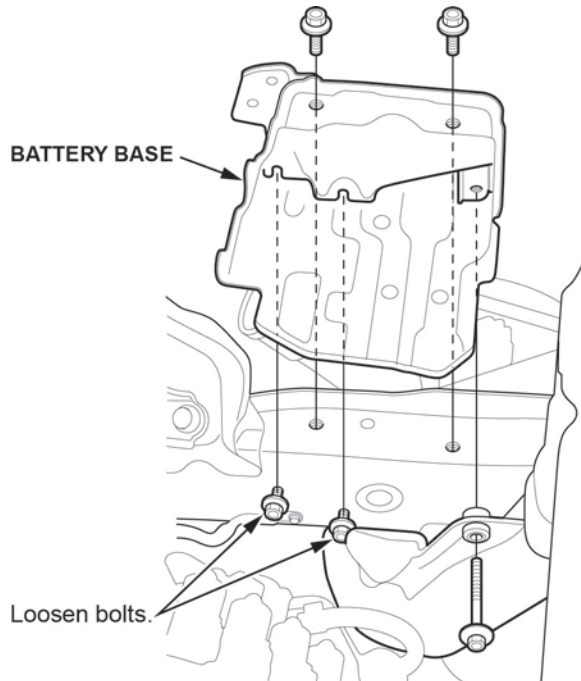

7. Remove the battery base.
8. Remove the splash separator.

*Accord*

**SPLASH SEPARATOR**

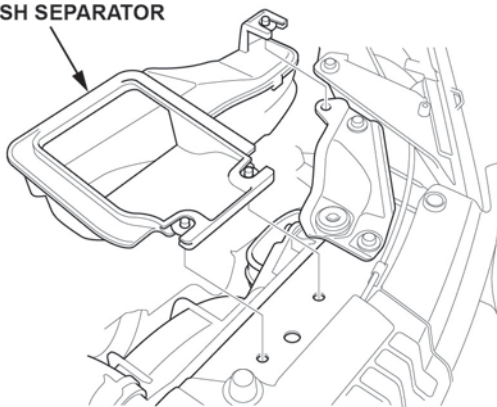

*Crosstour*

**SPLASH SEPARATOR**

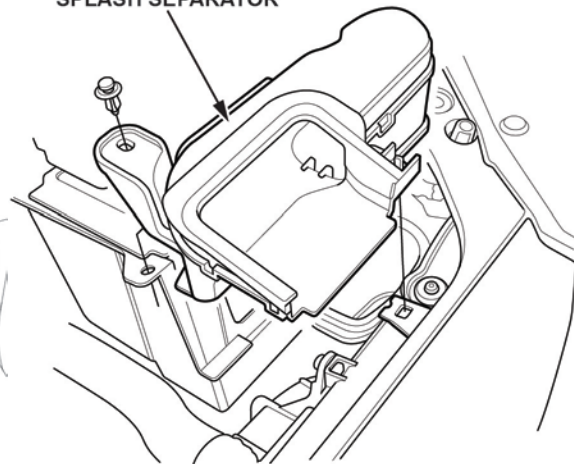

9. Remove the lower radiator hose from the lower radiator hose bracket.

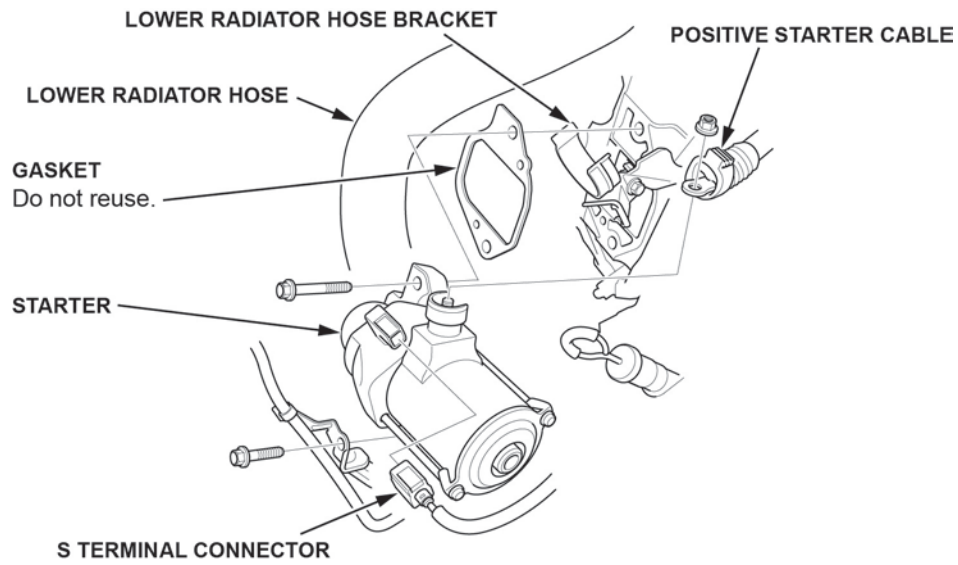

10. Disconnect the positive starter cable and the S terminal connector.
11. Remove the starter.
12. Remove the torque converter cover.

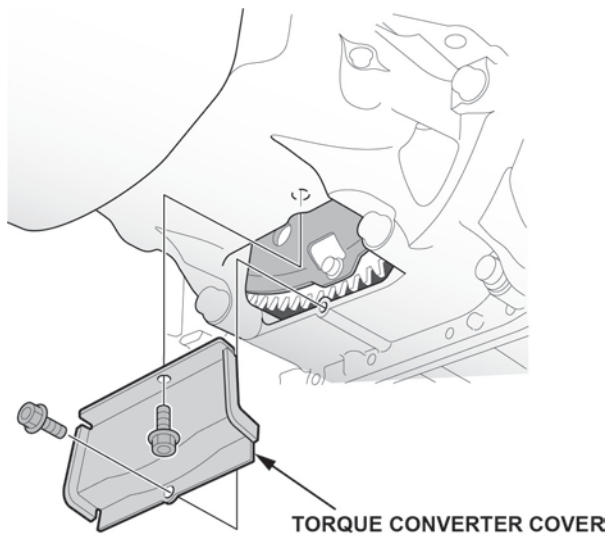

13. Rotate the crankshaft and remove all eight bolts.

NOTE: Do not remove the final bolt until ready to rotate the torque converter.

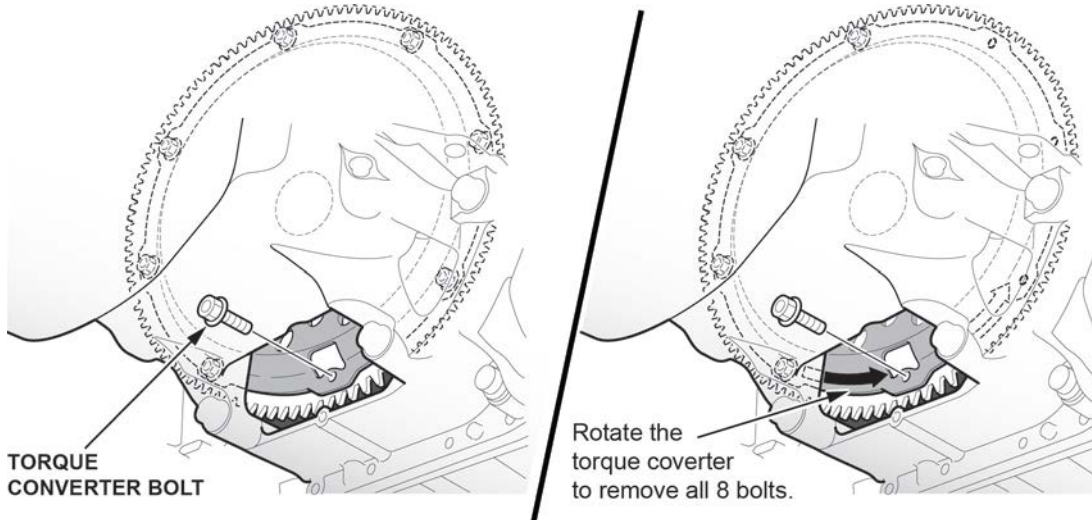

14. Rotate the torque converter clockwise one bolt hole. Then, install the bolts and torque them to **12 N·m (9 lb-ft)**.

NOTE: Moving the torque converter more than one bolt hole will index the flexplate and torque converter incorrectly. The torque converter must be rotated as shown.

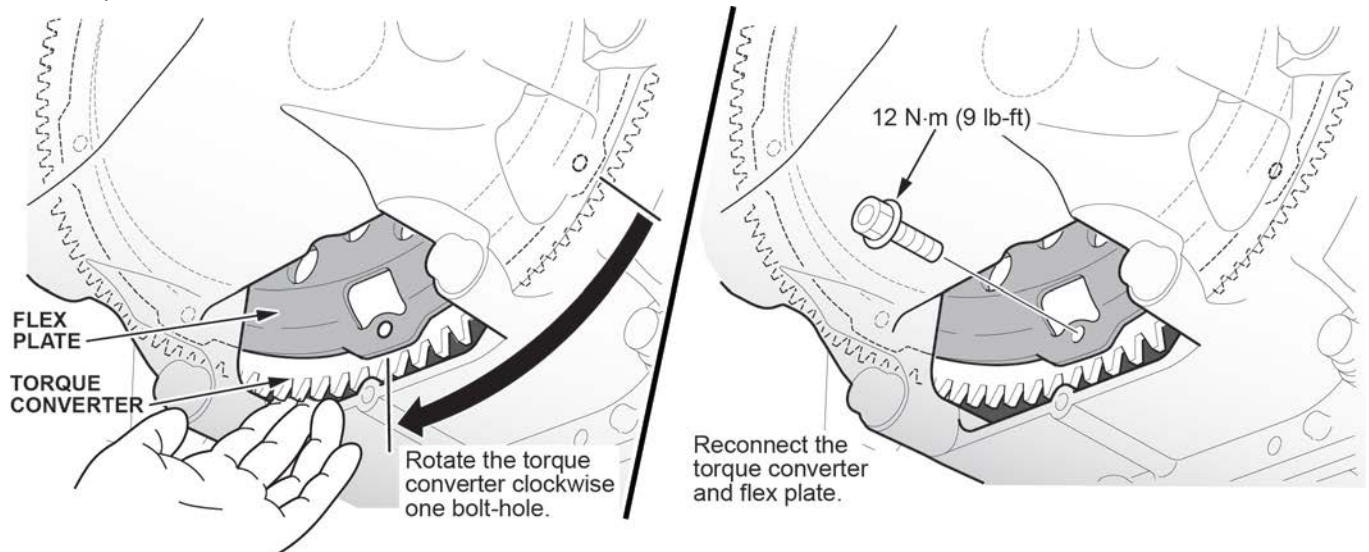

15. Mark the torque converter and the flex plate as shown. Then, write the bulletin number (16-002) on the flex plate with a permanent marker or paint marker.

NOTE: If there is a previous alignment mark and a reference to this bulletin, no further rotation can be done. A new torque converter will have to be installed.

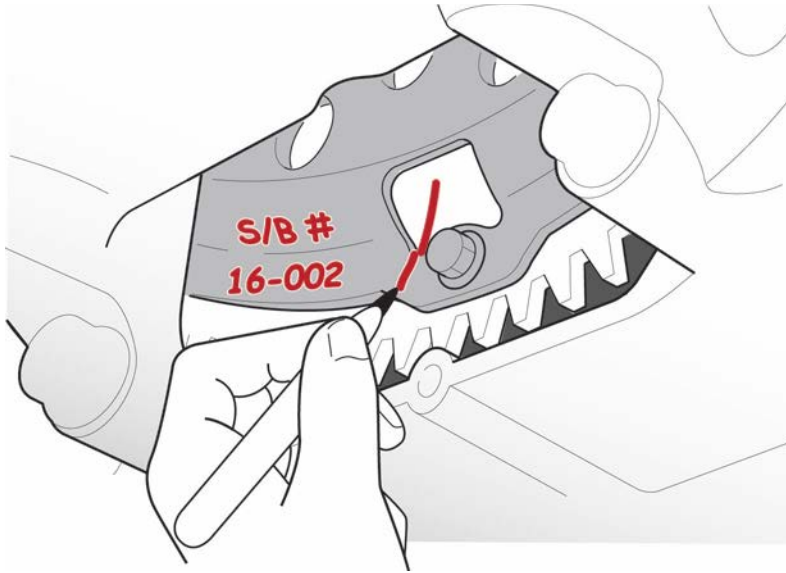

16. Install the torque converter cover and torque the bolts to **12 N·m (9 lb-ft)**.

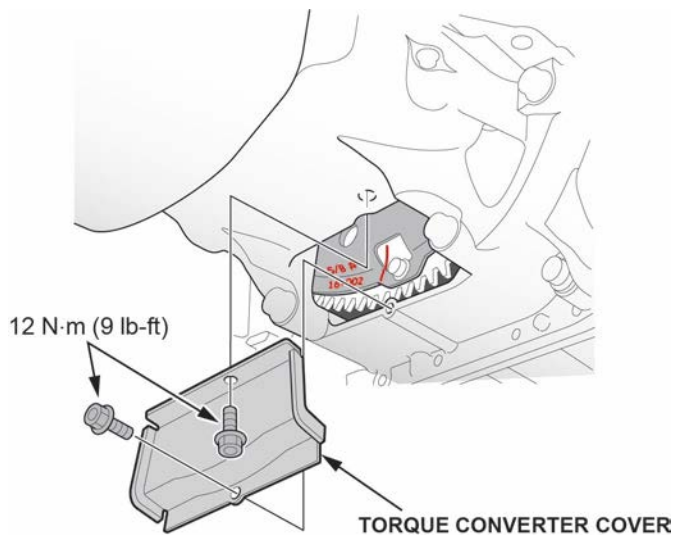

17. Install the new starter and gasket. Then, torque the bolts to **45 N·m (33 lb-ft)**.
18. Install the splash separator.
19. Do the battery installation procedure.
20. Install the battery base and torque the bolts to **22 N·m (16 lb-ft)** and **10 N·m (7 lb-ft)**.
21. Start the engine to make sure it works properly.

END