



Reliability Driven™

# Service Bulletin No. 441

<b>MODEL</b> J4500	<b>TYPE</b> Field Change Program	<b>SECTION/GROUP</b> 12-Suspension	<b>DATE</b> Dec. 22, 2016
<b>SUBJECT</b> LEVEL SENSOR GUARD			
<b>CONDITIONS</b>			

### Customer Complaint:

Motor Coach Industries ("MCI") has become aware that the potential may exist for the level sensor assembly to contact the level sensor guard while the optional rear rise suspension feature is activated, resulting in damage to the level sensor.

### Cause:

Design and manufacturing tolerances result in interference.

### Corrective Action:

As a result, MCI strongly urges owners of the MY2017J4500 coaches listed in this bulletin to implement the steps in this procedure as soon as possible.

2MG3JM8AXHW067874	2MG3JM8A1HW067889	2MG3JM8A8HW067890	2MG3JM8AXHW067891
2MG3JM8A1HW067892	2MG3JM8A3HW067893	2MG3JM8A5HW067894	2MG3JM8A7HW067900
2MG3JM8A2HW067903	2MG3JM8A4HW067904	2MG3JMBA9HW067907	2MG3JM8A2HW067870
2MG3JMBA5HW067872	2MG3JM8A7HW067895	2MG3JM8A0HW067897	2MG3JM8A2HW067898
2MG3JM8A4HW067899	2MG3JM8A9HW067901	2MG3JM8A0HW067902	2MG3JMBA7HW067906
2MG3JMBA0HW067908	2MG3JMBA2HW067909	2MG3JMBA9HW067910	2MG3JMBA0HW067911
2MG3JMBA2HW067912	2MG3JMBA6HW067914	2MG3JMBA7HW067923	

### Parts

Qty.	New P/N	Description
1	12-03-1598	Guard, Level Sensor, Roadside
1	12-03-1599	Guard, Level Sensor, Curbside

Service Procedure:



**Read this entire procedure before beginning work.**

**Use Safe Shop Practices At All Times.**

1. Turn the main battery disconnect to the OFF position.
2. Check both sides of the tires.

## **WARNING**

**DO NOT** place safety stands in any other location than shown in this procedure and Section 3F in the MCI J4500 Maintenance Manual.

3. Position safety stands underneath the coach in only the specified locations shown in Section 3F in the MCI J4500 Maintenance Manual ( as shown in Figure 1 ).

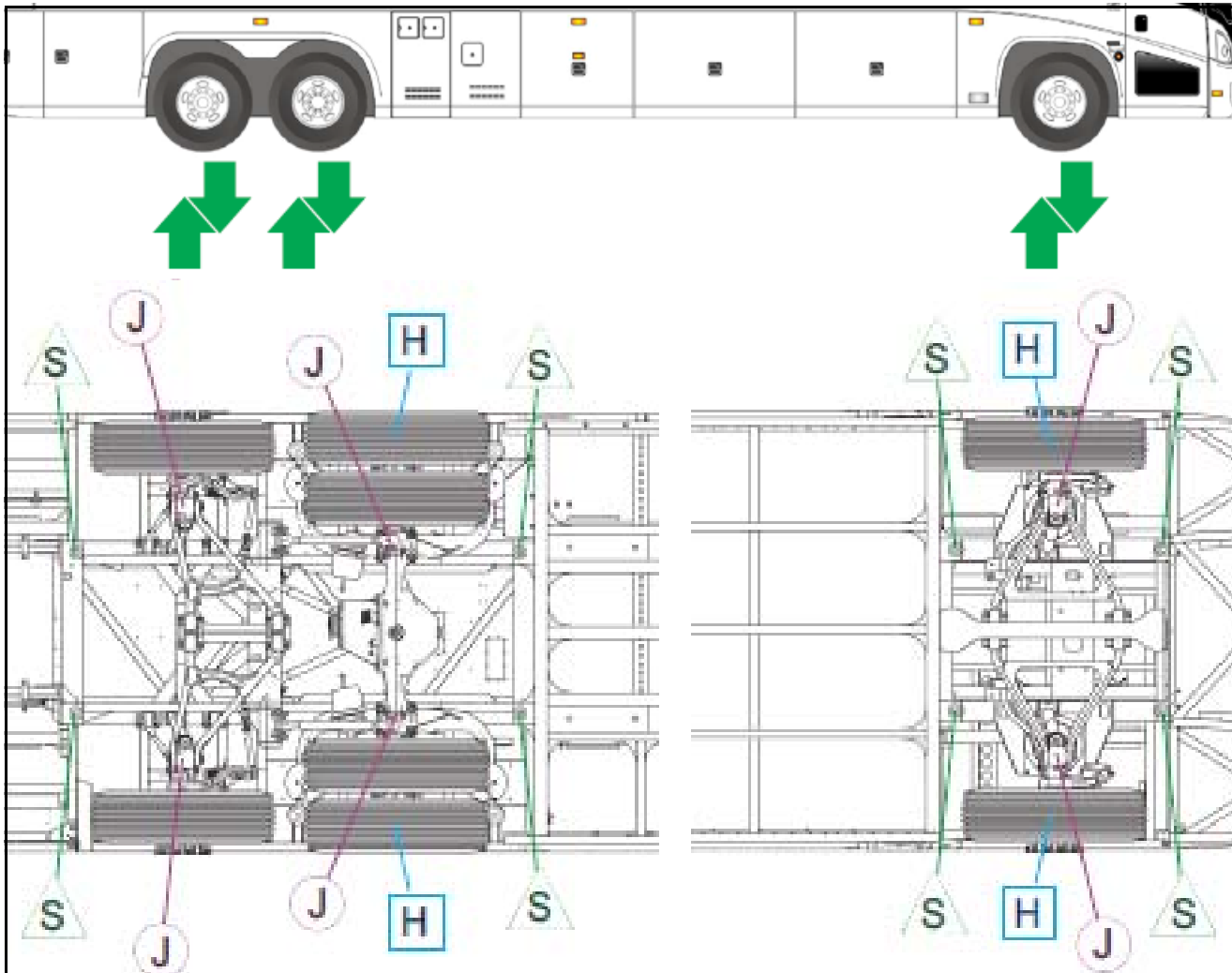

**Figure 1. J4500 coach safety stands location.**

Item	Figure 1 Description
S	Safety Stand ( Primary locations )

4. Standing rearward of the tag wheel, locate the level sensor guard shown in Figure 2.



**Figure 2. Location of the level sensor guard.**

5. Locate the mounting hardware securing the level sensor guard to the coach structure ( refer to Figure 3 ). Remove and retain the four ( 4 ) capscrews, washers and lock washers, to be re-installed at a later step in this procedure. Remove and discard the existing level sensor guard.



**Figure 3. Mounting hardware.**

6. Orient the new level sensor guard, p/n 12-03-1598 or 12-03-1599, to the existing mounting holes.
7. Using the existing hardware removed in Step 5, secure the level sensor guard to the structure. Torque to 8-10 ft-lbs. Apply torque seal over the face of the torqued capscrews ( refer to Figure 4 for completed installation ).



**Figure 4. Completed installation of the level sensor guard**

8. Repeat Steps 5 to 7 on the opposite side of the coach.

*Procedure Complete.*



Mail or fax the completed limited warranty claim form and verification form to MCI's warranty department, or photocopy and mail to:

MCI Fleet Support  
Attn: Warranty Department  
7001 Universal Coach Drive  
Louisville, KY 40258  
Fax Number 1-800-360-8886

to receive credit for the hours used to complete this task. Contact the MCI Fleet Support Technical Center at 1-800-241-2947 for any further information.

***Field Change Program Conditions:***

The parts required for this rework will be supplied without charge.

A labor allowance of 0.9 hours will be granted for this rework on affected J4500 coaches.

This labor allowance will be credited to your MCI Fleet Support Parts Account on receipt of the attached "MCI Field Change Program Verification Form" and a "Warranty Claim Form" as detailed in your Owner Warranty manual to MCI's Warranty department. A "MCI Field Change Program Verification Form" needs to be submitted for each VIN affected. Photocopy the attached "MCI Field Change Program Verification Form" as required for the number of affected coaches in your fleet.

This program will end on July 14, 2017.

Motor Coach apologizes for any inconvenience resulting from this campaign, but urges you to implement this change as soon as possible.

Sincerely,

Motor Coach Industries



Reliability Driven™

## MCI FIELD CHANGE PROGRAM (FCP) VERIFICATION

<b>CONTACT INFORMATION</b>	
<b>CUSTOMER NAME:</b> _____	
<small>(PLEASE PRINT)</small>	
<b>FCP INFORMATION – ONE FORM PER UNIT</b>	
<b>FCP#:</b> _____	<b>Coach Model</b> _____ <b>Model Year</b> _____
<b>COACH SERIAL #:</b> <small>(At least the last 5 digits)</small>	<b>DATE COMPLETED</b> __ / __ / __
<b>MILEAGE:</b>	
<b><u>IMPORTANT:</u> TO RECEIVE CREDIT FOR ANY ALLOWABLE LABOR CHARGES, THIS VERIFICATION FORM MUST BE RETURNED TO MCI UPON COMPLETION OF THE FCP.</b>	
<b>SUBMITTED BY: (Please Print)</b> _____	
	<b>DATE</b> __ / __ / __
<b>TITLE: (Please Print)</b> _____	
<b>SIGNATURE:</b> _____	
<b>COMMENTS:</b>  	

**FAX TO: 800-360-8886**

**MAILING ADDRESS:**

**MOTOR COACH INDUSTRIES  
ATTN: WARRANTY DEPT.  
7001 UNIVERSAL COACH DRIVE  
LOUISVILLE, KY 40258**