



SERVICE CAMPAIGN BULLETIN

Reference:

NTB16-079

Date:

August 23, 2016

VOLUNTARY SERVICE CAMPAIGN 2016 TITAN XD; ELECTRONIC TAILGATE LOCK

CAMPAIGN ID #: PC466

APPLIED VEHICLES: 2016 Titan XD (A61)

Check Service COMM to confirm campaign eligibility.

INTRODUCTION

Nissan is conducting this voluntary service campaign on certain specific 2016 Titan XD vehicles to install an electronic tailgate lock that should have been installed on the vehicle from the factory, but was not. This service will be performed at no charge to the customer for parts or labor.

IDENTIFICATION NUMBER

Nissan has assigned identification number PC466 to this campaign. This number must appear on all communications and documentation of any nature dealing with this campaign.

DEALER RESPONSIBILITY

Dealers are to repair vehicles falling within range of this campaign that enter the service department. This includes vehicles purchased from private parties, vehicles presented by transient (tourists) owners, and vehicles in a dealer's inventory.

Nissan Bulletins are intended for use by qualified technicians, not 'do-it-yourselfers'. Qualified technicians are properly trained individuals who have the equipment, tools, safety instruction, and know-how to do a job properly and safely. NOTE: If you believe that a described condition may apply to a particular vehicle, DO NOT assume that it does. See your Nissan dealer to determine if this applies to your vehicle.

SERVICE PROCEDURE

Install the electronic tailgate lock using the installation instructions below.

PARTS INFORMATION

DESCRIPTION	PART NUMBER	QUANTITY
Electronic Tailgate Lock	999M2-W3005	1



GENUINE PARTS

INSTALLATION INSTRUCTIONS

DESCRIPTION: Electronic Tailgate Lock

APPLICATION: Nissan Titan

PART NUMBER: 999M2-W3005

Order parts using the Parts Information above. These part numbers are for installation instruction reference only.

KIT CONTENTS:

Item	Qty.	Part Description	Service Part Number
A	1	Electronic Tailgate Lock kit	999M2-W3005
B	1	Hardware Kit	999M2-W3004
C	1	Tailgate Harness	24025 EZ02A
D	1	Electronic Tailgate Lock main Harness	999M2-W3002
E	1	Harness Assembly With Relay	999M2-W3003
F	1	Installation Instruction Replacement Template	N/A

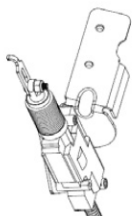

A



B

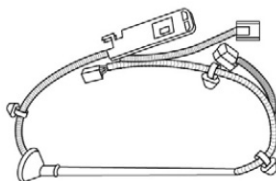

C



D



E

Expected: Read before installation!

Note: See also the following:

WARNING

To avoid electrical shock or personal injury, always wear the proper safety equipment when working on electrical systems. Use the correct tools and techniques for the job. Do not use excessive force. Do not use electrical components that are not approved for the vehicle. Do not use electrical components that are not approved for the vehicle.

USE ONLY THE CORRECT EQUIPMENT AND TOOLS. Use the correct equipment and tools for the job. Do not use excessive force. Do not use electrical components that are not approved for the vehicle. Do not use electrical components that are not approved for the vehicle.

DO NOT USE ELECTRICAL COMPONENTS THAT ARE NOT APPROVED FOR THE VEHICLE. Do not use electrical components that are not approved for the vehicle. Do not use electrical components that are not approved for the vehicle.

DO NOT USE ELECTRICAL COMPONENTS THAT ARE NOT APPROVED FOR THE VEHICLE. Do not use electrical components that are not approved for the vehicle. Do not use electrical components that are not approved for the vehicle.

F

TOOLS REQUIRED:

- 1/4 in. or 3/8 in. Drive Socket Wrench
- Phillips screw driver
- Wire Cutter
- 8mm Socket
- 10 mm Socket
- 12 mm Socket
- Torque wrench
- Extension

PRE-INSTALLATION WARNINGS, CAUTIONS, CRITICAL STEPS, and NOTES:

- Dealer Installation Recommended. Instructions may refer to Service Manual.
- Installation requires special tool(s)

Vehicle Preparation:

⚠ CAUTION

- Always confirm the ignition is in the "OFF" position before changing the switch condition.

- 1) Apply parking brake
- 2) Confirm vehicle is not in the default shipping state or "Inventory position" as shown below. Failure to confirm vehicle has been removed from this state will result in loss of normal vehicle operation.
- 3) Locate Extended Storage Switch in cabin fuse block. Confirm it is in the "Customer" position. See below for reference.
 - a) To remove transit mode (Fuse Block):
 1. Remove fuse cover lid.
 2. Push down shorting pin.
 3. Ign On 2 times without starting the vehicle.
 - b) To remove transit mode (BCM):
 1. Confirm ignition switch is in "OFF" position.
 2. Simultaneously push the signal and wiper switch fully down for two (2) seconds.

NOTE: While in BCM Transit Mode, turn signal indicators will remain illuminated for one minute.

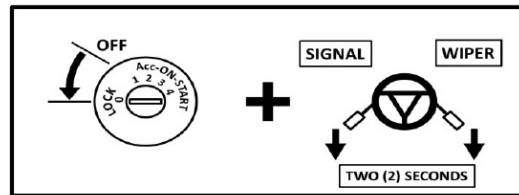
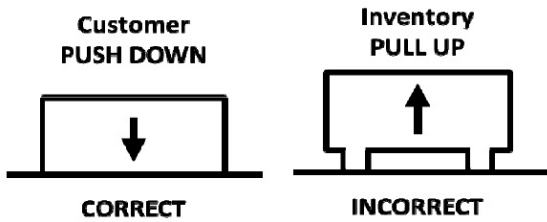

- c) To return to transit mode for storage:
 1. Ign Off.
 2. Remove fuse cover lid.
 3. Pull up shorting pin.
 4. Assemble fuse cover lid.
 5. Ign On 2 times without turn the vehicle on.
 6. Confirm transit mode condition on meter

NOTE: Typical vehicle condition shown above. Switch is easily identifiable by the permanent, push-pull fuse holder. Actual position on the fuse block may vary, vehicle to vehicle.

Condition	Switch Position	Note
Vehicle is delivered to the dealer	Inventory Condition	
Technician performs PDI	Customer Delivery	Return to Inventory position after PDI.
Customer test drives the vehicle	Customer Delivery	Return to Inventory position after test drive.
Vehicle is being stored at the dealer	Inventory Condition	
Vehicle is delivered to customer	Customer Delivery	

NOTE: The Extended Storage Switch is only an aid to improve battery life during vehicle storage at the dealer. If the Extended Storage Switch fuse ever needs service after vehicle delivery, discard the Extended Storage Switch and install the correct fuse in its place.

- 4) Turn ignition switch to "ON" position
- 5) Record the customer radio presets and other presets as required.

Preset	1	2	3	4	5	6		

- 6) Put shift lever in "P" position for A/T and CVT or "1st" for M/T
- 7) Turn ignition switch to "OFF" position
- 8) Use seat and floor protection.

INSTALLATION PROCEDURE: PRE-INSTALLATION CAUTIONS / NOTES

⚠ CAUTION

- Allow 3 min after key off and doors closed for vehicle to time out. Allow an additional 3 min after negative terminal dis-connect before separating any electrical connectors.

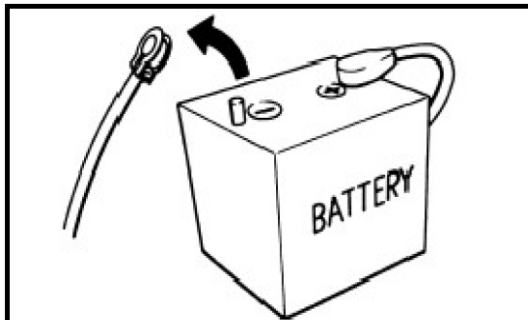

- 7) Disconnect the negative battery terminal(s).
- 8) Use seat and floor protection.
- 9) This part is to be installed at surface temperature of 65-100 deg.F.

⚠ CAUTION

- Take care not to scratch or damage any component during the removal or re-installation process.
- Trim pieces found to have witness marks or broken clips are not to be reinstalled.
- Additional items in cargo area may need to be removed.
- Always remove vehicle parts in the sequence they are shown, improper procedure can damage parts.
- Store removed parts in a safe and protected manner.

INSTALLATION OVERVIEW:

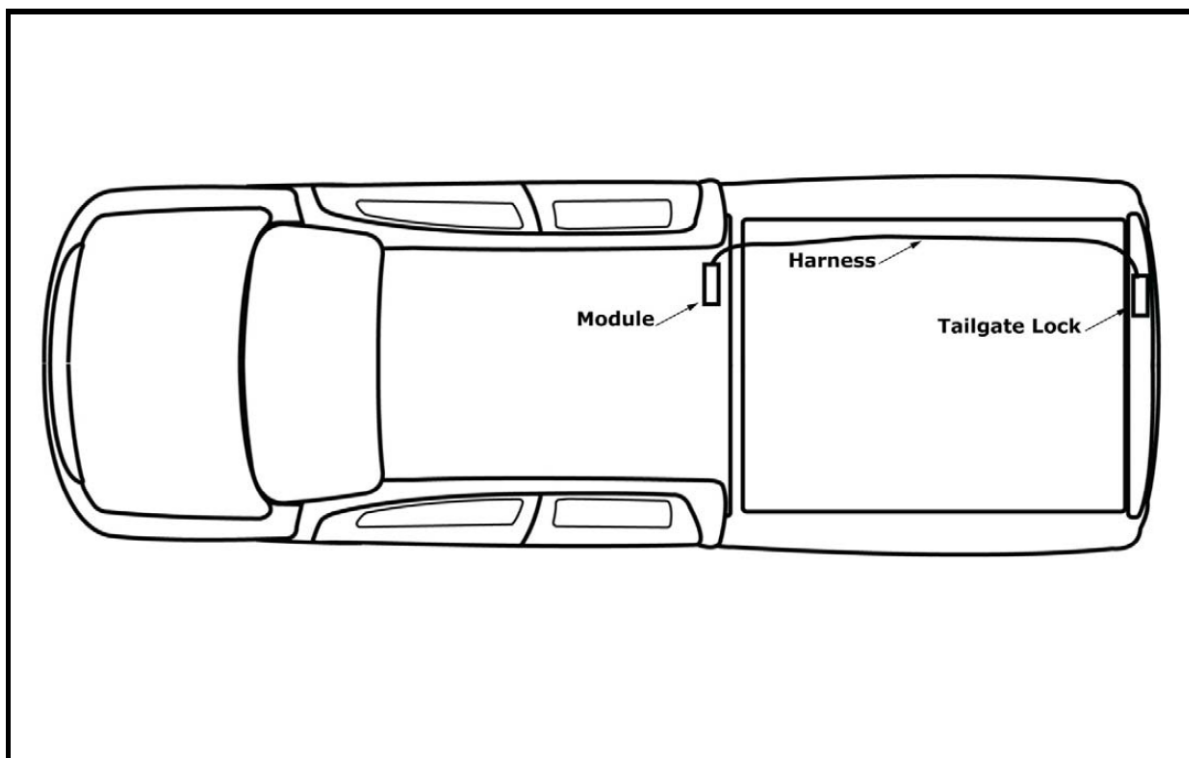

INSTALLATION PROCEDURE: (continued)

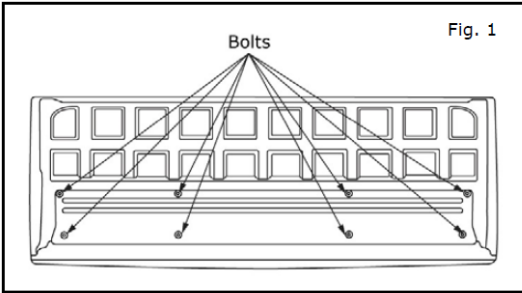

- 1) Remove 8 bolts and remove tailgate access panel. (Fig.1)

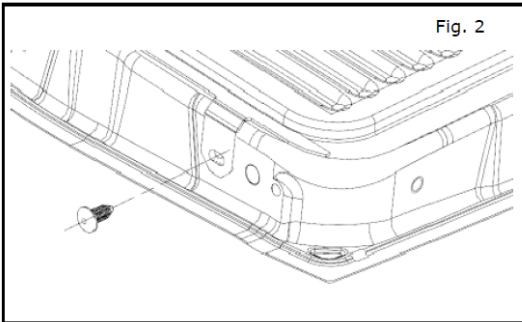

- 2) If tailgate is equipped with cover:
 - a) Remove screws as in Step 1.
 - b) Remove left and right push pin as shown in Fig.2.
 - c) Remove cover and tailgate access panel.

NOTE:

Set the cover aside with the tape facing up where the tape will not get dirty.

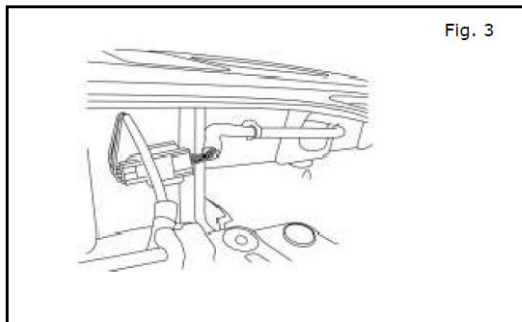

- 3) If tailgate is equipped with rear view camera, disconnect and remove camera harness 24025 EZ00A (Fig. 3) and replace with harness 24025 EZ02A. Installation in reverse of removal.

Note:

If tailgate not equipped with rear view camera, install harness 24025 EZ02A by following reverse of removal steps.

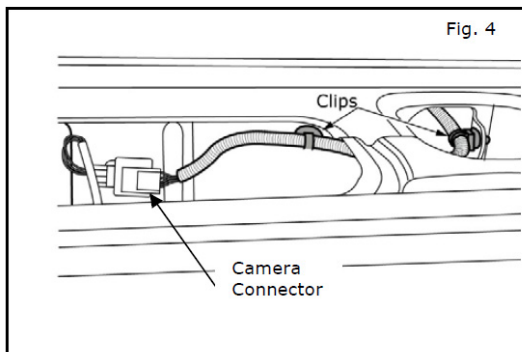

- 4) Disconnect camera connector (if equipped). Disengage 2 XMAS tree clips. (Fig.4)

INSTALLATION PROCEDURE: (continued)

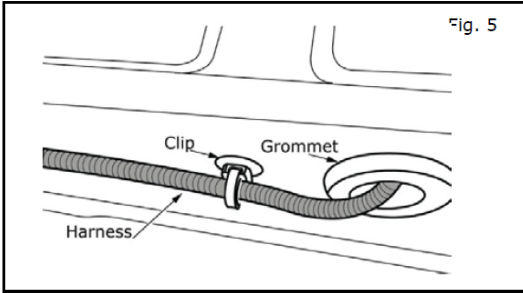

5) Disengage clip and remove grommet.

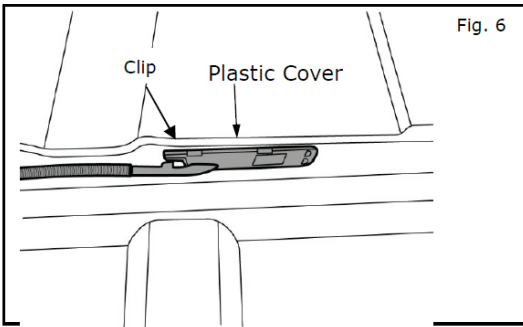

6) Unclip body side plastic cover and disengage from opening. Pull out service length and disconnect inline connector from chassis harness.

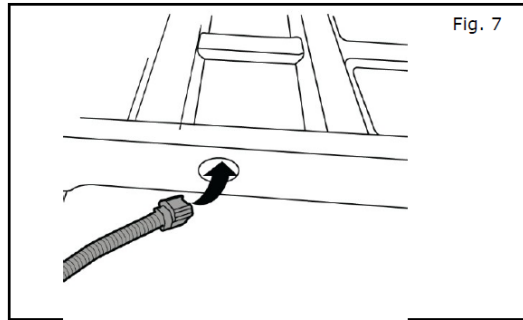

7) Remove original tailgate harness through hole under tailgate.

Replace with kitted harness 24025 EZ02A. Installation is in reverse of removal.

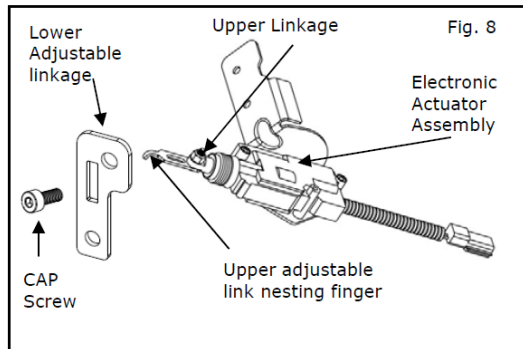

8) Installation preparation:

- a) Obtain Electronic Actuator assembly with upper adjustable linkage section attached with torque applied. (Figure 8)
- b) Obtain lower adjustable linkage section and M4 x 0.7 x 8MM long socket head. Obtain cap screw with thread lock preapplied.

Note:
Clean mating surfaces of linkages with provided alcohol wipe and avoid any further oil contamination there.

INSTALLATION PROCEDURE: (continued)

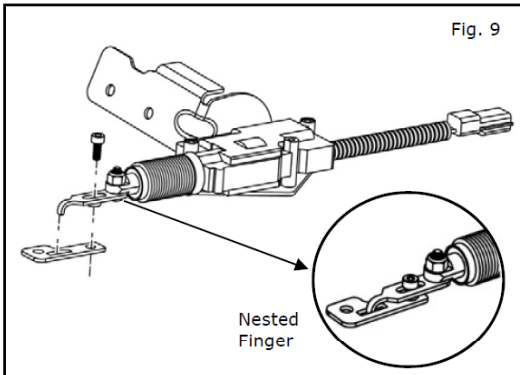

- 9) Hand assemble lower linkage to actuator assembly with provided CAP screw, finger tightening screw while allowing linkage to length adjust freely.

NOTE:

Pay special attention to orientation of the lower adjustable linkage. The nut will be pointing upward. The nesting finger in the upper actuator link is installed into the slot in the lower link as shown. (Figure 9) This assembly can be done off the vehicle.

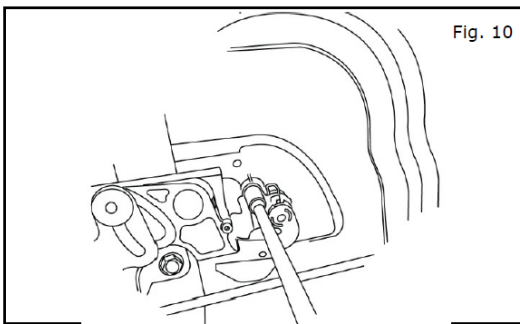

- 10) Install Electronic Actuator assembly onto Key Cylinder lock-rod:

- a) Using 10mm socket and extension, remove key cylinder lock screw. (Figure 10)
- b) Tilting key cylinder lock-rod off alignment peg, remove from slotted plastic tailgate lock lever arm, for ease of installation of electronic actuator. (Figure 10-B)

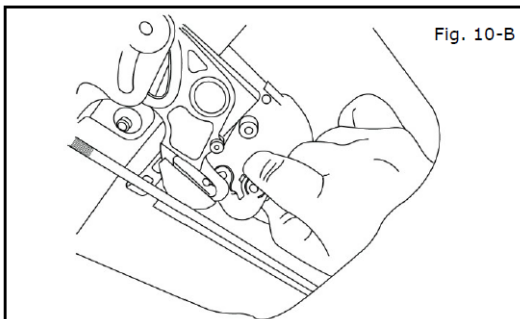

- c) Loosely position actuator link into position between bottom of plastic tailgate lock lever arm and top of key cylinder lock-rod, then reposition key lock cylinder into tailgate handle mechanism and hand tighten key cylinder lock screw.

NOTE:

Pay special attention to orientation of linkage. Ensure M4 socket head CAP screw is pointing outward, so adjustable linkages can be operator adjusted and tightened, as shown (Figure 10-C) All of these features should be visible to the installer

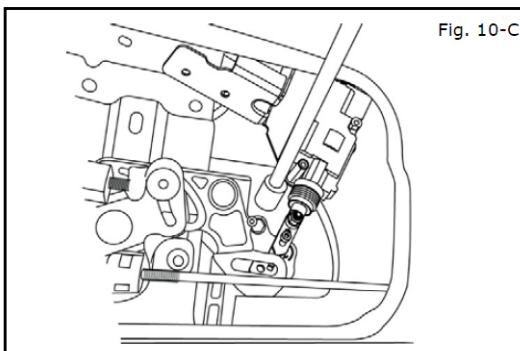

NOTE:

Allow the actuator to lay in the tailgate rotated about 45° CW from its final installation location so that you can install the key lock cylinder and tighten its fastener.

- d) With key cylinder lock-rod in position, torque M5 screw to (5-6.5 Nm) using 10mm socket and extension (Figure 10-C).

INSTALLATION PROCEDURE: (continued)

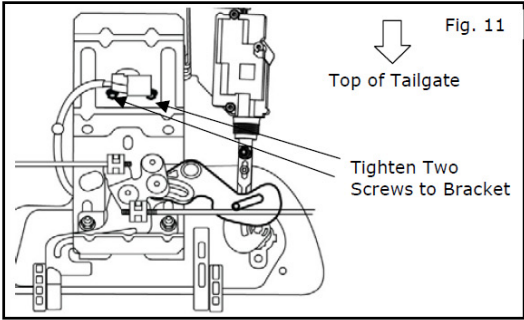

11) **Mounting Electronic Actuator:**

- a) Position actuator bracket CCW under tailgate bracket. Ensure holes on actuator bracket are aligned with predrilled holes on tailgate bracket.
- b) Install two M5 screws to bracket using 8mm swivel socket. Tighten screws to (3.2 - 4.8 Nm.) (Figure 11)

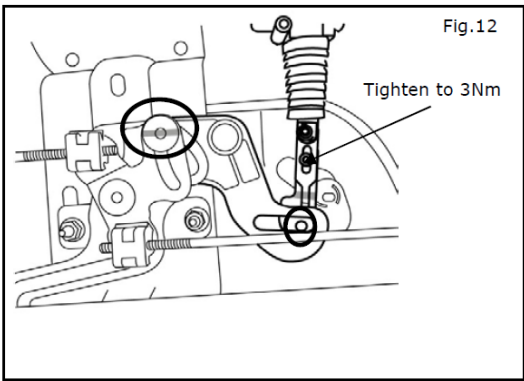

- 12) Move key cylinder lock pin by hand to unlock position (Actuator **FULLY** extended) and allow linkage to rest there.

Notice:

Key cylinder lock pin should fully reach into the far right most upper corner of plastic tailgate lock lever arm, and actuator linkage should fully reach unlock position (as shown) and stay there in a relaxed state. (Figure 12)

Hold lever arm in place lightly to tighten M4 CAP screw with a 3MM Hex bit socket driver to (3 Nm +/- 0.5 Nm). (Figure 12).

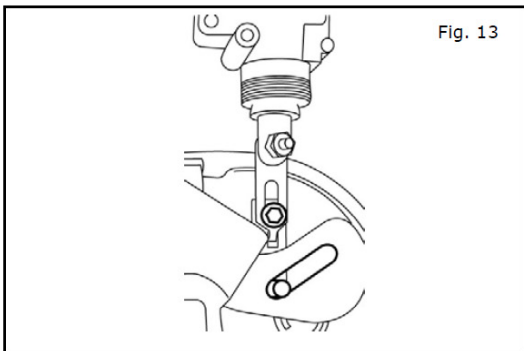

- 13) Return key cylinder lock pin with the key to **lock** position (Actuator **NOT extended**) and let it rest there.

Notice:

The pin should fully reach into the left most corner of the plastic tailgate lock lever arm as shown, and stay there in a relaxed state. (Figure 13)

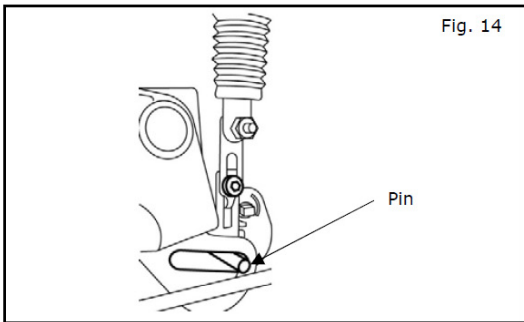

- 14) Move key cylinder lock pin with the key to **unlock** position (Actuator **FULLY extended**) and let it rest there.

Notice:

The pin should again fully reach into the right most upper corner of the plastic tailgate lock lever arm as shown. (Figure 14)

INSTALLATION PROCEDURE: (continued)

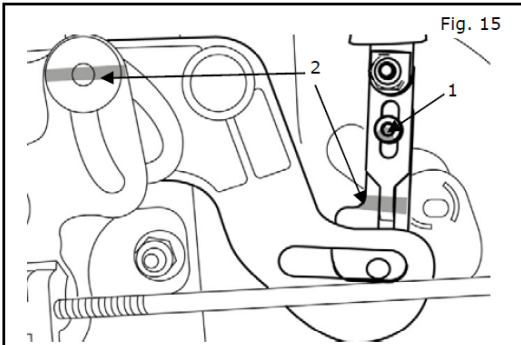

- 15) Cycling with the **key** between unlock position (Actuator **FULLY extended**) and lock position (Actuator **NOT extended**). It should function easily and fully.

Key cylinder lock pin should easily traverse and then rest between (**Unlock = Actuator FULLY extended**) in right most corner of plastic tailgate lock lever arm, and (**Lock = Actuator NOT extended**) with plastic tailgate lock lever arm reaching into left most corner of plastic tailgate lock lever arm.

Notice: Once the alignment is completed:

- 1) The paint mark indicating the M4 CAP screw was torqued as specified.
- 2) Apply paint mark in a manner that bears a witness mark for the position/relationship of both parts at the time of assembly. (Figure 15)

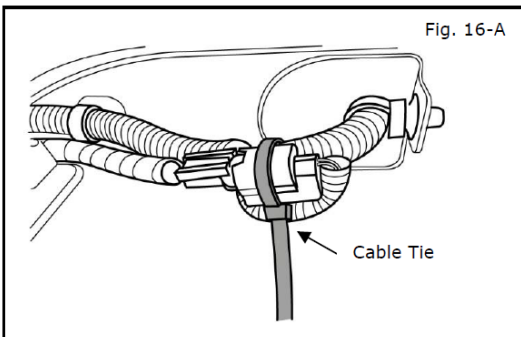

- 16) Connecting harness to actuator.

- a) Connect mating connector on tailgate actuator and secure harness with 8" cable tie. (Fig 16-A)

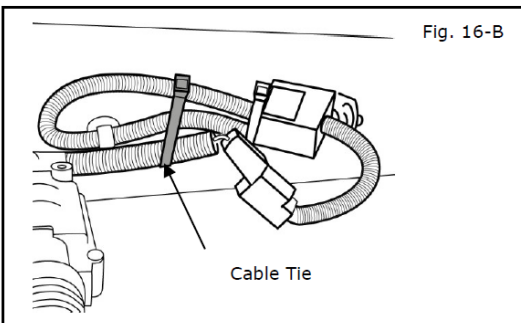

- b) If tailgate is not equipped with rear view camera, bend camera harness back and secure with cable tie to actuator harness as shown. (Fig. 16-B)

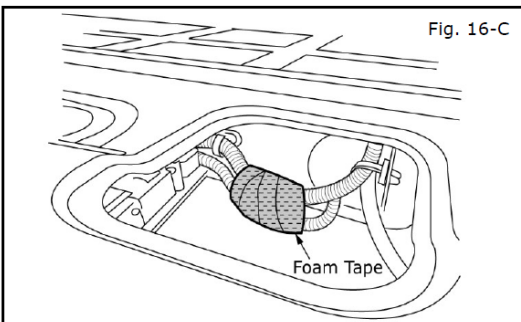

- c) Foam tape inline connectors, to prevent rattle within tailgate. (Fig. 16-C)

INSTALLATION PROCEDURE: (continued)

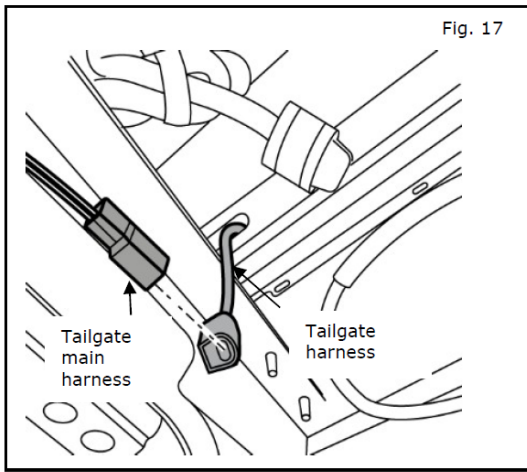

- 17) Connect tailgate harness(24025 EZ02A) to the kit provided tailgate main harness (999M2 W3002). (Figure 17)

NOTE:

- Do not secure either tailgate harness (24025 EZ02A) or kit provided tailgate main harness (999M2 W3002) for the first (200 mm = 8 inches) to the vehicle. Wire harness ends must be able to exist in vehicle if customer removes tailgate in normal operation. Length is required to allow customer to access connector from above
- Secure inlines so they don't hang or bang around underbody.
- Do not foam tape inline connectors.

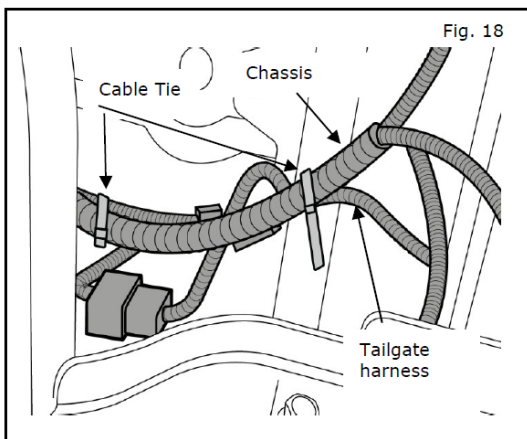

- 18) Cable tie harness to vehicle chassis harness using two 8" cable ties. (Figure 18)

Note:

- Route main harness along chassis harness as shown in fig 24a. Only up until the back of the cab near the grommet.
Do not secure with wire ties until step 24.**

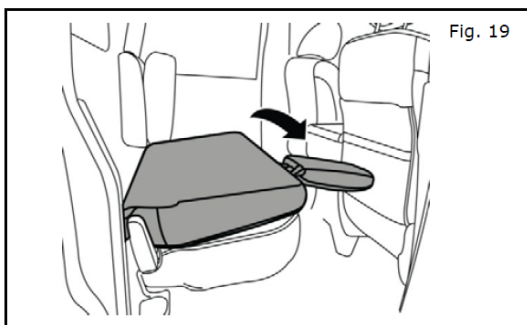

- 19) Fold down rear passenger seat.

INSTALLATION PROCEDURE: (continued)

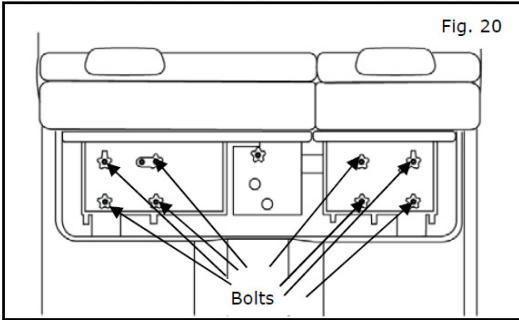

20) Standard Cab Vehicles Only:
Remove under seat storage box.

- a) Remove under seat storage box by loosening 8 bolts using 10mm socket.

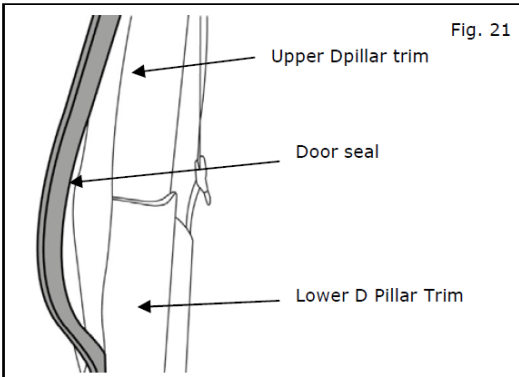

21) Remove door trim seal and trim.

- a) Unclip lower D pillar trim. (Fig 21)
- b) Pull section of rear passenger door seal out and lose up the trim panel. (Fig 21)
- c) Unclip upper D-pillar trim. (Fig 21)

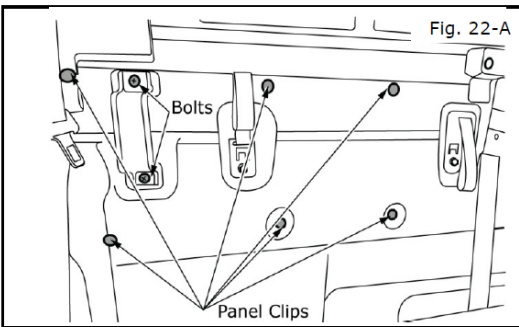

22) Accessing harness pass through hole.

- a) Remove 6 pc panel clip and 2 bolts using 12mm socket. (Figure 22-A)
- b) Pull back panel for access to hole location with plastic grommet on rear of cab on lower passenger side. (Figures 22-A and 22-B)

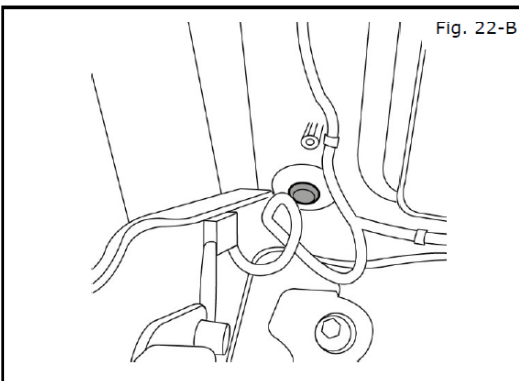

- c) Remove plastic grommet. (Figure 22-B)

INSTALLATION PROCEDURE: (continued)

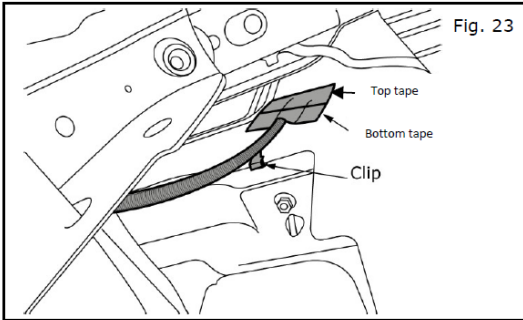

23) Route harness into cab.

- a) Run tailgate main harness with plastic grommet into cab. Ensure blue tape on harness is lined up with grommet.
- b) Clean surface with alcohol wipe and apply two blue tapes to cover grommet and harness. Apply bottom tape first then top tape on top of bottom tape. Make sure tape is covering entire grommet.
- c) Install edge biter clip to body panel to secure harness. (Figure 23)

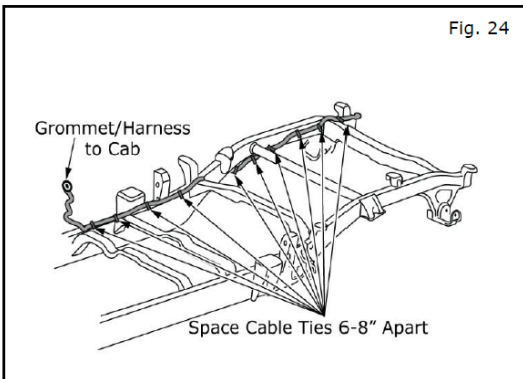

24) Securing tailgate main harness to chassis harness.

- a) Cable tie tailgate main harness every 6-8" to chassis harness. (Figure 24)

Begin at front, stop at position above rear suspension, then from rear and continue to step "b" below.

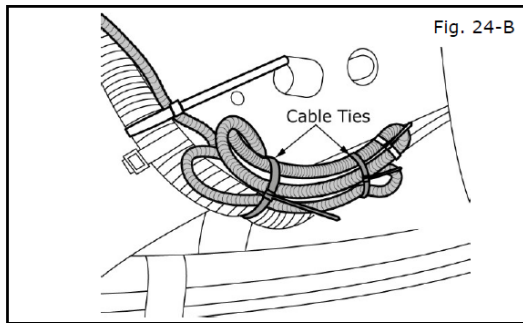

- b) Bundle excess harness above rear suspension to 6"-8" length and cable tie to chassis harness with two 12" zip ties. Trim excess zip tie. (Figure 24-B)

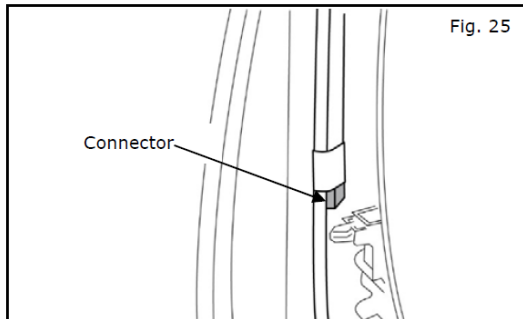

25) Locate vehicle pre wired connector behind upper D-pillar trim and break grey than cut black tape to pull down connector. (Figure 25)

NOTE:

It is easier to get to the connector from the back of the trim.

INSTALLATION PROCEDURE: (continued)

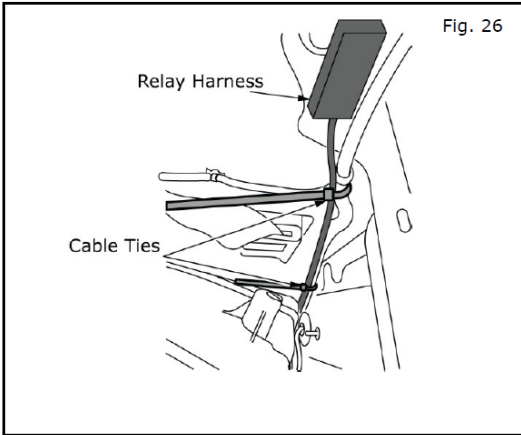

26) Connecting relay harness to tailgate main harness.

- a) Connect relay harness 999M2 W3003 connector (white NS03) to tailgate pre wire connector (white NS03). Foam tape inline connectors before securing harness with cable ties. (Figure 26)
- b) Wire tie harness to vehicle harness.
- c) Trim off excess wire tie.

Note:

Ensure harness is routed all the way to the floor of the vehicle to clear the plastic trim and the seat bracket.

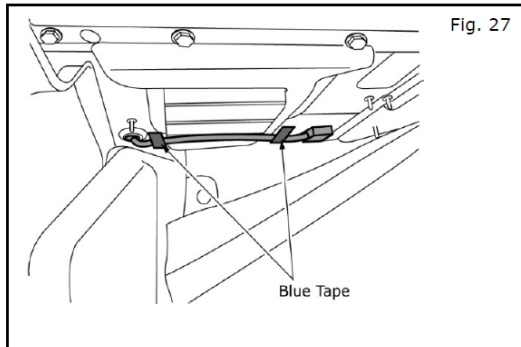

27) Connect relay harness to tailgate main harness.

- a) Connect relay harness 999M2 W3003 connector (Black RH02) to tailgate main harness connector (Black RH02).
- b) Peel back tape on relay and adhere relay to body panel. Apply 15 lbs. pressure for 30 seconds.
- c) Foam wrap connector before taping and secure with blue tape. (Figure 27)

Notes:

1) Some vehicles will have a harness in the same location. If another harness is present, use 8" wire tie to secure harness instead of blue tape. (Figure 28)

2) Ensure cable running to vehicle pre-wire connector remains at the floor in the area near the seat hinge and the lower D-Pillar trim.

3) Cut all cable tie ends.

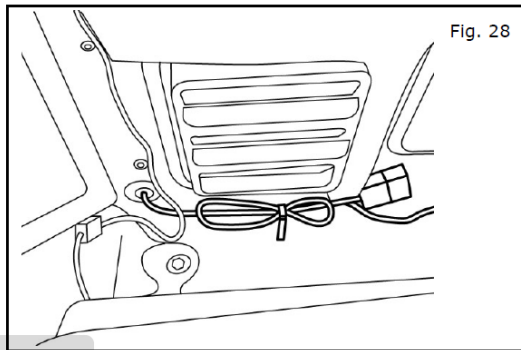

FINAL INSPECTION:

- Functional check system
 - Press key fob to lock and check tailgate is locked.
 - Press key fob to unlock all doors and check that tailgate is unlocked.
 - If vehicle is equipped with rear view camera. Check rear camera is functional.
- Reinstall back panel and 6pc push clip. See Figure 22-A.
- Reinstall bracket and tighten 2 pcs bolt to (20.6 - 26.5 Nm). See Figure 22-A.
- Reinstall upper trim panel and door seal and lower panel. See Figure 21.
- If this is a Standard Cab vehicle: Reinstall rear underseat storage bin. See Figure 20.
- Reinstall tailgate access panel and rubber panel if applicable and tighten 8 screws to 1.7-2.0Nm. See Figures 1 and 2.

Tailgate Lock

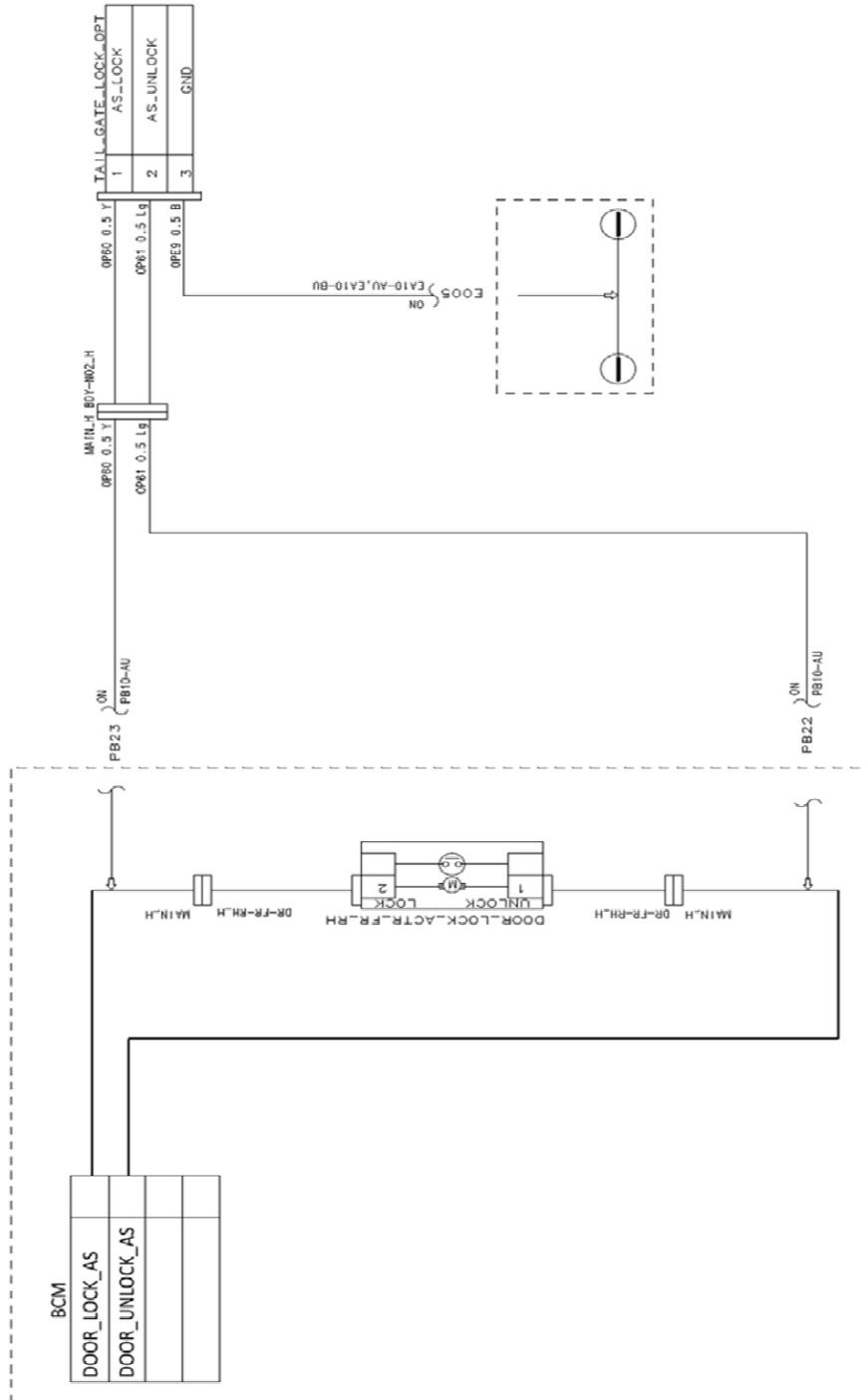

CLAIMS INFORMATION

Submit a Campaign (CM) line claim using the following claims coding:

CAMPAIGN (CM) I.D. #	DESCRIPTION	OP CODE	FRT
PC466	Install electronic tailgate lock	PC4660	0.7 hrs.

