



SERVICE BULLETIN

Classification: EL16-033	Reference: NTB16-089	Date: September 8, 2016
-----------------------------	-------------------------	----------------------------

2016 TITAN XD; HEADLAMP AIMING

APPLIED VEHICLE: 2016 Titan XD (A61)

SERVICE INFORMATION

When adjusting the headlamps on a Titan XD, make sure to follow the procedures in the Electronic Service Manual (ESM).

- Warranty claims for headlamp adjustment are subject to audit.
- Claims must have the measurements for dimension **A**, **B**, and **C** (shown in this bulletin) listed on the repair order and on the Technician Comments line of the claim.
- Claims submitted without these measurements may be denied.

If a customer reports their headlamps are not aimed correctly:

1. Determine the type of headlamp equipped on the vehicle (Halogen or LED).
 - The ESM contains two headlamp adjustment procedures. **Make sure to use the correct procedure:**
 - **Halogen headlamp adjustment , or**
 - **LED headlamp adjustment**
2. Follow the exact procedure in the ESM for headlight adjustment.

CAUTION: Do not deviate from the adjustment procedure in the ESM.

3. Refer to the Clarifications of the ESM Vertical Headlamp Adjustment Procedures in this bulletin.

Nissan Bulletins are intended for use by qualified technicians, not 'do-it-yourselfers'. Qualified technicians are properly trained individuals who have the equipment, tools, safety instruction, and know-how to do a job properly and safely. **NOTE:** If you believe that a described condition may apply to a particular vehicle, DO NOT assume that it does. See your Nissan dealer to determine if this applies to your vehicle.

Clarifications of the ESM Vertical Headlamp adjustment Procedures

NOTE: Go to page 5 for LED headlamps.

Halogen Headlamps

1. If equipped with a manual headlight aiming control, make sure it is set to "0".

Manual headlamp aiming control set to "0"



Figure 1

2. Place the vehicle 7.6 m (25 ft) from the screen (see dimension **E** in Figure 2).

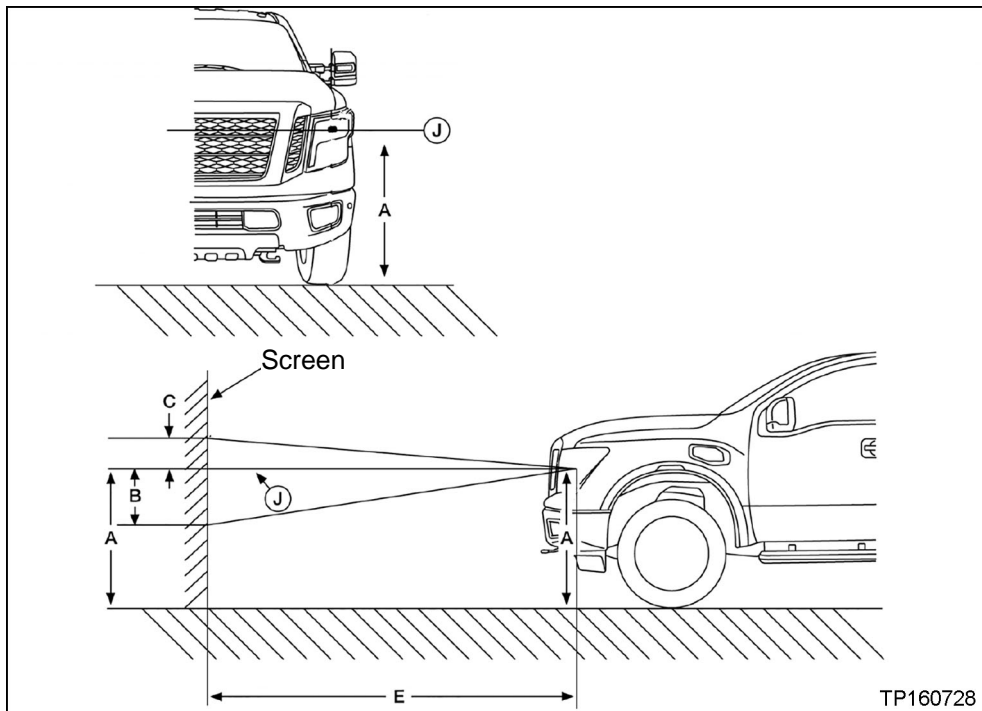

Figure 2

TP160728

3. Measure dimension **A** in Figure 3.

- Measure the distance from the center of the headlamp low beam bulb (**J**) to the ground.

Write this measurement (A) on the repair order and on the Technician Comments line of the warranty claim.

4. Use the measurement from step 3 to make a horizontal mark/line on the screen.

- This is represented as **J** on the screen in Figure 3.

Example: If the measurement **A** in step 3 is 42 inches (106.7 cm), make a horizontal line on the screen 42 inches (106.7 cm) above the ground.

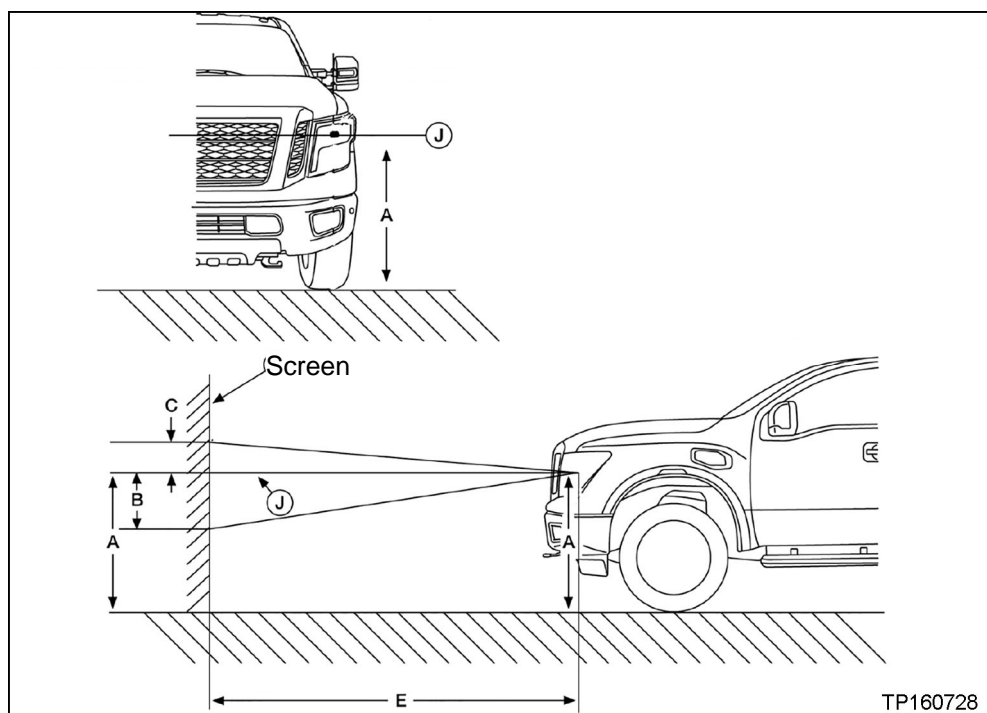
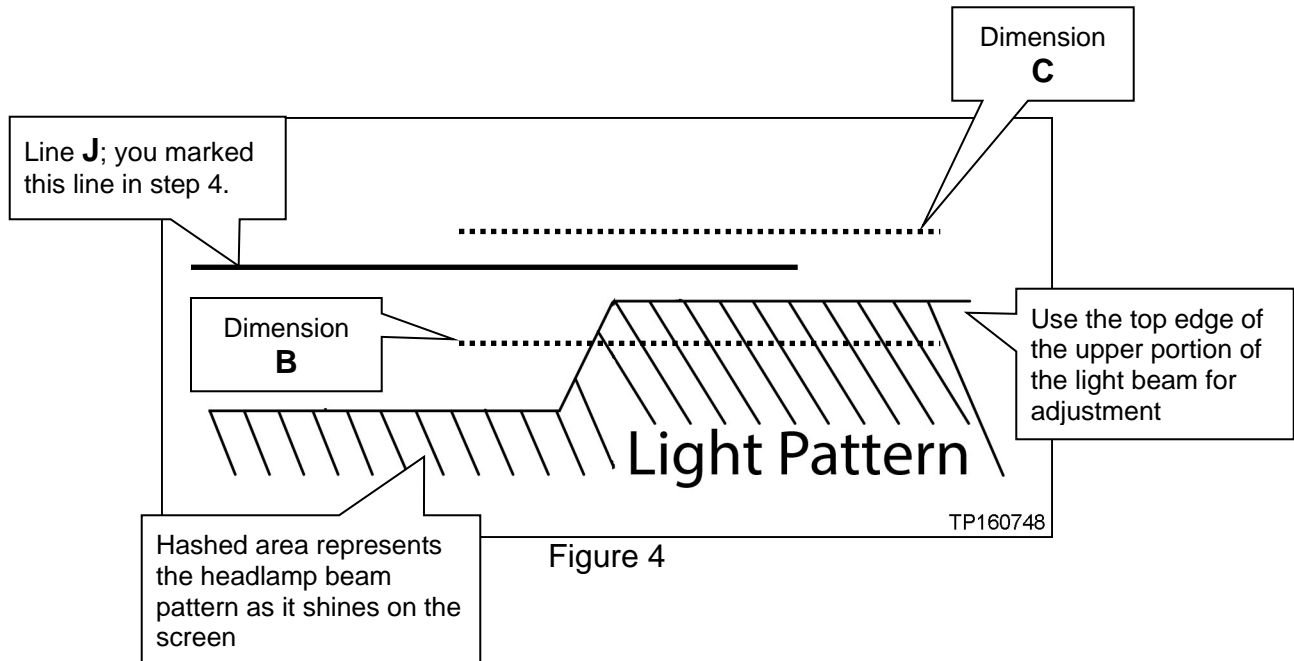

Figure 3

5. Turn the headlamps ON, set to low beam and block one beam.
6. Figure 4 represents one headlamp beam as it shines on the adjustment screen.
7. Follow the instructions in the ESM to perform adjustment within the range limits of dimension **B** and **C** in Figure 4. (Also refer to Figure 3 on the previous page.)



- Dimension **B** is the minimum cutoff line height; the lowest point at which the headlamp may be adjusted: 53.2 mm (2.1 inch) below line J.

**Write on the repair order and on the Technician Comments line of the warranty claim the headlamp adjustment measurement (B).
Record measurement before and after adjustment.**

- Dimension **C** is the maximum cutoff line height; the highest point at which the headlamp may be adjusted: 13.2 mm (0.5 inch) above line J.

**Write on the repair order and on the Technician Comments line of the warranty claim the headlamp adjustment measurement (C).
Record measurement before and after adjustment.**

LED Headlamps

NOTE: Go to page 2 for Halogen headlamps.

1. If equipped with a manual headlamp aiming control, make sure it is set to "0".

Manual headlamp aiming control set to "0"



Figure 5

2. Place the vehicle 7.6 m (25 ft) from the screen (see dimension **E** in Figure 6).

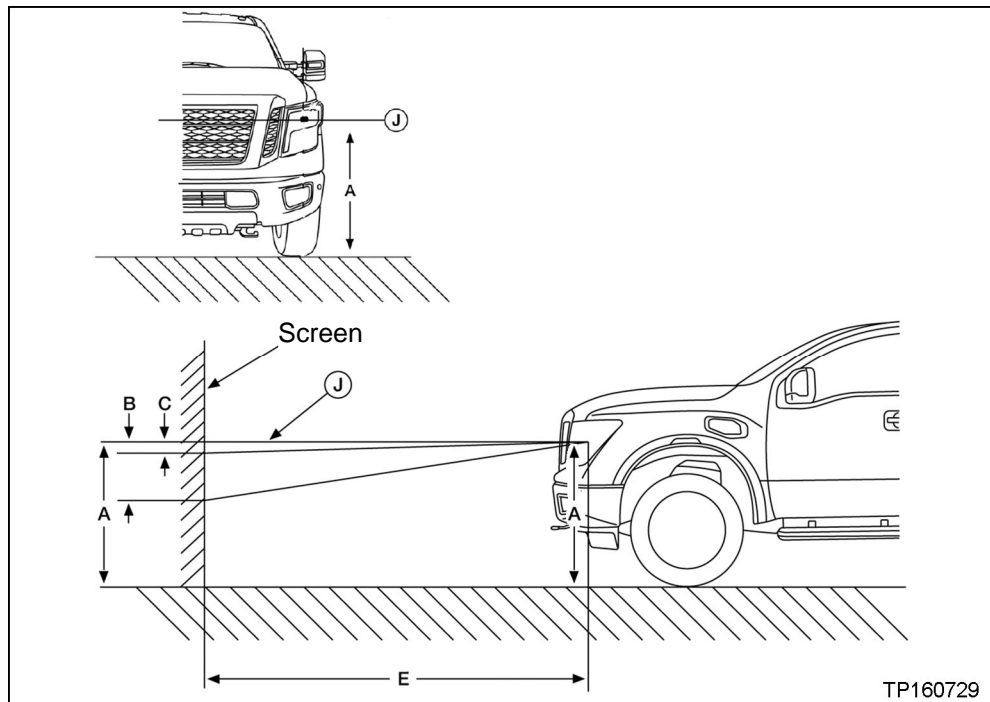

Figure 6

3. Measure dimension **A** in Figure 7.

- Measure the distance from the center of the headlamp low beam bulb (**J**) to the ground.

Write this measurement (A) on the repair order and on the Technician Comments line of the warranty claim.

4. Use the measurement from step 3 to make a horizontal mark/line on the screen.

- This is represented as **J** on the screen in Figure 7.

Example: If the measurement **A** in step 3 is 42 inches (106.7 cm), make a horizontal line on the screen 42 inches (106.7 cm) above the ground.

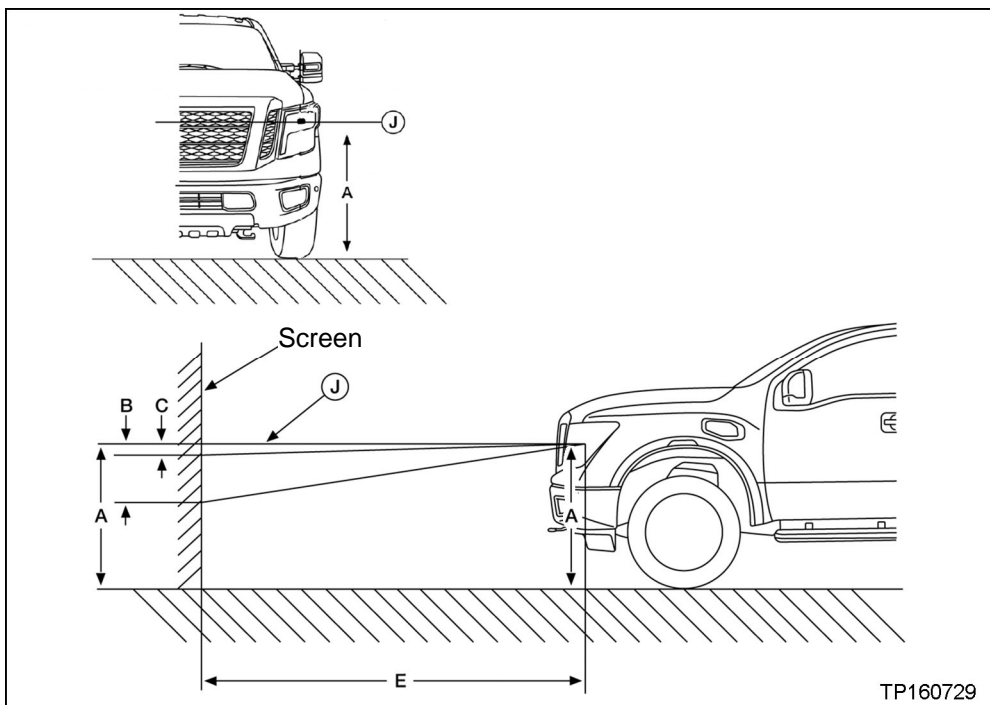
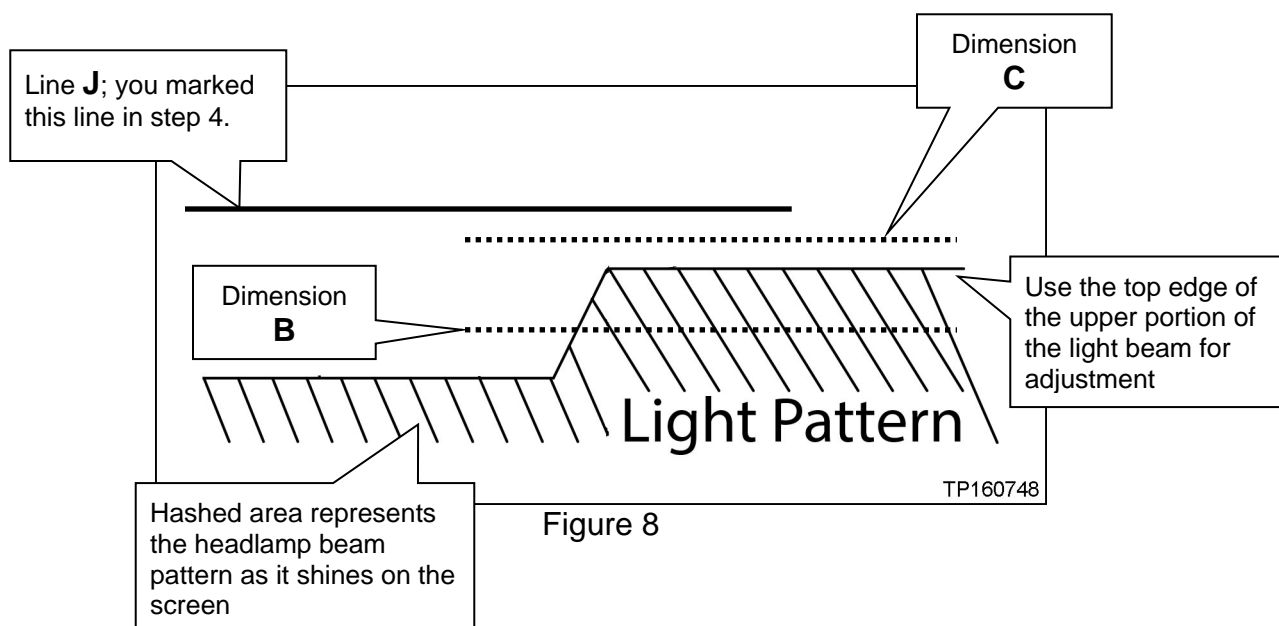

Figure 7

5. Turn the headlamps ON, set to low beam and block one beam.
6. Figure 8 represents one headlamp beam as it shines on the adjustment screen.
7. Follow the instructions in the ESM to perform adjustments within the range limits of dimension **B** and **C** in Figure 8. (Also refer to Figure 3 on the previous page.)



- Dimension **B** is the minimum cutoff line height; the lowest point at which the headlamp may be adjusted: 93.1 mm (3.7 inch) below line J.

**Write on the repair order and on the Technician Comments line of the warranty claim the headlamp adjustment measurement (B).
Record measurement before and after adjustment.**

- Dimension **C** is the maximum cutoff line height; the highest point at which the headlamp may be adjusted: 13.3 mm (0.5 inch) below line J.

**Write on the repair order and on the Technician Comments line of the warranty claim the headlamp adjustment measurement (C).
Record measurement before and after adjustment.**