

# Technical Service Bulletin



## 46 Squeal from front brakes

46 16 47 2042182/4 July 12, 2016. Supersedes Technical Service Bulletin Group 46 number 16-39 dated May 31, 2016 for reasons listed below.

Model(s)	Year	VIN Range	Vehicle-Specific Equipment
Q5	2013	047567 - 999999	2.0 and 3.0 engines
Q5	2014 - 2017	All	2.0 and 3.0 engines

## Condition

REVISION HISTORY		
Revision	Date	Purpose
4	-	Revised <i>Service</i> (Updated embedding procedure) Revised <i>Warranty</i> (Updated claim type)
3	5/31/2016	Revised <i>Service</i> (Added image, added information about pad installation direction)
2	4/4/2016	Revised <i>Service</i> (Added image, added information about PR codes) Revised <i>Required Parts and Tools</i> (Added balance weight)

Customer reports hearing a squeal noise from the front brakes in the following conditions:

<b>When:</b>	During first brake application in the morning, with cold brakes
<b>Speed:</b>	Below 20 mph
<b>Temperature:</b>	Below 40°F
<b>Conditions:</b>	High humidity



**Tip:** For an example of the sound, see the video located at: <https://audi-external.kzoplatform.com/swf/player/314> (Figure 1).



*Figure 1.* QR code for viewing the video with a QR code reader on phones and tablets. Alternatively, the video can be accessed through computer internet browsers at the link provided in this bulletin.

## Technical Background

Not applicable.

## Production Solution

Not applicable.

## Service

Before proceeding, check the following table to confirm that this bulletin applies.

Model	Model years	Front brakes (Brembo) disc size
Q5 2.0T (non-hybrid)	2013 to 2017: All	320 x 30 mm
Q5 3.0T (without SQ5)	2013 to 2017: All	345 x 30 mm
Q5 TDI	2014 to 2017: All	345 x 30 mm



**Note:**

- This TSB only applies to Q5 models listed in the table above.

# Technical Service Bulletin



- This TSB applies only to vehicles produced after 12/10/2012 (SVM code will only be accepted after production date of 12/10/2012).
- This TSB *does not* apply to Q5 models built before 2013 and does not apply to hybrid or SQ5 models (due to different front brakes).



**Tip:** Rust/corrosion build-up, grooves, or glazing on the braking surface of the brake disc may cause brake noise and must be considered when replacing brake pads. Brake discs that are worn close to the wear limit or that are at the wear limit may also contribute to brake noise.

1. Replace the front brake pads according to the instructions in Elsa at: *Repair manual >> Chassis Brake System >> 46 Mechanical Components >> Front Brakes >> Brake Pads, Removing and Installing, Brake 1LB and 1LC or Brake Pads, Removing and Installing, Brake 1LE and 1LP.*



## Note:

- Some vehicles may have two shims glued to the back of the front brake pads (Figure 1). **Do not** transfer these shims to the new pads.
- New brake pads have an adhesive backing that should be used to properly attach the pads to the caliper.
- For 3.0 TFSI/TDI only: Brake pads have an arrow that indicates the correct installation position in the caliper. The pads should be installed with the arrows following the forward rotation of the wheel (Figure 2).

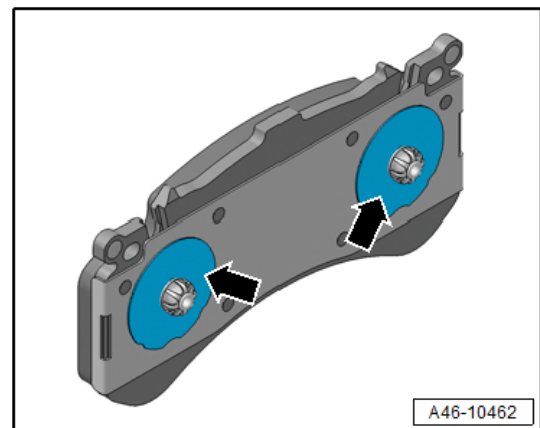

**Figure 1.** Shims on back of front brake pads.



**Figure 2.** Directional arrow on the back of front brake pad.

The following steps must be followed to ensure proper installation of the pads:

- Thoroughly clean and dry each piston (Figure 3, arrows) to ensure that the new pads will properly adhere to the pistons.
- Do not apply any lubricants to the pads or calipers.
- After the pads are installed in the calipers, apply full pedal pressure for at least 10 seconds to ensure proper adhesion of the pads to the pistons.
- In order to allow the glue to set, do not drive the vehicle for 10 minutes after new pads have been installed.

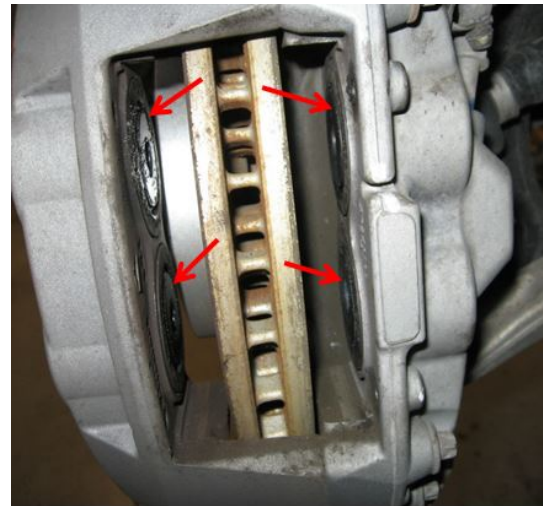

**Figure 3.** Location of pistons.

2. Replace the rear brake pads according to the instructions in Elsa at: *Repair manual >> Chassis Brake System >> 46 Mechanical Components >>Rear Brakes>>Removing and installing brake pads.*

For vehicles that require balance weight (3.0 TFSI and TDI):

The balance weight should be assembled in the upper position near the parking brake electric motor connector (Figure 4).



**Figure 4.** Balance weight position.

# Technical Service Bulletin



### 3. Brake embedding:

- A. Perform 10 stops from approximately 35 mph to 10 mph with medium pedal pressure.
- B. Drive for approximately 2 minutes at approximately 40 mph without braking to allow the brakes to cool down.
- C. Repeat steps A and B if necessary.



#### Note:

Do not perform ABS stops as a way of embedding the brakes. Brake pads and discs may be permanently damaged if brakes are overheated prior to being properly embedded.

### 4. Perform SVM update with the following code: **03A014**

This update changes the ABS/ESP software due to the new brake pad compound and changes the vehicle PR number to help in identifying and tracking vehicles with new parts. After the SVM update, this TSB will not show up for this VIN in ELSA due to the PR number change. (See table below.)

Model	Actual PR Number – Front Brakes	Target PR Number – Front Brakes
Q5 2.0 TFSI	1LB	1LC
Q5 3.0 TFSI/ 3.0 TDI	1LE	1LP

### SVM Update Instructions

1. Follow all instructions in the attached TSB 2011732 *00 Software Version Management (SVM), operating instructions*.
2. Update the vehicle using the SVM action code as listed in the table below.

Model	Old Software Part Number	Old Software Version	New Software Part Number	New Software Version	SVM Code Input
Q5 2.0T / 3.0T/ 3.0TDI	8R0907379AS	0020	8R0907379BG	0030	03A014
Q5 2.0T / 3.0T/ 3.0TDI	8R0907379AM	0030	8R0907379BG	0030	03A014
Q5 2.0T / 3.0T/ 3.0TDI	8R0907379AL	0040	8R0907379BG	0030	03A014

# Technical Service Bulletin



## Warranty

<b>Claim Type:</b>	<ul style="list-style-type: none"> <li>• 110 up to 48/50</li> <li>• If vehicle is outside any warranty, this Technical Service Bulletin is informational only.</li> </ul>		
<b>Service Number:</b>	4636		
<b>Damage Code:</b>	0010		
<b>Labor Operations:</b>	Wheels remove+reinstall (front)	4405 2000	20 TU
	Wheels remove+reinstall (rear)	4405 2000	20 TU
	Brake pads, front remove+reinstall	4636 2050	50 TU
	Brake pads, rear remove+reinstall	4638 2050	50 TU
<b>Diagnostic Time:</b>	GFF and software update	0150 0000	Time stated on diagnostic protocol (Max 60 TU)
	Road test prior to service procedure	0121 0002	10 TU
	Road test after service procedure	0121 0004	10 TU
	Technical diagnosis at dealer's discretion (Refer to Section 2.2.1.2 and Audi Warranty Online for DADP allowance details)		
<b>Claim Comment:</b>	As per TSB #2042182/4		

All warranty claims submitted for payment must be in accordance with the *Audi Warranty Policies and Procedures Manual*. Claims are subject to review or audit by Audi Warranty.

## Required Parts and Tools

Part Number	Part Description	Quantity
8R0698151H (3.0 TFSI & TDI)	1 set of front brake pads	1
8R0698151K (2.0 TFSI)	1 set of front brake pads	1
8K0698451D (3.0 TFSI & TDI)	1 set of rear brake pads	1
WHT 001 921	Balance weight with hexagon bolt	2
8K0698451C (2.0 TFSI)	1 set of rear brake pads	1
Check ETKA for applicable part number	Contact (wear sensor)	1

## Additional Information

All parts and service references provided in this TSB (2042182/1) are subject to change and/or removal. Always check with your Parts Department and service manuals for the latest information.