

# Technical Service Bulletin



## 46 A6 and A7 squealing from front brakes (PR-1LJ)

46 16 38 2040964/3 May 24, 2016. Supersedes Technical Service Bulletin Group 46 number 15-24 dated October 14, 2015 for reasons listed below.

Model(s)	Year	VIN Range	Vehicle-Specific Equipment
A6, A7	2014 - 2015	All	With PR code 1LJ

## Condition

REVISION HISTORY		
Revision	Date	Purpose
3	-	Revised <i>Required Parts and Tools</i> (Added brake disc option)
2	10/14/2015	Revised header data (Removed VIN breaks) Revised <i>Production Solution</i> (Completely revised) Revised <i>Service</i> (Added steps) Revised <i>Warranty</i> (Added 4636 2050 labor operation) Revised <i>Required Parts and Tools</i> (Added brake pads)
1	6/29/2015	Initial publication

Customer may complain about brake squeak or squeal with light to moderate pedal pressure.

## Technical Background

If any of the following conditions exist, this TSB does not apply.

1. Front brake discs or brake pads are close to their wear limit (disc wear limit: 28 mm and pads wear limit with backing plate and dampening plate: 10 mm).
2. Foreign objects between brake disc and brake pad, such as small stones, grit, rust build-up, or sand.
3. Un-ground or corroded friction materials.
4. Metallic deposits from disc material in brake pad (Figure 1).



*Figure 1. Metallic deposits.*

## Production Solution

Multiple unique improvements were released.

## Service

1. Replace front brake pads with updated brake pads (part number 4G0698151K) according to Elsa.
2. Apply a thin coat of anti-seize (G 052560A2) lubricant to the guide pins of the front caliper carriers (Figure 2).

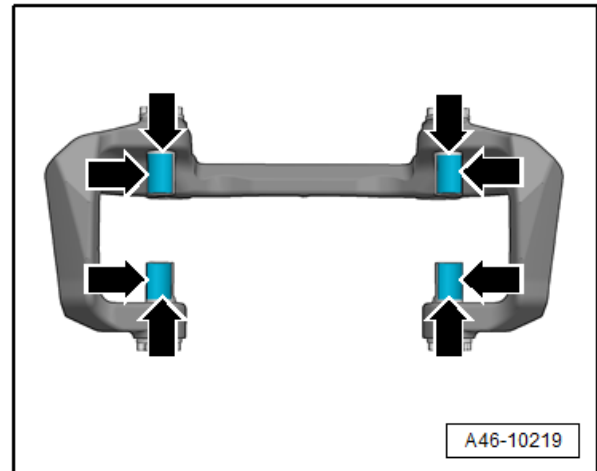
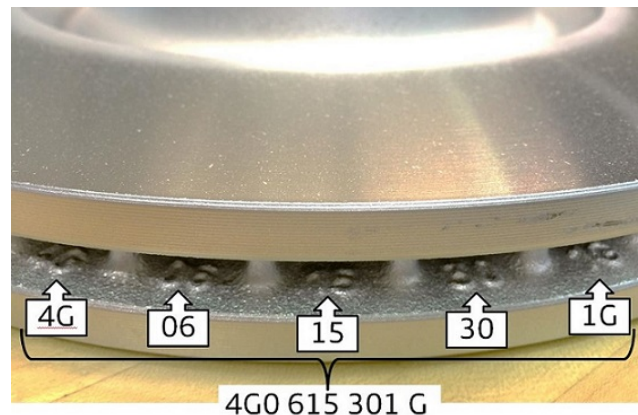

**Figure 2.** Caliper carrier guide pins with anti-seize (G 052560A2) lubricant applied where the pads make contact.

3. Check the part number on the front discs. If the part number is not 4G0615301G, then install 4G0615301G or 4G0615301Q front discs, or any supersession available in ETKA (Figure 3).



**Tip:** Replacing front brake discs on cars that already have part number 4G0615301G installed will not resolve the noise complaint and will not be covered under warranty.



**Figure 3.** Front brake disc part number location.

## Brake embedding

1. Perform 10 stops from approximately 35 mph to 10 mph with medium pedal pressure.
2. Drive for approximately 5 minutes without braking to allow the brakes to cool down.

# Technical Service Bulletin



3. Perform 10 stops from approximately 35 mph to 10 mph with medium pedal pressure.
4. Drive for approximately 5 minutes without braking to allow the brakes to cool down.
5. Repeat steps 1 and 2 if necessary.
6. Do not perform ABS stops as a way of embedding the brakes. Brake pads and discs may be permanently damaged.



**Tip:** If the vehicle still exhibits brake noise after all the repairs stated above have been accurately performed:

- Obtain a sound recording, create a TAC ticket, and attach the sound recording.
- Do not open a TAC ticket without a sound recording.

## Warranty

There must be an original customer complaint of the specified symptom on the repair order for this Technical Service Bulletin to apply. Adding this procedure on is not permitted.

<b>Claim Type:</b>	110		
<b>Service Number:</b>	4617		
<b>Damage Code:</b>	0020		
<b>Labor Operations:</b>	2 Wheels remove+reinstall	4405 2000	20 TU
	Brake pads, front remove+reinstall (Includes brake fluid inspection/addition and front brake calipers cleaning)	4636 2050	50 TU
	If applicable: 2 Front brake disc remove+reinstall (Includes front brake caliper loosening and fastening)	4650 2050	50 TU
<b>Diagnostic Time:</b>	Road test prior to service procedure	0121 0002	10 TU
	Road test after service procedure	0121 0004	10 TU
	Technical diagnosis at dealer's discretion (Refer to Section 2.2.1.2 and Audi Warranty Online for DADP allowance details)		
<b>Claim Comment:</b>	As per TSB #2040964/3		

All warranty claims submitted for payment must be in accordance with the *Audi Warranty Policies and Procedures Manual*. Claims are subject to review or audit by Audi Warranty.

# Technical Service Bulletin



## Required Parts and Tools

Part Number	Part Description	Quantity
4G0698151K	1 set of brake pads for disc brakes	1 set
4G0615301G or 4G0615301Q	Front brake discs (if applicable)	2

## Additional Information

All parts and service references provided in this TSB (2040964) are subject to change and/or removal. Always check with your Parts Department and service manuals for the latest information.