

TECHNICAL BULLETIN  
JTB00343NAS4  
09 SEP 2016



© Jaguar Land Rover North America, LLC

NOTE: The information in Technical Bulletins is intended for use by trained, professional Technicians with the knowledge, tools, and equipment required to do the job properly and safely. It informs these Technicians of conditions that may occur on some vehicles, or provides information that could assist in proper vehicle service. The procedures should not be performed by 'do-it-yourselfers'. If you are not a Retailer, do not assume that a condition described affects your vehicle. Contact an authorized Jaguar service facility to determine whether this bulletin applies to a specific vehicle.

**This reissue replaces all previous versions. Please destroy all previous versions.**

Changes are highlighted in gray

**SECTION: 501-14**

Compact Key Handset - Lower-Level Service Repair

**AFFECTED VEHICLE RANGE:**

**F-TYPE (X152)**

**Model Year:** 2014 Onwards  
**VIN:** K00003 Onwards  
**Assembly Plant:** Castle Bromwich

**XF (X250)**

**Model Year:** 2013-2015  
**VIN:** S48437-U88785  
**Assembly Plant:** Castle Bromwich

**XJ Range (X351)**

**Model Year:** 2013 Onwards  
**VIN:** V34340 Onwards  
**Assembly Plant:** Castle Bromwich

**MARKETS:**

NAS

**CONDITION SUMMARY:**

**Situation:** The face of the compact key handset may peel away from the handset main body or the handset case may be bulging.

**Cause:** This may be caused by the handset manufacturing process.



**NOTE:** Replace only the affected compact key handset; it is not necessary to replace both handsets. All customer handsets must match after the conclusion of the repair.

**Action:** Should the customer express this concern, follow the Service Instruction outlined below.

**PARTS:**

C2D39384	Compact key kit [gloss finish]	1
C2D39385	Compact key kit [matte finish]	1

**TOOLS:**

No Tools Required

**WARRANTY:**

**NOTE:** Repair procedures are under constant review, and therefore times are subject to change; those quoted here must be taken as guidance only. Always refer to TOPIx to obtain the latest repair time.

**NOTE:** DDW requires the use of causal part numbers. Labor only claims must show the causal part number with a quantity of zero.

DESCRIPTION	SRO	TIME (HOURS)	CONDITION CODE	CAUSAL PART
Casing - Handset/Compact key - Renew - One - F-TYPE	<b>86.52.44</b>	0.1	49	T2R10494
Casing - Handset/Compact key - Renew - One - XF, XJ	<b>86.52.44</b>	0.1	49	C2D18085

**NOTE:** Normal Warranty procedures apply.

### **SERVICE INSTRUCTION:**

**NOTE:** Replace only the affected compact key handset; it is not necessary to replace both handsets. All customer handsets must match at the conclusion of the repair.

1. Identify the type of compact key handset currently fitted [gloss finish or matte finish] to the vehicle to ensure a like-for-like replacement handset is fitted.

**NOTE:** Refer to SSM71619 [Compact key low level repair, animation of process] to view the animation file.

2. Remove the chrome cap; place to one side.

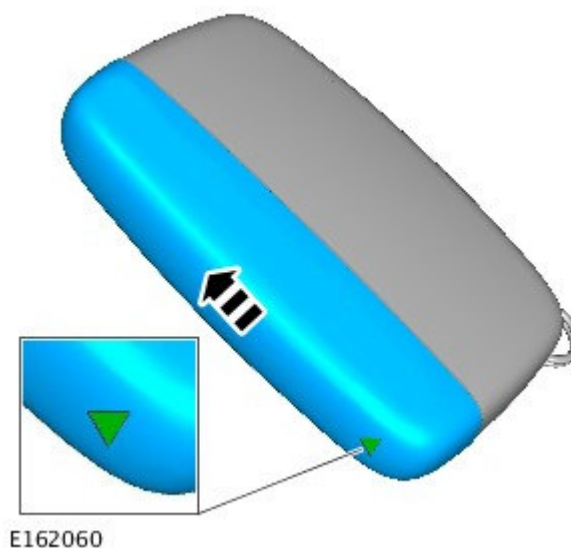

3. Remove the key blade.

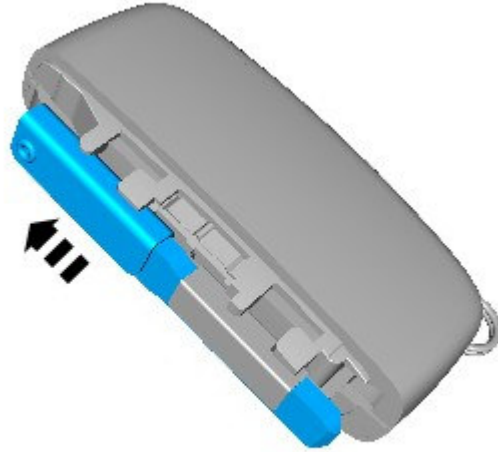

E162061

4. Using the key blade, remove and discard the lower case.

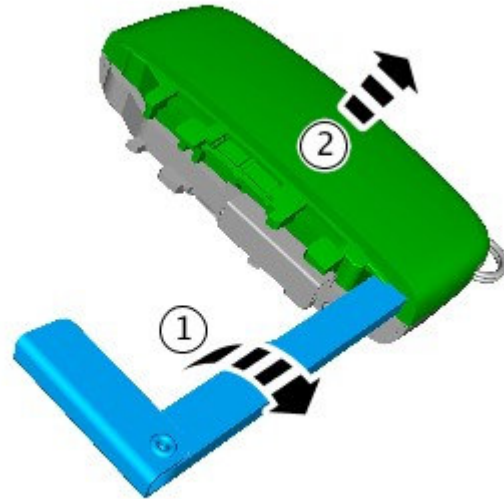

E162062

5. Remove the battery from the upper case.

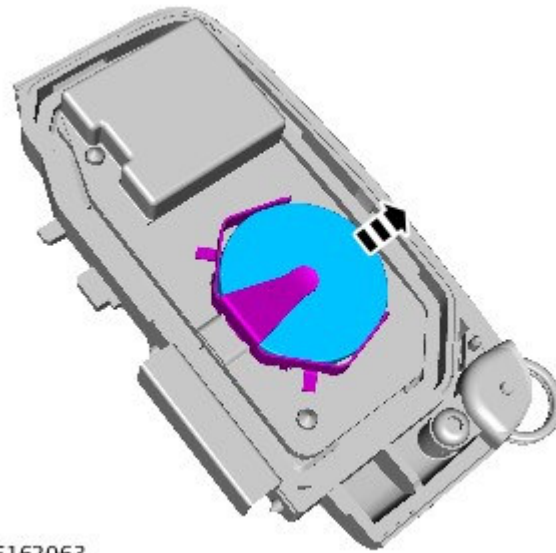

E162063

6. **⚠ CAUTION: Make sure the Printed Circuit Board [PCB] is not damaged when removing the black anti-tamper cover. If the copper coil antenna is damaged, the unit will be unserviceable.**

Using a suitable tool, cut the fixings of the black anti-tamper cover and lift away from the Printed Circuit Board [PCB].

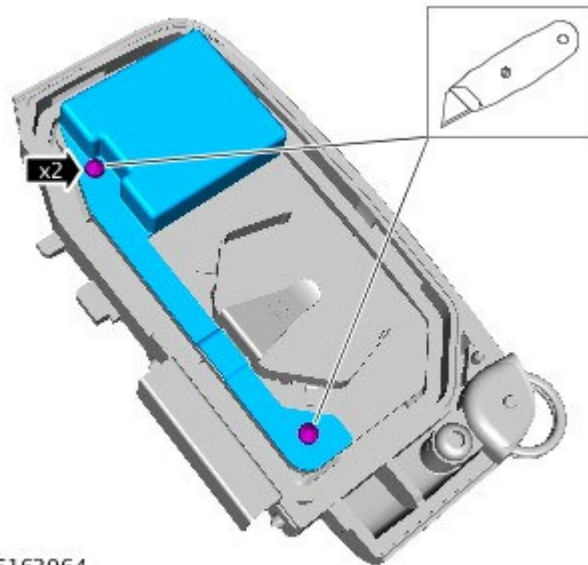

E162064

7. **⚠ CAUTION: When removing the PCB, only handle the outer edges of the board.**

Remove the PCB; place to one side.

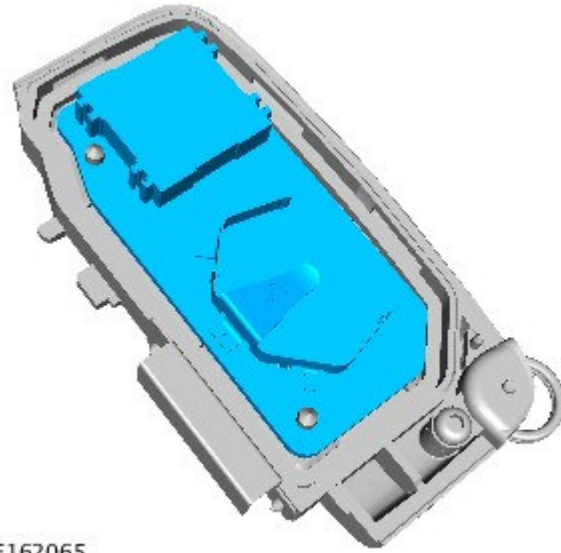

E162065

8. Remove the key ring retainer; place to one side.



E162066

9. Remove the silicone seal from the lower case; place to one side.

- Discard the upper case.
-



E162067

**10.** Make sure the foam pads are installed in the lower case as shown.

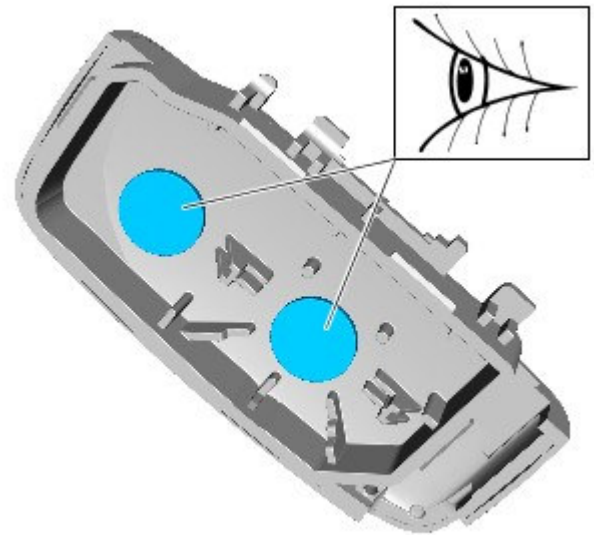

E162068

**11.** Install the silicone seal to the upper case.



E162067

**12.** Install the key ring retainer to the upper case:

- Tighten to 1Nm.

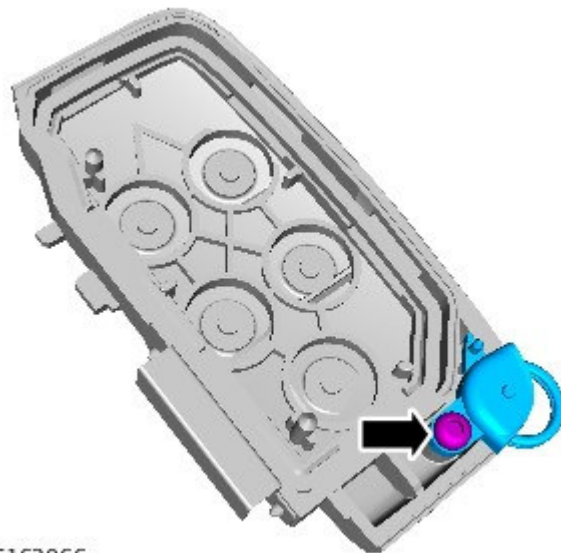

E162066

**13.** Make sure the key ring retaining pin is present in the upper case.



E162299

14.  **CAUTION:** When installing the PCB, only handle the outer edges of the board.

 **NOTE:** The PCB and cover are held in position with the foam pads on the new upper case.

Install the PCB to the upper case.



E162065

15. Install the PCB anti-tamper cover.



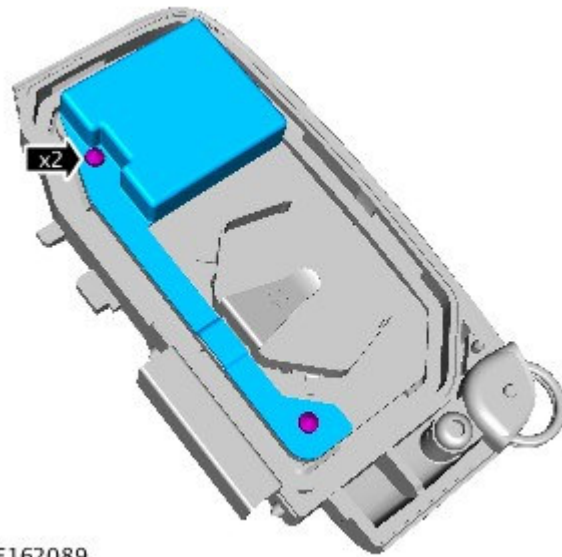

E162089

16.  **NOTE: Make sure the battery is installed positive [+] side up.**

Install the battery to the upper case.

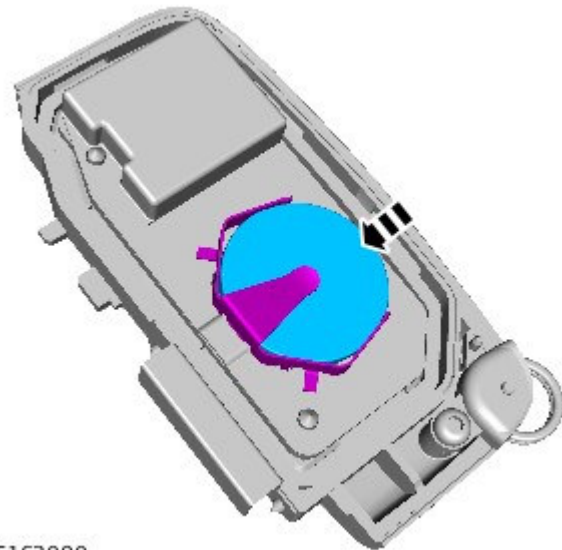

E162090

17. Install the lower case onto the handset.

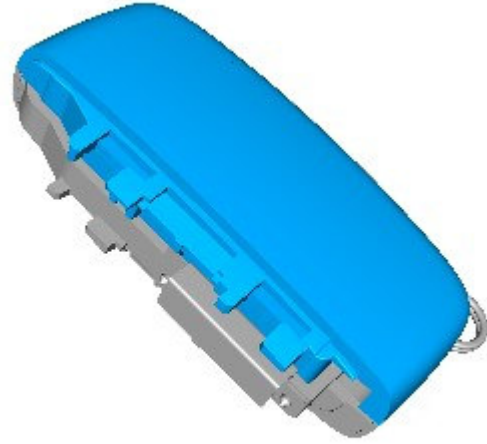

E162088

**18.** Install the key blade.

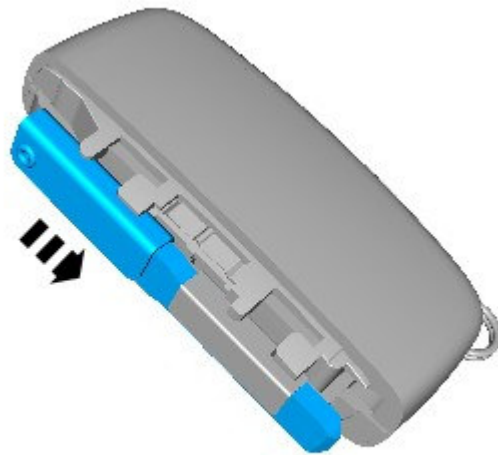

E162092

**19.** Install the chrome cap.

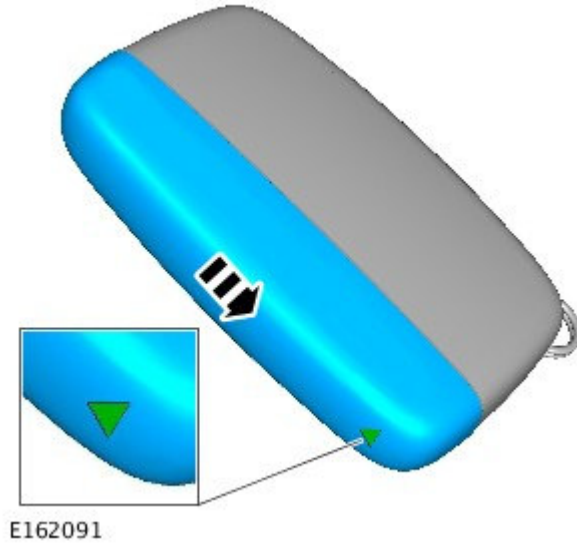

- 20.** Check the operation of the compact key handset [all functions].
- 21.** Perform steps 2-20 [if necessary] to additional compact key handsets.