

December 3, 2015

01179 Version 2

MIL Comes On with DTC P2422

Supersedes 15-010, dated February 1, 2015, to revise the information highlighted in **yellow**

REVISION SUMMARY

Under **WARRANTY CLAIM INFORMATION**, a template ID was added.

AFFECTED VEHICLES

Year	Model	Trim	VIN Range
2013–15	Accord (No Accord Hybrid or Accord Plug-in Hybrid)	ALL	ALL

SYMPTOM

The MIL is on with DTC P2422 (EVAP canister vent shut valve stuck closed malfunction).

POSSIBLE CAUSES

Dirt may be clogging the EVAP canister vent tube.

CORRECTIVE ACTION

Inspect the canister vent tube and, if necessary, replace the canister assembly and install a new canister vent tube kit.

PARTS INFORMATION

Part Name	Part Number	Quantity
Canister Drain Box Kit	06171-T2A-305	1
Canister Set (KA emission specification)	17011-T2A-A01	1
Canister Set (KL emission specification)	17011-T2A-L01	1
Retainer	17711-SNA-A01	1

WARRANTY CLAIM INFORMATION

The normal warranty applies.

Operation Number	Description	Flat Rate Time	Template ID	Failed Part Number
3101AL	Inspect and replace the canister assembly and install a new vent tube kit.	0.6 hr	15-010A	17011-T2A-A01

Defect Code: 05401

Symptom Code: 03203

Skill Level: Repair Technician

CUSTOMER INFORMATION: The information in this bulletin is intended for use only by skilled technicians who have the proper tools, equipment, and training to correctly and safely maintain your vehicle. These procedures should not be attempted by "do-it-yourselfers," and you should not assume this bulletin applies to your vehicle, or that your vehicle has the condition described. To determine whether this information applies, contact an authorized Honda automobile dealer.

INSPECTION PROCEDURE

Remove the bolt and the canister vent tube. Check if there is any dust or dirt in the tube by visually inspecting and tapping/shaking it.

- If the vent tube has any dust or dirt inside it, go to REPAIR PROCEDURE.
- If the vent tube has no dust or dirt present, this bulletin does not apply. Continue with normal troubleshooting.

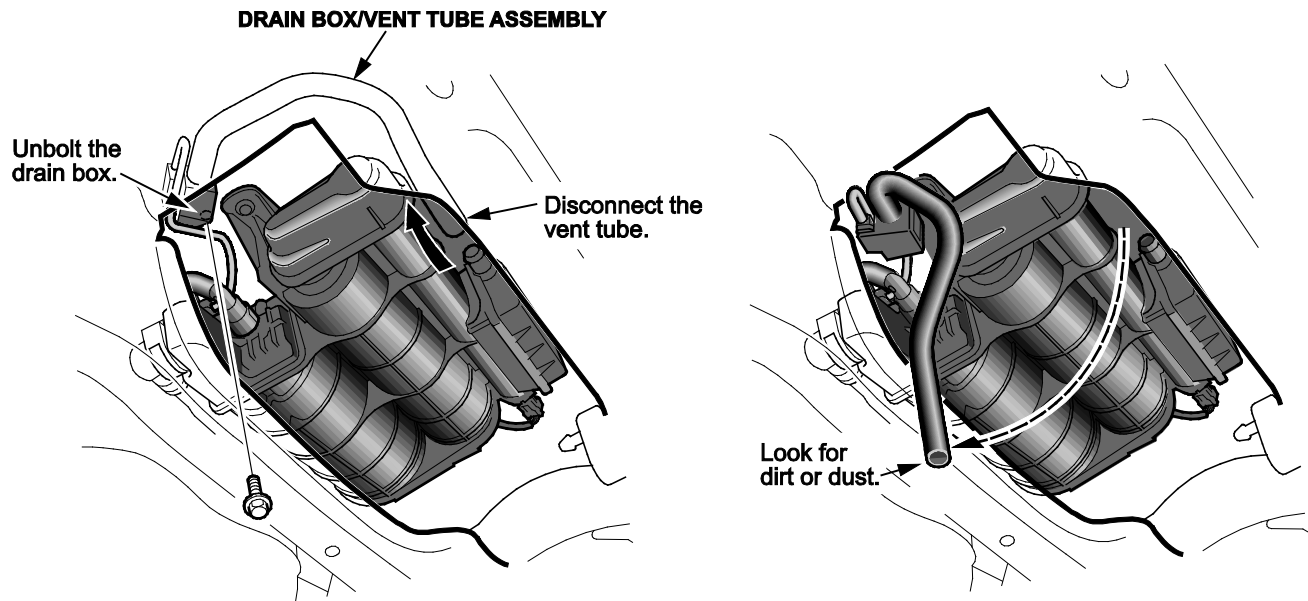

REPAIR PROCEDURE

1. Disconnect the purge lines, the EVAP canister vent shut valve connector, and the FTP sensor connector.

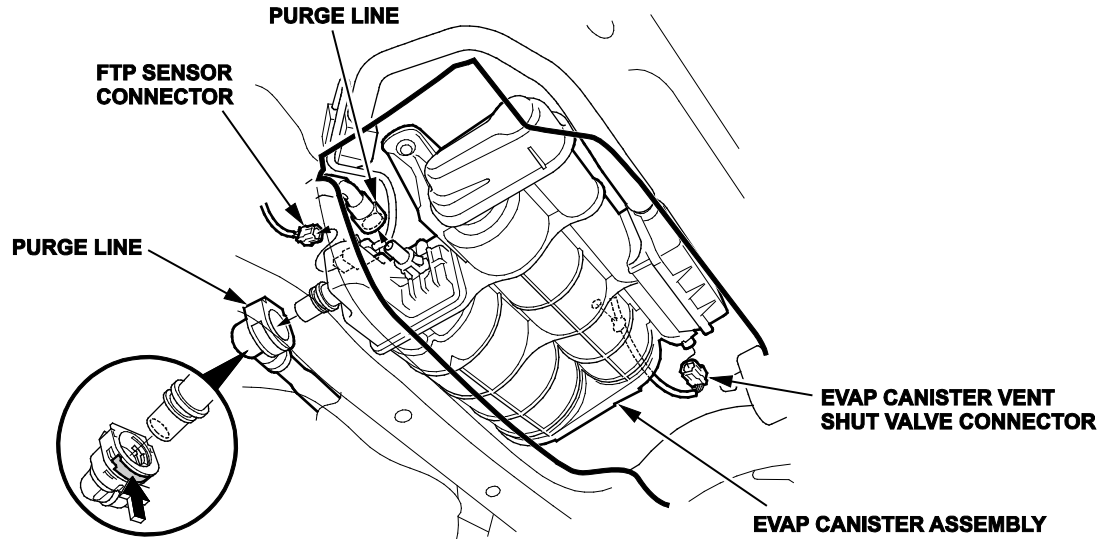

2. Remove the EVAP canister assembly by removing the three bolts.

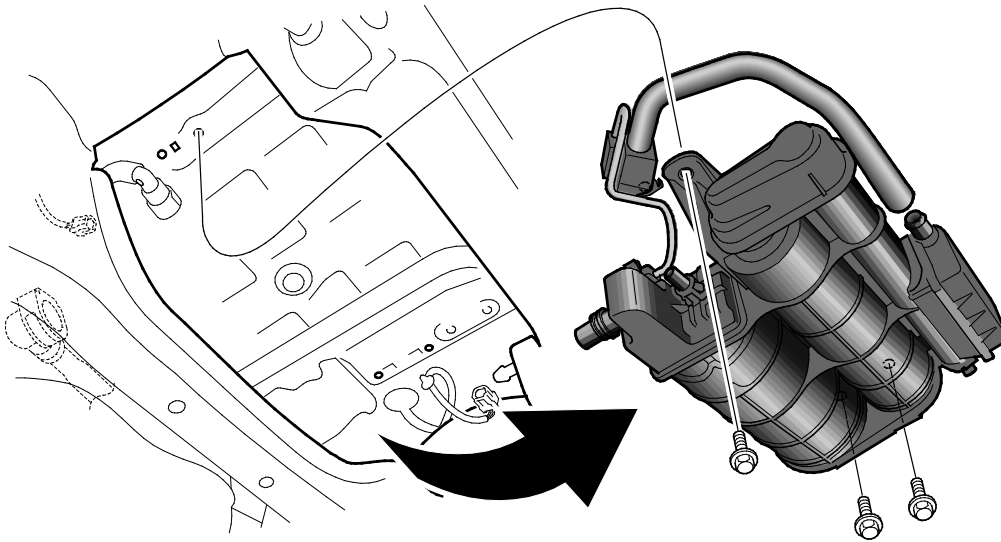

3. On the vehicle, install the protector onto the purge tube.
- Wrap the fuel purge protector so the slit faces the rear of the vehicle.

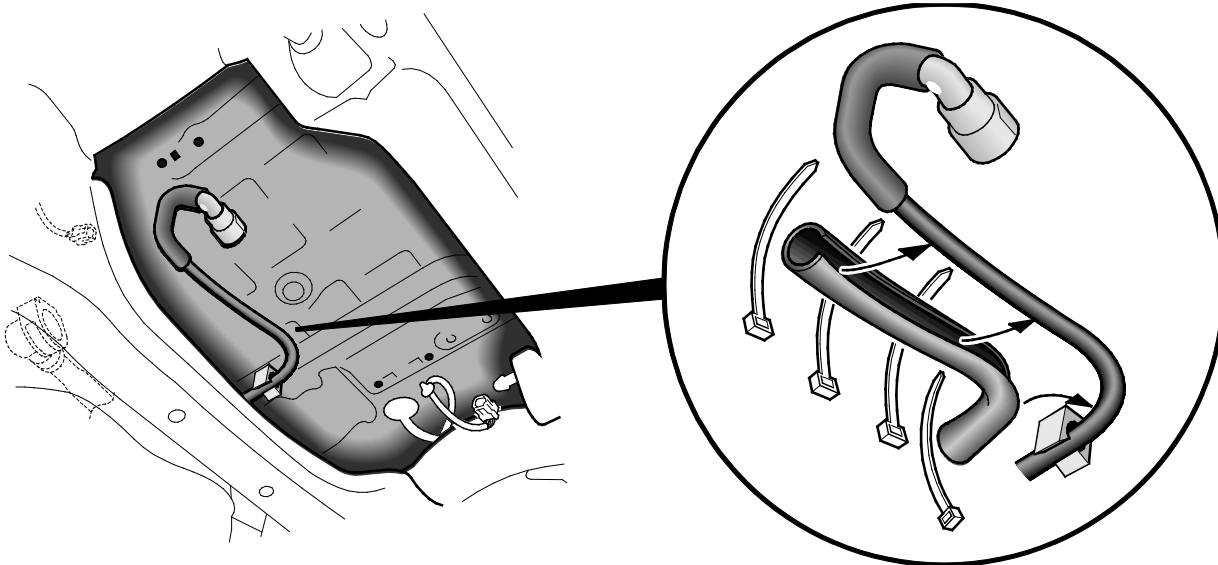

- Equally space the zip ties, and tighten the ties so that the locking tab is oriented on the top as shown.

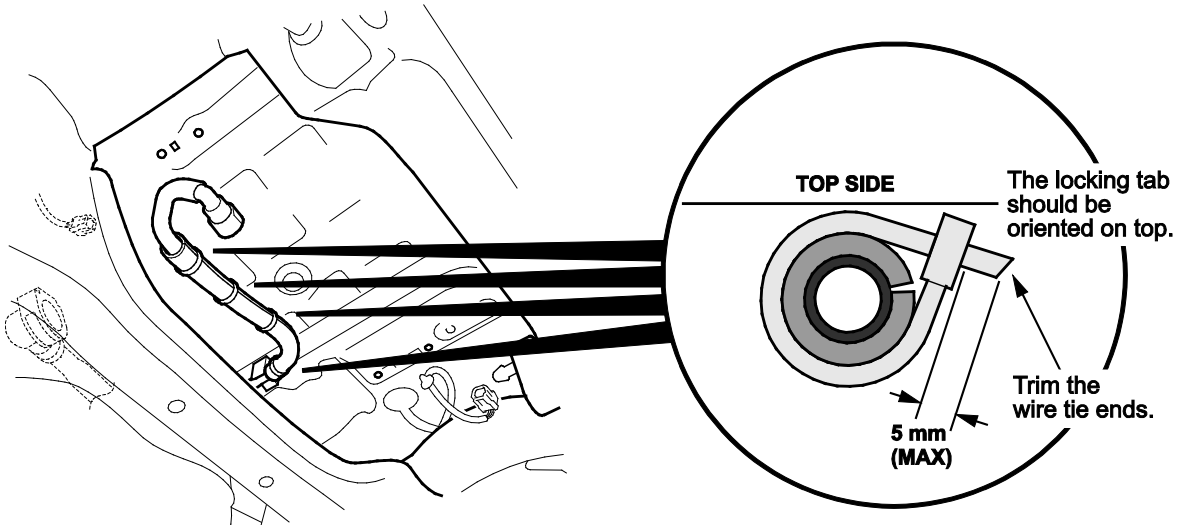

- Trim the ends of the zip ties to less than 5 mm.

4. Transfer the original canister vent shut valve and the vent pressure sensor to the new canister.

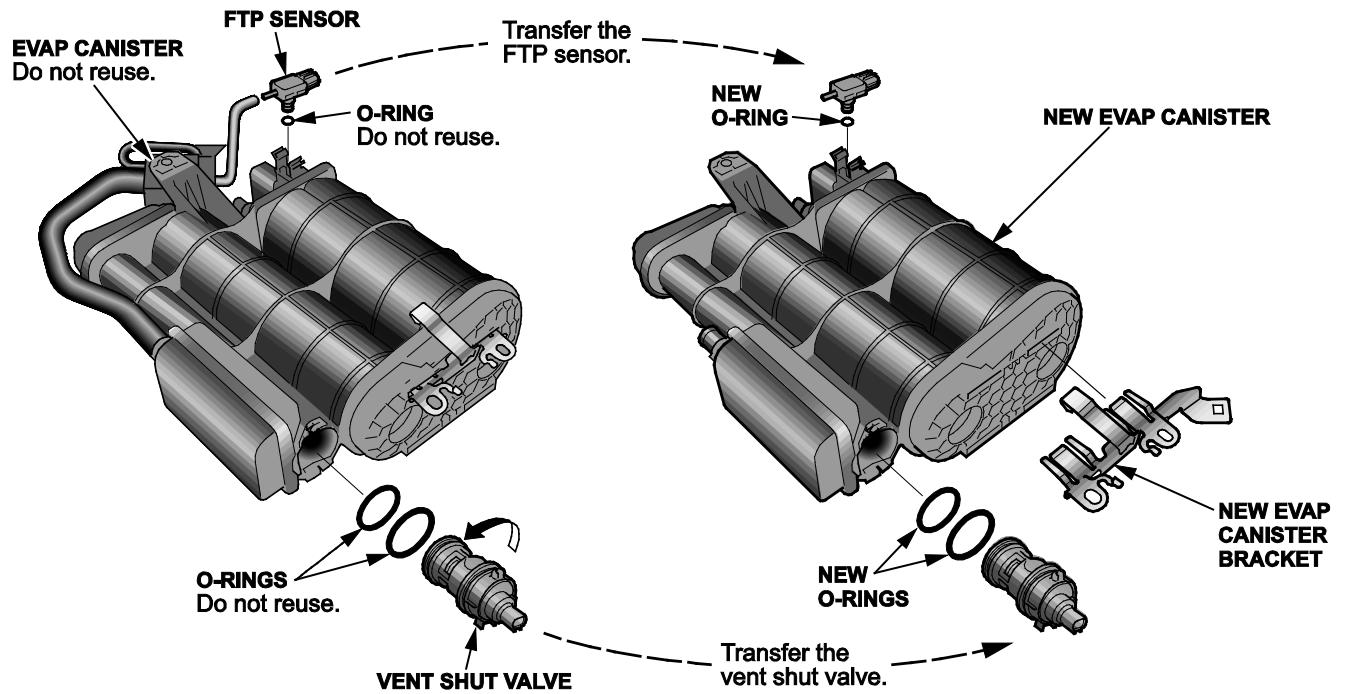

5. Install the new EVAP canister bracket.
6. Install the new canister drain box assembly and the new clip.

NOTE: Make sure the hoses are installed in the correct position by checking the alignment of the paint mark as shown.

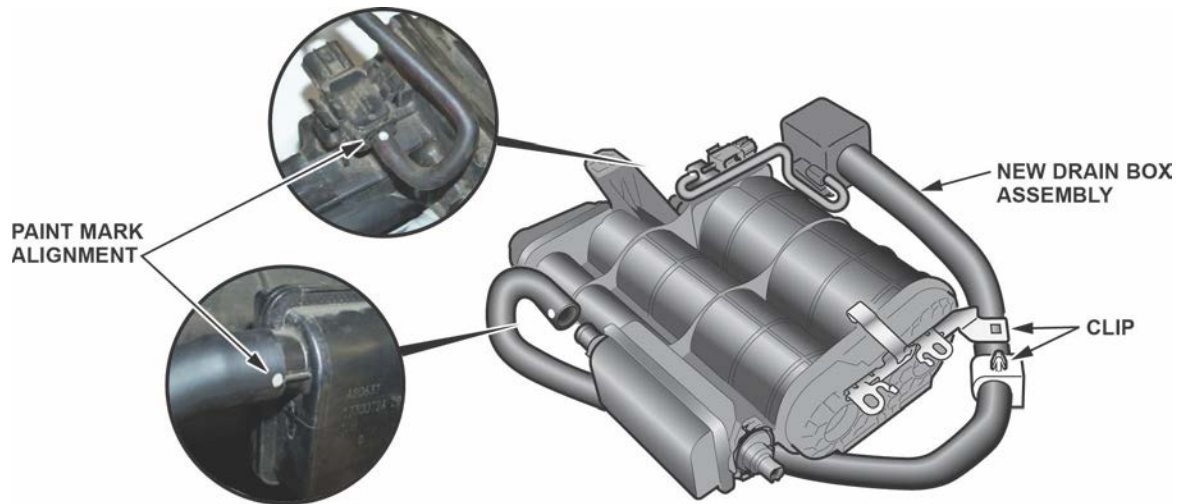

7. Install the new drain box bracket and new retainer as shown.

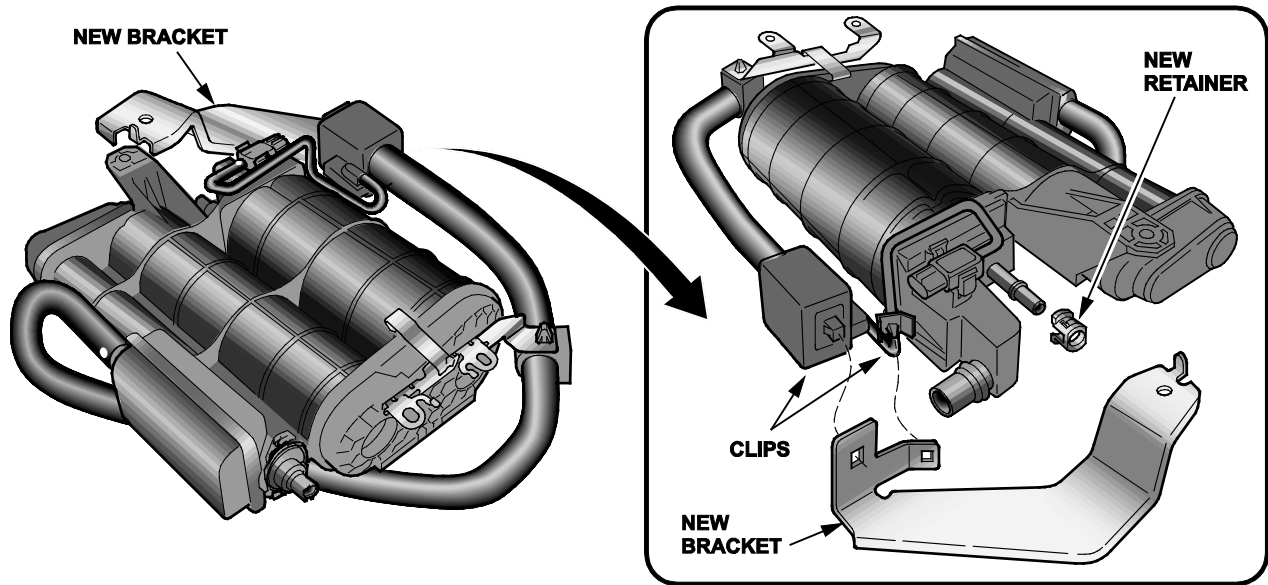

8. Reinstall the EVAP canister assembly and torque the bolts to **9.5 N·m (7 lb-ft)**.

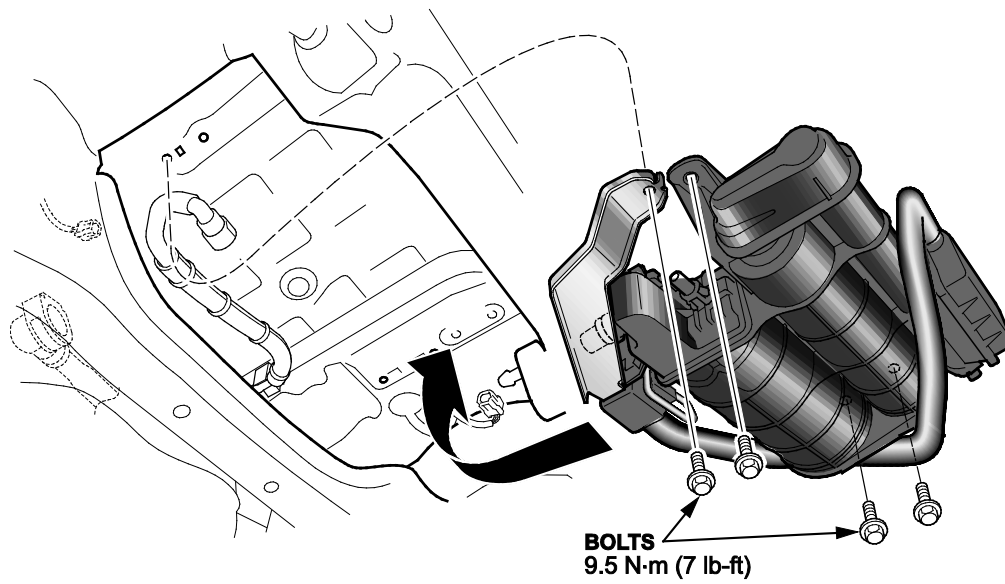

9. Connect the purge lines, the EVAP canister vent shut valve connector, and the FTP sensor connector.

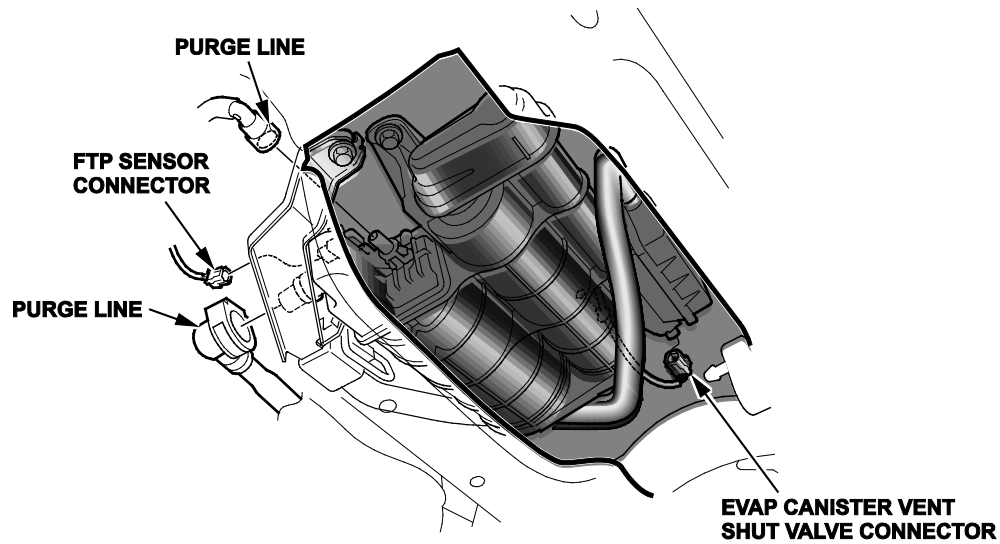

10. Using the HDS, clear the DTCs, then do the EVAP system function test.

- If the vehicle passes the EVAP system function test, the repair is complete.
- If the vehicle does not pass the EVAP system function test, there is still a problem. Continue with normal troubleshooting procedures.

END