

December 11, 2015

01465 Version 4

Safety Recall: SRS Unit

Supersedes S/B 15-013, dated October 31, 2015, to revise the information highlighted in **yellow**

AFFECTED VEHICLES

Year	Model	Trim	VIN Range
2003-04	Odyssey	ALL	Check the iN VIN status for eligibility

REVISION SUMMARY

- The INSPECTION PROCEDURE was changed.
- An add code was included under WARRANTY CLAIM INFORMATION.
- The SRS unit initialization procedure has changed. **Make sure your read these steps as they are different from previous versions.**

BACKGROUND

Electrical noise (interference) generated by the vehicle may inadvertently cause some or all of the vehicle's airbags to deploy. Many vehicles had an electrical noise suppressor installed under S/B 13-088, *Safety Recall: Electrical Noise May Cause Inadvertent Front Airbag Deployment*. In rare cases, even with the noise suppressor installed, some front airbags inadvertently deployed.

NOTE: If the VIN status inquiry indicates that the vehicle is subject to any open safety recalls, including an airbag inflator campaign/recall, make sure to also complete those recall repairs before returning the vehicle to the customer. If you are unable to complete any open recall, advise the customer of the recall status and when the recall may be completed.

CUSTOMER NOTIFICATION

Owners of affected vehicles will be sent a notification of this campaign.

Do an iN VIN status inquiry to make sure the vehicle is shown as eligible.

Some vehicles affected by this campaign may be in your used vehicle inventory. These vehicles must be repaired before they are sold.

Should your dealership sell an unrepaired vehicle that subsequently causes injury or damage because of the recalled item, the dealership will be solely responsible to the damaged party, and will be required to defend and indemnify American Honda for any resulting claims. To see if a vehicle in inventory is affected by this recall, do a VIN status inquiry before selling it.

CORRECTIVE ACTION

Inspect the vehicle and based on your results, do one of the following:

- Do nothing, the vehicle is up to date.
- Replace the SRS unit.
- Remove the noise suppressor and replace the SRS unit.

NOTE: When you install a new SRS unit, do not initialize the OPDS unit with the HDS. There is a new method to complete the SRS unit installation.

PARTS INFORMATION

Part Name	Part Number	Quantity
SRS Unit Kit (contains SRS Unit [1], Torx bolts [4], nylon tie [1], foam piece [1], clip [1])	06772-S0X-306	1

CUSTOMER INFORMATION: The information in this bulletin is intended for use only by skilled technicians who have the proper tools, equipment, and training to correctly and safely maintain your vehicle. These procedures should not be attempted by "do-it-yourselfers," and you should not assume this bulletin applies to your vehicle, or that your vehicle has the condition described. To determine whether this information applies, contact an authorized Honda automobile dealer.

WARRANTY CLAIM INFORMATION

NOTE: Do not use this warranty information for vehicles where the SRS unit is being replaced because of a collision.

Operation Number	Description	Flat Rate Time	Defect Code	Symptom Code	Template ID	Failed Part Number
7515A0	Inspect the SRS unit – the vehicle is OK.	0.3 hr	5YT00	JN600	15-013A	77960-S0X-L81
7511B7	Repair Procedure A - Inspect the vehicle, replace the SRS unit, and remove the noise suppressor. (includes resetting power window and idle learn)	1.0 hr	5YT00	JN600	15-013B	77960-S0X-L81
A	Add if you need to use the HDS to initialize the OPDS.	0.2 hr	5YT00	JN600	15-01B3	77960-S0X-L81
7511B8	Repair Procedure B - Inspect the vehicle and replace the SRS unit. (includes resetting power window and idle learn)	0.6 hr	5YT00	JN600	15-013C	77960-S0X-L81
A	Add if you need to use the HDS to initialize the OPDS.	0.2 hr	5YT00	JN600	15-01C3	77960-S0X-L81

Skill Level: Repair Technician

INSPECTION PROCEDURE

Make sure you follow the inspection steps 1-3 to make sure the SRS is functioning properly before doing a repair.

- Turn the ignition ON and check if the SRS indicator comes on for about 6 seconds, then goes out.
 - If the indicator comes on, then goes out after about 6 seconds, go to step 2.
 - If the indicator does not come on, or if it stays on, connect the HDS and write the DTCs on the RO.
 - Contact the customer and inform them that there is a problem with the SRS system and explain that replacing the SRS unit may not fix the problems causing the indicator light to illuminate as the SRS unit replacement was only intended to address the specific problem that led to the recall.
 - If the customer declines the customer pay repairs, make sure you write down the description of the problem and any DTCs on the RO. Also state that the SRS system is not operating properly and may pose a risk to the front occupants in the event of a collision; either because the airbags did not deploy, or the airbags deploy in a manner that does not account for all factors involved in the collision.
 - After the SRS unit is replaced, additional customer pay repairs will likely be needed to return the SRS system to proper operation.

2. Turn the ignition to OFF and wait for 30 seconds. Turn the ignition to ON and check if the SIDE AIRBAG OFF indicator comes on for about 6 seconds, then goes out.

NOTE: Do not confuse the SIDE AIRBAG OFF indicator and the PASSENGER AIRBAG OFF indicator.

- If the indicator comes on, then turns off after about 6 seconds, go to step 3.
 - If the indicator does not come on at all, or comes on and stays on, connect the HDS and write the DTCs on the RO.
 - Have the service advisor contact the customer and inform them that there is a problem with the side airbag and explain that replacing the SRS unit may not fix the problems causing the indicator to illuminate. The SRS unit replacement was only intended to address the specific problem that led to the recall.
 - If the customer declines the customer pay repairs, make sure you write down the description of the problem and any DTCs on the RO. Also, state that the SRS system is not operating properly and may pose a risk to the front occupants in the event of a collision; either because the airbags may not deploy, or the airbags may deploy in a manner that does not account for all factors involved in the collision.
 - After the SRS unit is replaced, additional customer pay repairs will likely be needed to return the SRS system to proper operation.
3. Make sure the OPDS is working properly by leaving the ignition turned to ON, then grabbing and holding the passenger seat back outside bolster with both hands for about 30 seconds. The SIDE AIRBAG OFF indicator should come on.
 - If the SIDE AIRBAG OFF indicator comes on, go to step 4.
 - If the indicator does not come on, connect the HDS and write any SRS DTCs on the RO.
 - Have the service advisor contact the customer and inform them that there is a problem with the OPDS and explain that replacing the SRS unit may not fix the problems. The SRS unit replacement was only intended to address the specific problem that led to the recall.
 - If the customer declines the customer pay repairs, make sure you write down the description of the problem and any DTCs on the RO. Also state that the SRS system is not operating properly and may pose a risk to the front occupants in the event of a collision; either because the airbags may not deploy, or the airbags may deploy in a manner that does not account for all factors involved in the collision.
 - After the SRS unit is replaced, additional customer pay repairs will likely be needed to return the SRS system to proper operation.
 4. Make sure you have the anti-theft codes for the audio and navigation system (if applicable) and write down the frequencies for the audio unit presets.
 5. Disconnect the negative battery cable and wait at least 3 minutes before beginning work.
 6. Remove the center lower trim.

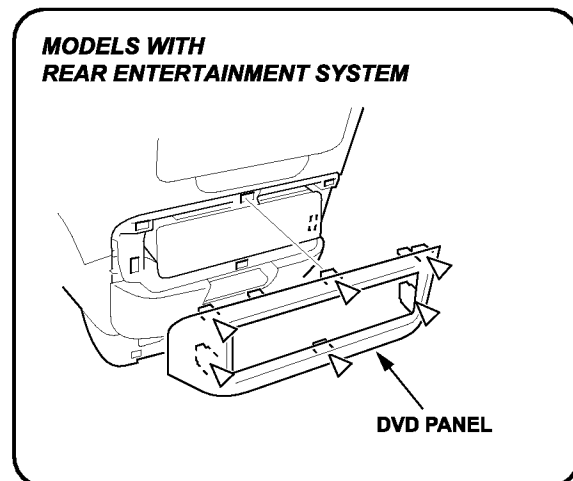
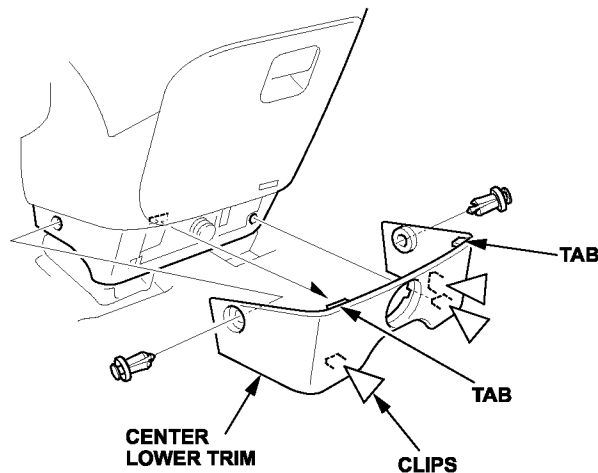

7. Remove the driver's and front passenger's lower heater covers.

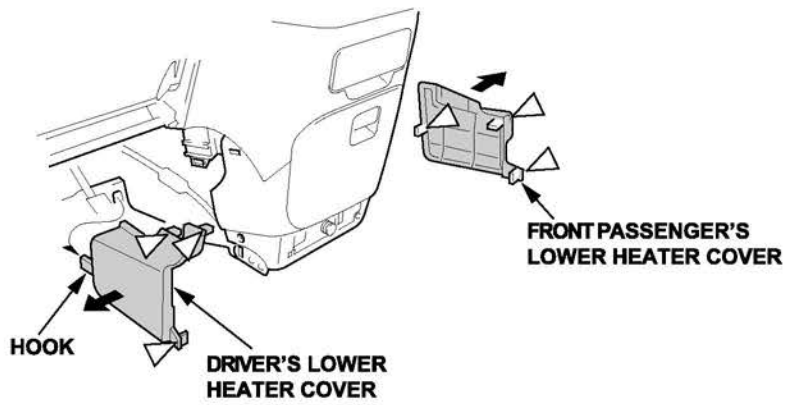

8. Inspect the subharness and note its arrangement:

- The original subharness is installed in the vehicle.
- There is an updated subharness connected to the noise suppressor.
- There is an updated subharness that has been taped up as shown and the noise suppressor has been removed.

UPDATED SRS SUBHARNESS WITH NOISE SUPPRESSOR

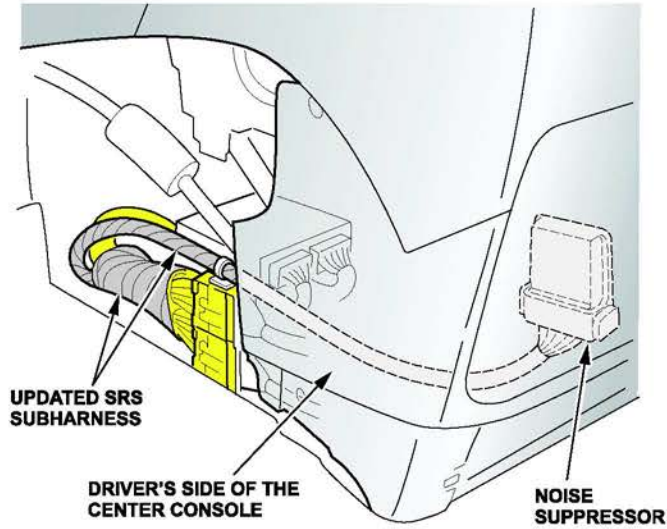

ORIGINAL SRS SUBHARNESS

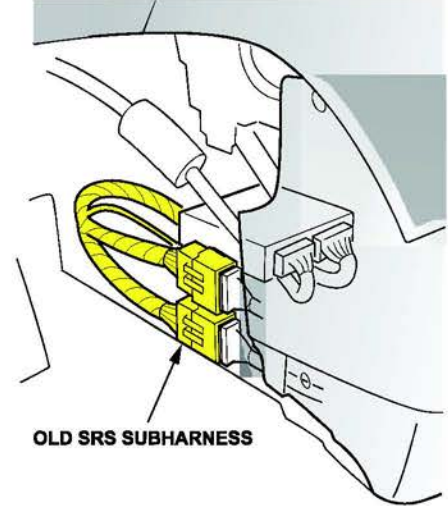

UPDATED SRS SUBHARNESS WITH NO NOISE SUPPRESSOR

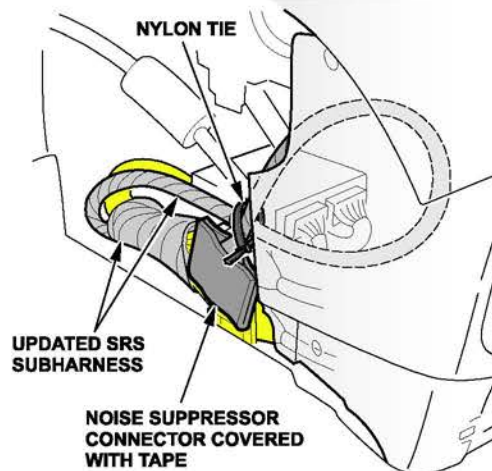

9. Write down the SRS unit P/N on the RO.

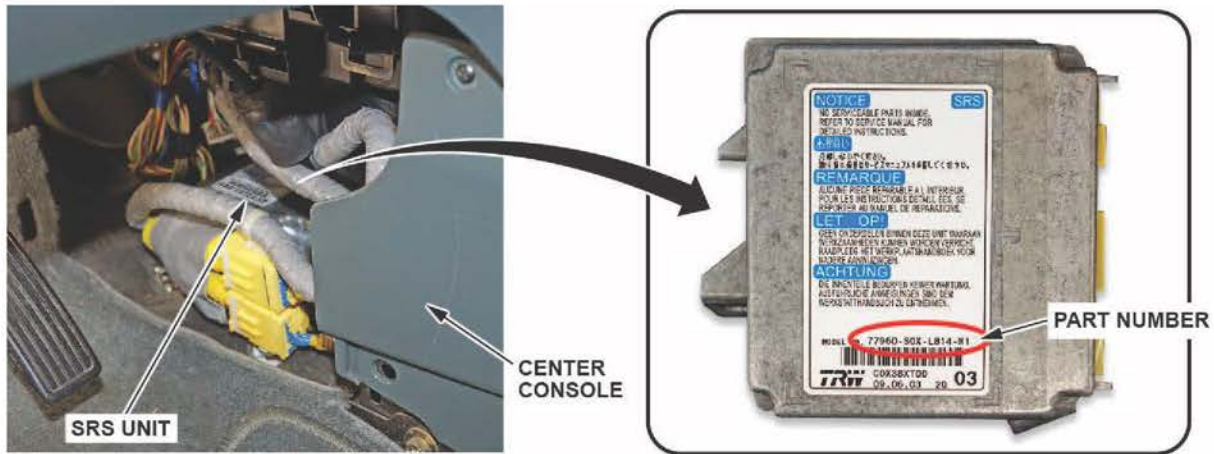

10. Check the SRS unit P/N and arrangement of the subharness against the table below and follow the correct repair action.

NOTE: When you install a new SRS unit, do not initialize the OPDS unit.

SRS Unit P/N	Subharness Arrangement	Repair Action
77960-S0X-L81X-XX	Original subharness is installed.	REPAIR PROCEDURE B
77960-S0X-L81X-XX	Updated subharness with a noise suppressor installed.	REPAIR PROCEDURE A
77960-S0X-407X	Original subharness is installed.	The vehicle is OK; no further action needed.
77960-S0X-407X	Updated subharness with a noise suppressor is installed.	REPAIR PROCEDURE A
77960-S0X-407X	Updated subharness with the connector taped up and the noise suppressor was removed.	The vehicle is OK; no further action needed.

REPAIR PROCEDURE A

1. Remove the center lower pocket.

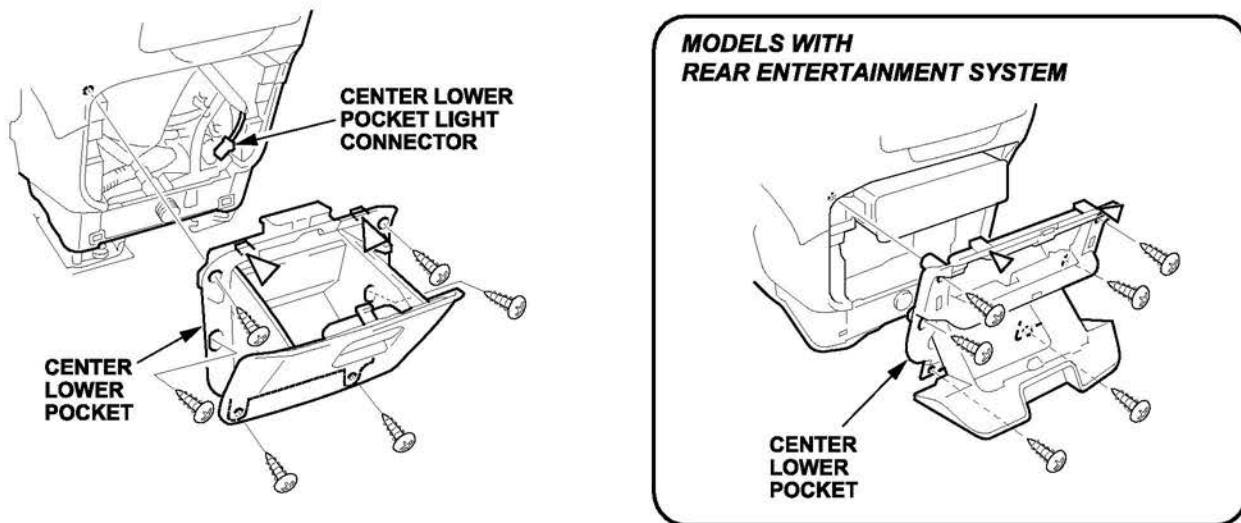

2. Remove the noise suppressor from the bracket and disconnect the connector. The suppressor will not be reused.

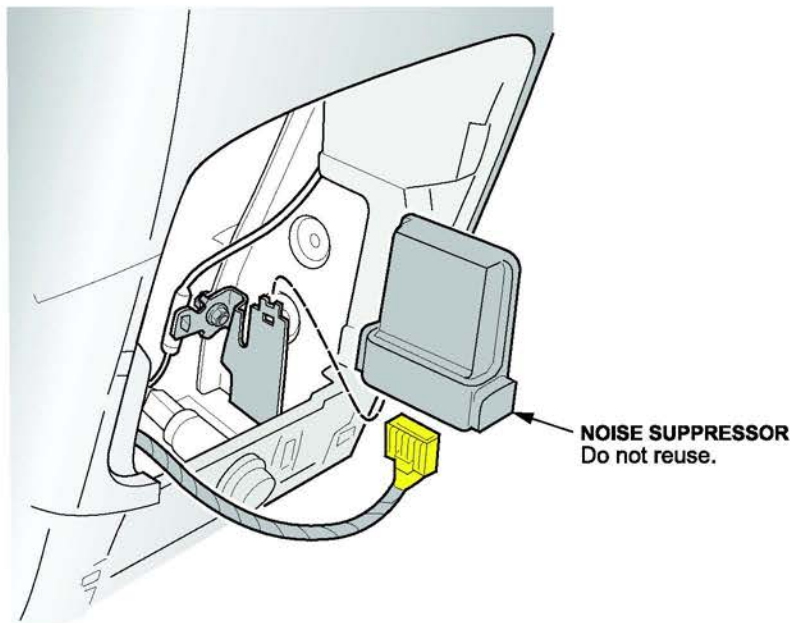

3. Disconnect the connector and the clip.

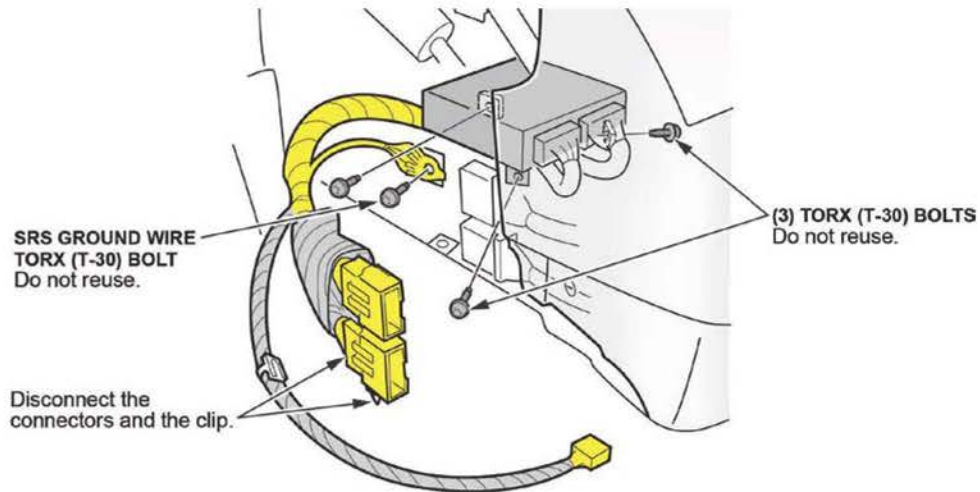

4. Remove the SRS unit by removing the three Torx bolts.
5. Remove the ground wire by removing the Torx bolt.
6. Remove the SRS unit and subharness from the vehicle.

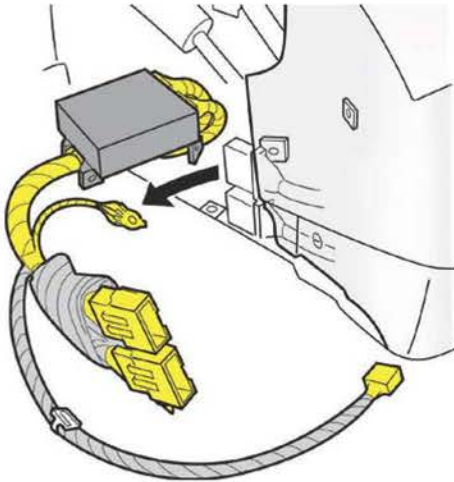

7. Remove the subharness clip from the underside of the SRS unit, then disconnect the connectors.

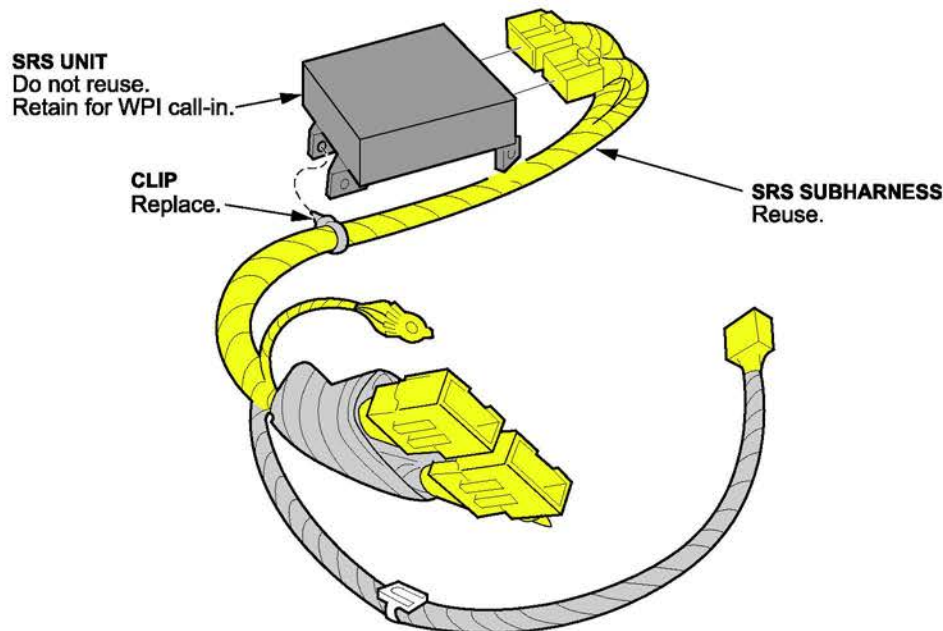

8. Replace the subharness clip.
9. Connect the subharness to the new SRS unit (P/N 77960-S0X-407) and connect the clip.

10. Apply a piece of 80 mm x 80 mm cushion tape over the noise suppressor connector as shown.

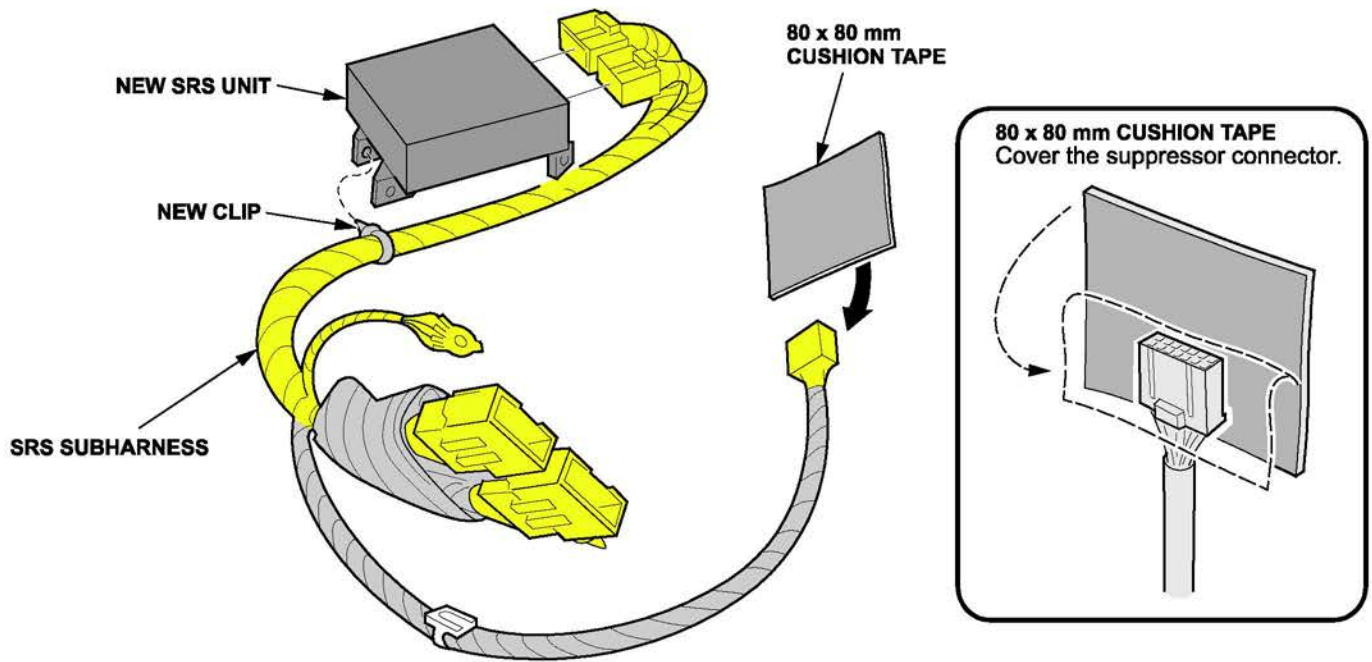

11. Reinstall the new SRS unit and existing SRS subharness into the vehicle with three new Torx bolts and torque them to **9.8 N·m (7.2 lb-ft)**.

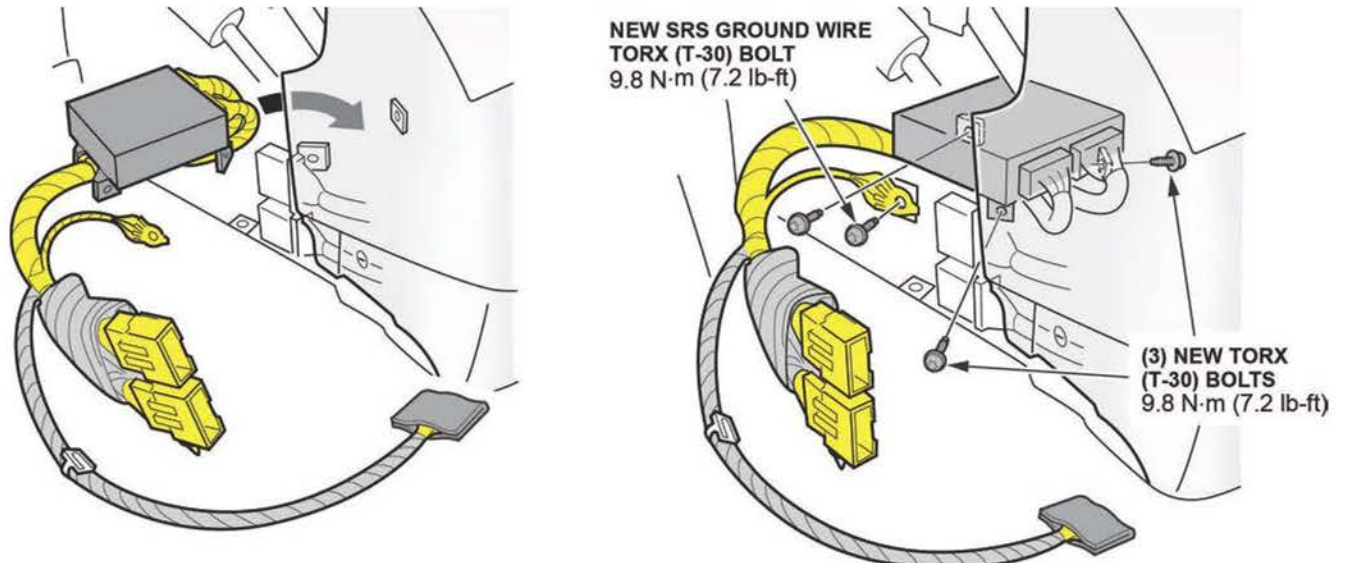

12. Reinstall the ground wire with a new Torx bolt and torque it to **9.8 N·m (7.2 lb-ft)**.

13. Reconnect the connectors and the clip.

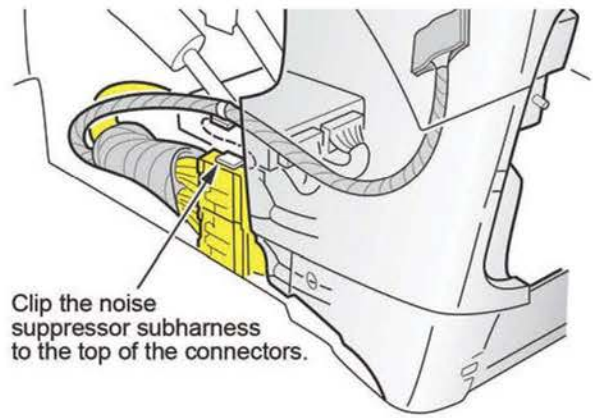
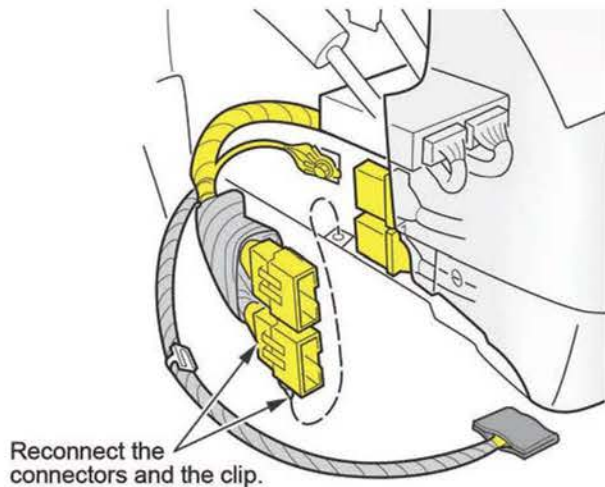

14. Clip the noise suppressor subharness to the top of the connectors.

15. Fold the subharness over and secure it with the wire tie as shown.

NOTE: Make sure the noise suppressor subharness does not block the driver's heater lower cover connection point.

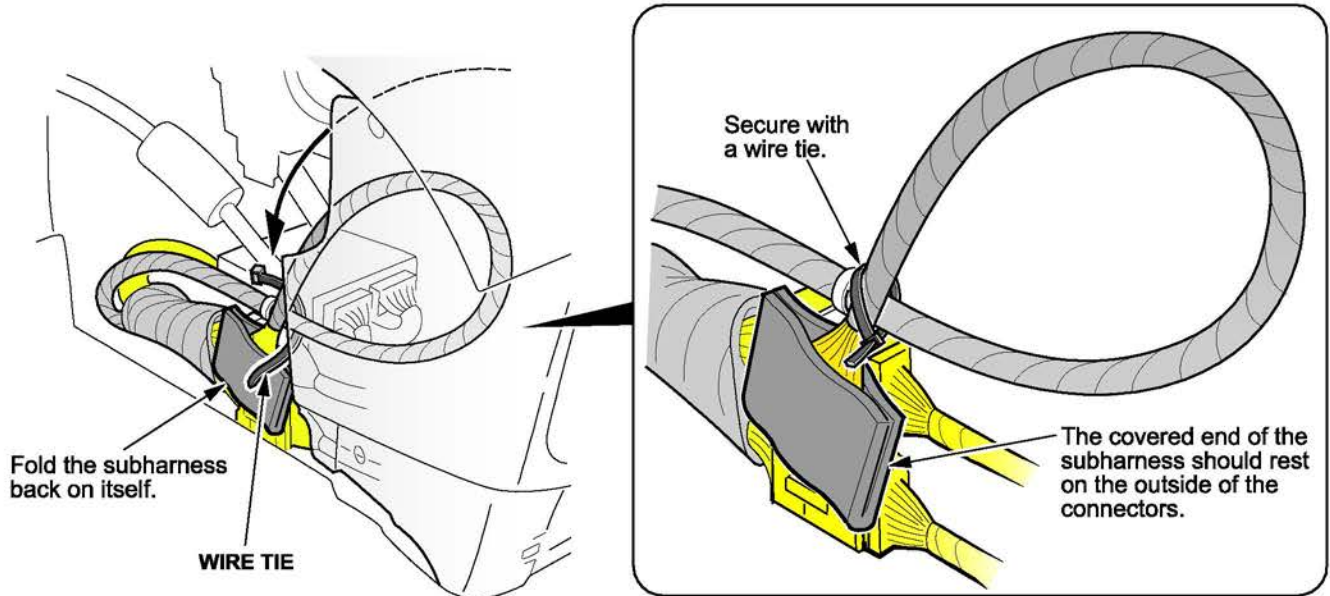

16. Reinstall the driver's and front passenger's lower heater covers, the center lower pocket, and the center console trim.

17. Reconnect the negative battery cable.

NOTE: Do not initialize the OPDS unit with the HDS.

18. To ready the vehicle for OPDS initialization, do this:

- Move the front passenger's seat back to the most upright position.
- Slide the front passenger's seat all the way back.
- Make sure there is nothing in the front passenger's seat back pocket.
- Make sure there is nothing under the front passenger's seat.
- Make sure the vehicle is parked out of direct sunlight.
- Make sure the vehicle's temperature has stabilized to the shop temperature (do not initialize the vehicle in extreme cold or hot temperatures).

19. To complete SRS unit initialization, **turn the ignition to ON for 1 full minute, turn the ignition off for another minute, then repeat two more times, making sure to wait 1 full minute between turning the ignition key ON or OFF.** After cycling the ignition 3 times, turn the ignition to ON and if the SRS indicator comes on for about 6 seconds then goes off, the SRS unit initialization is complete.

- If the OPDS is initialized (the indicator light is off) and it passed all the inspection items (INSPECTION PROCEDURE steps 1-3), go to step 20.
- If the SRS indicator remains on and the SIDE AIRBAG OFF indicator is flashing, the passenger seat back material around the OPDS may be causing an issue. Do the following for about 1 minute and then repeat step 18-19.
 - If the vehicle has a fabric seat cover, smooth out the fabric across the seat so that it doesn't bunch up or wrinkle.

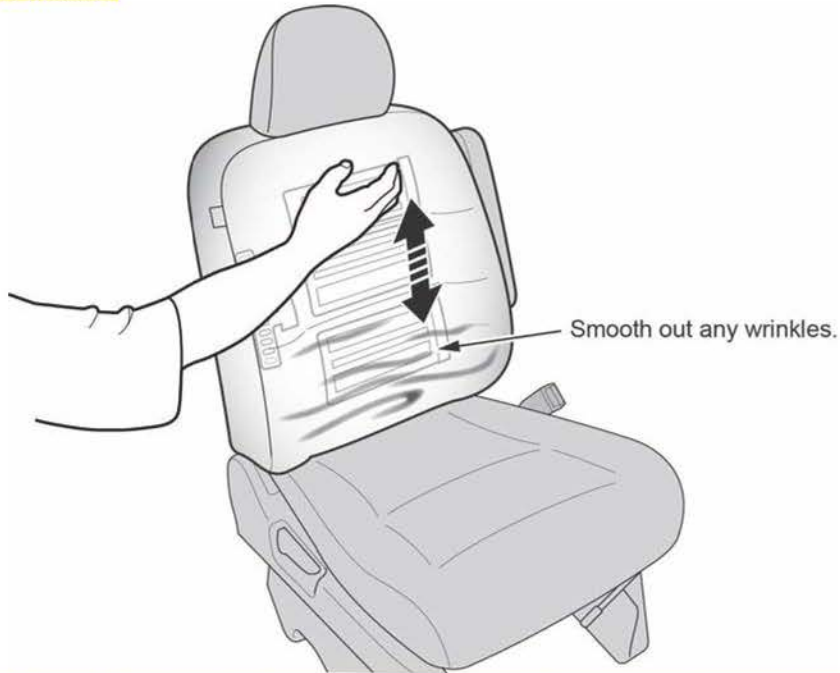

- If the vehicle has a leather seat, massage the leather to make sure there are no tight areas where the leather is stretched across the seat.

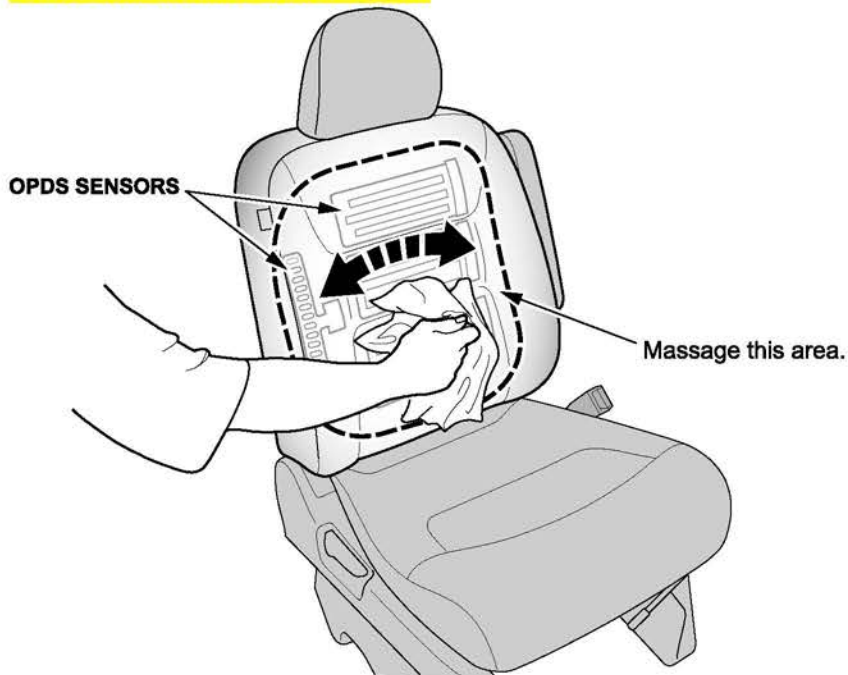

- If the SRS indicator remains on after the doing the OPDS initialization it is most likely because the interior of the front seat around the OPDS isn't completely dry. After drying the seat, repeat steps 18-19.
To dry the seat, do this:
 - Close the vehicle windows and sunroof.
 - Start the engine and run the HVAC at its lowest temperature setting and make sure the A/C is on.
 - Aim the vents at the OPDS sensor area.
 - If you can't safely run the vehicle to dry the seat, use a shop fan aimed directly at the OPDS sensor.
 - Try to initialize the OPDS every 30 minutes. If it doesn't initialize, continue drying the seat and try again in 30 minutes. Most seats will dry within 1.5 hours.
- If the SRS indicator remains on and the SIDE AIRBAG OFF indicator is flashing, use the HDS to initialize the OPDS from the SRS menu.
NOTE: If the SRS indicator is on and the SIDE AIRBAG OFF indicator is flashing, do not initialize the SWS (seat weight sensor).

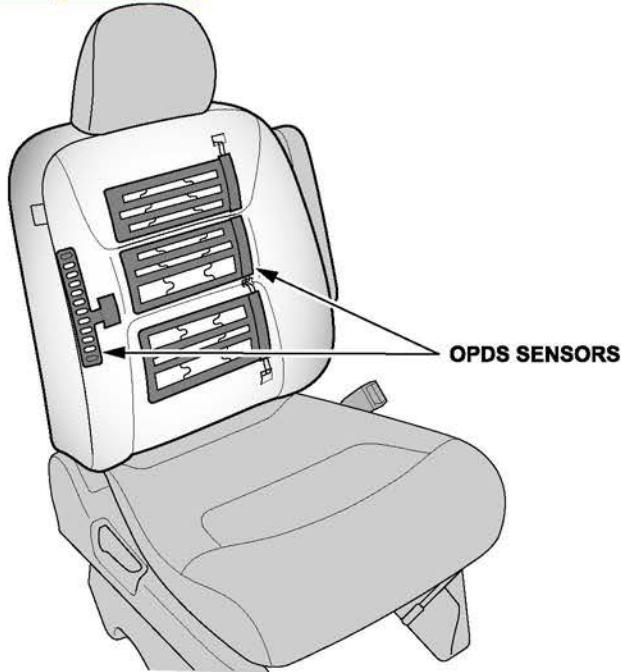

20. Enter the anti-theft codes for the audio and navigation system (if applicable), then enter the customer's audio unit presets.
21. Reset the power window control unit:
 - Turn the ignition to OFF, then back to ON.
 - Press the driver's window switch firmly to the second detent to lower the window all the way down.
 - When the window reaches the bottom, continue holding the driver's window switch in the down position for 2 seconds.
 - Pull the driver's window switch up and hold it to the second detent to raise the window without stopping.
 - When the window reaches the top, continue holding the driver's window switch in the up position for 2 seconds.
22. *Vehicles without navigation:* Set the clock.
23. Do the idle learn procedure.
 - Make sure all electrical items (A/C, audio unit, defogger, lights, etc.) are off.
 - Start the engine and let it warm up to its normal operating temperature (the cooling fans cycle twice).
 - Let the engine idle (throttle closed and all electrical items off) for 10 minutes.

REPAIR PROCEDURE B

NOTE: The foam piece and wire tie in the kit are not needed for this repair procedure.

1. Disconnect the two yellow connectors and remove the clip from the floor.

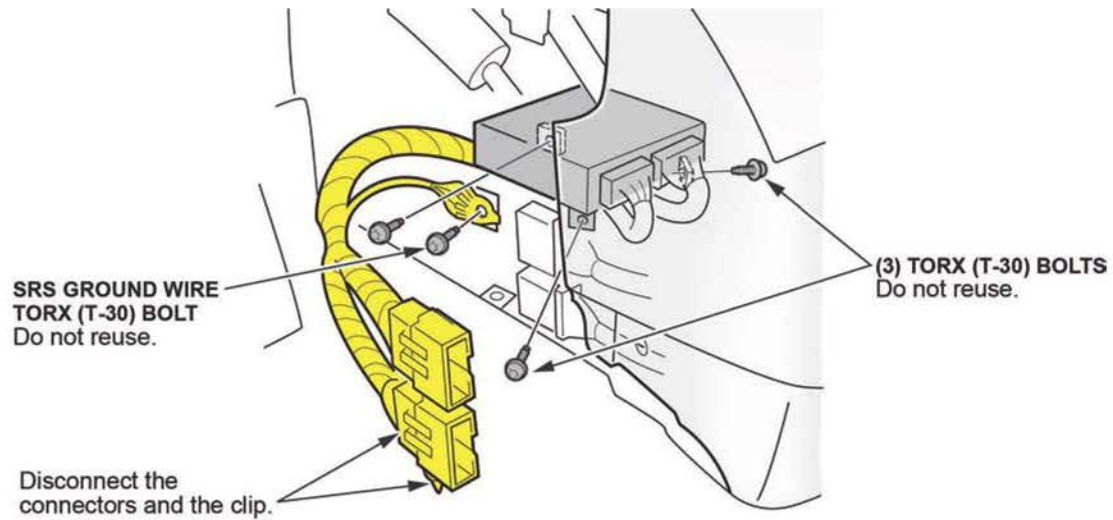

2. Remove the SRS unit by removing the three Torx bolts.
3. Remove the ground wire by removing the Torx bolt.
4. Remove the SRS unit and subharness from the vehicle.

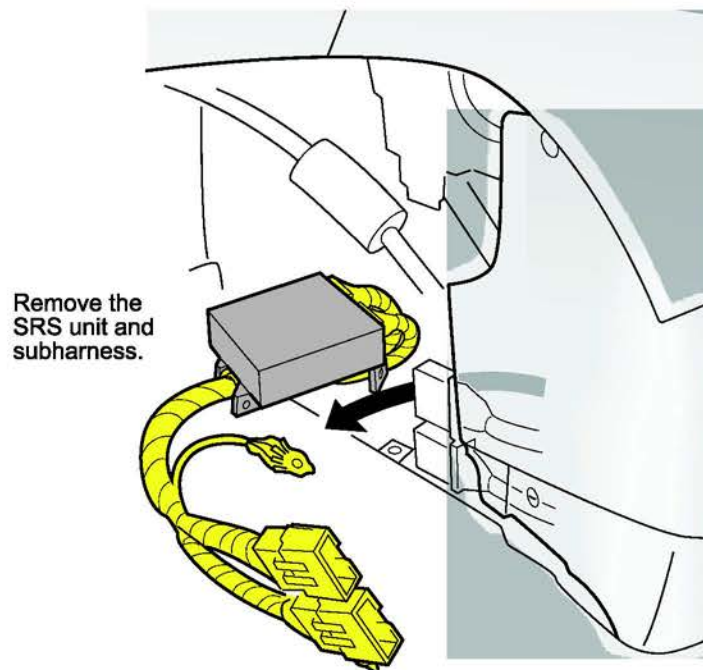

5. Remove the subharness clip from the underside of the SRS unit, then disconnect the subharness from the unit.

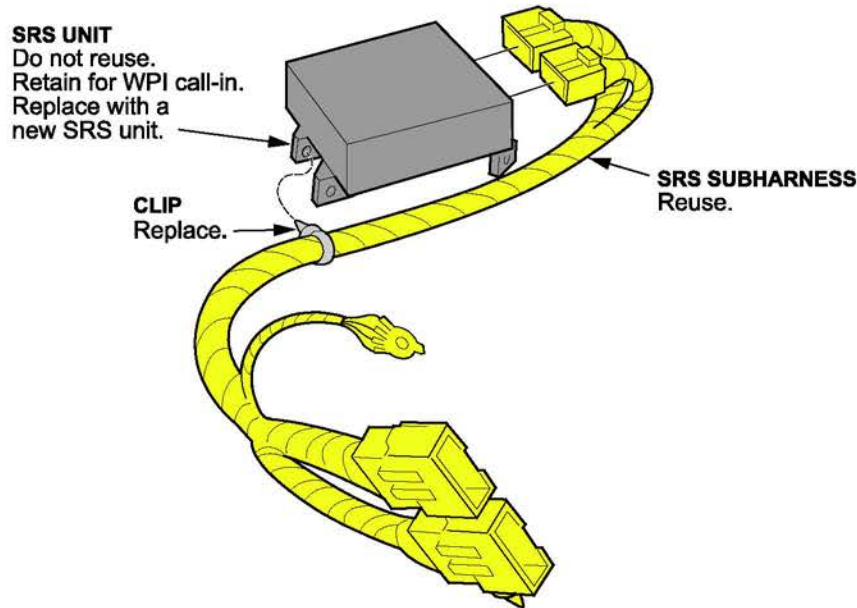

6. Install a new subharness clip onto the original subharness, then connect the subharness to the new SRS unit (P/N 77960-S0X-407).
7. Reinstall the new SRS unit and existing SRS subharness into the vehicle with three new Torx bolts and torque them to **9.8 N·m (7.2 lb-ft)**.

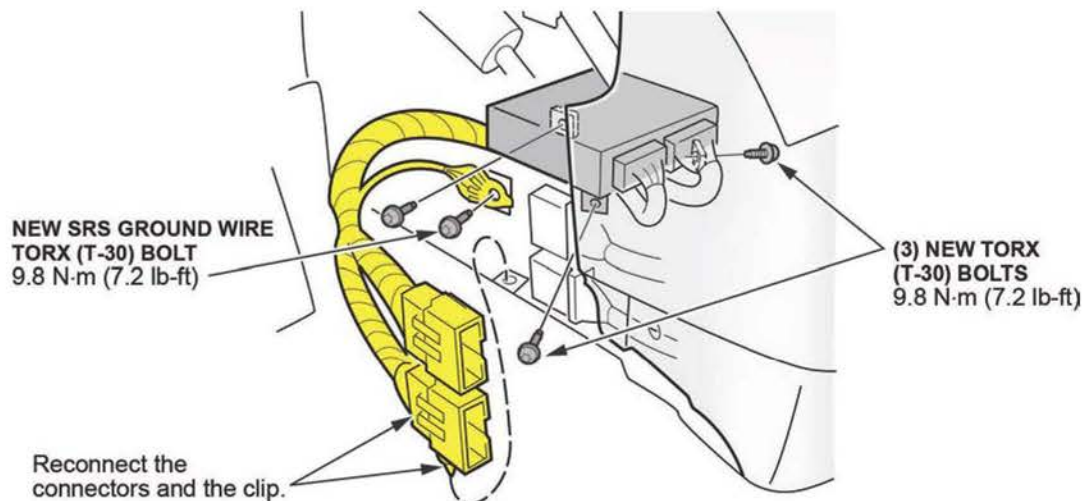

8. Reinstall the ground wire with a new Torx bolt and torque it to **9.8 N·m (7.2 lb-ft)**.
9. Reconnect the connectors and the clip.
10. Reinstall the driver's and front passenger's lower heater covers.
11. Reconnect the negative battery cable.

NOTE: Do not initialize the OPDS unit with the HDS.

12. To ready the vehicle for OPDS initialization, do this:

- Move the front passenger's seat back to the most upright position.
- Slide the front passenger's seat all the way back.
- Make sure there is nothing in the front passenger's seat back pocket.
- Make sure there is nothing under the front passenger's seat.
- Make sure the vehicle is parked out of direct sunlight.
- Make sure the vehicle's temperature has stabilized to the shop temperature (do not initialize the vehicle in extreme cold or hot temperatures).

13. To complete SRS unit initialization, **turn the ignition to ON for 1 full minute, turn the ignition off for another minute, then repeat two more times, making sure to wait 1 full minute between turning the ignition key ON or OFF.** After cycling the ignition 3 times, turn the ignition to ON and if the SRS indicator comes on for about 6 seconds then goes off, the SRS unit initialization is complete.

- If the OPDS is initialized (the indicator light is off) and it passed all the inspection items (INSPECTION PROCEDURE steps 1-3), go to step 14.
- If the SRS indicator remains on and the SIDE AIRBAG OFF indicator is flashing, the passenger seat back material around the OPDS may be causing an issue. Do the following for about 1 minute and then repeat step 18-19.
 - If the vehicle has a fabric seat cover, smooth out the fabric across the seat so that it doesn't bunch up or wrinkle.

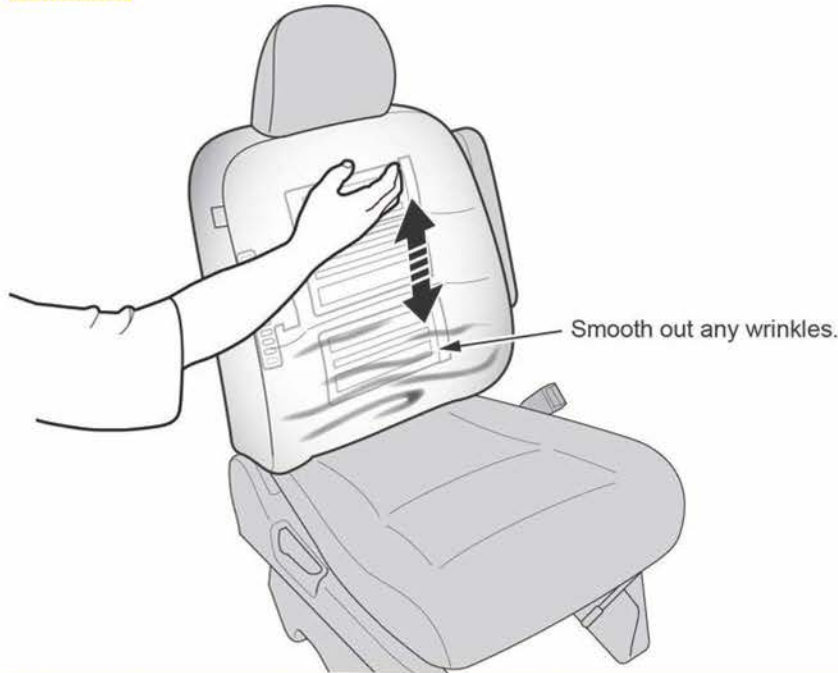

- If the vehicle has a leather seat, massage the leather to make sure there are no tight areas where the leather is stretched across the seat.

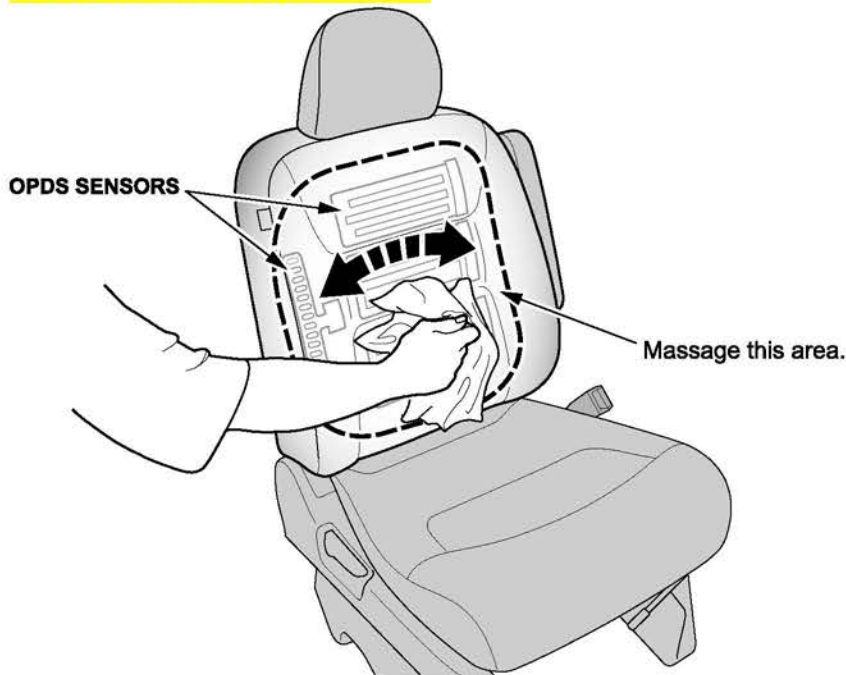

- If the SRS indicator remains on after the doing the OPDS initialization it is most likely because the interior of the front seat around the OPDS isn't completely dry. After drying the seat, repeat steps 12-13.
To dry the seat, do this:
 - Close the vehicle windows and sunroof.
 - Start the engine and run the HVAC at its lowest temperature setting and make sure the A/C is on.
 - Aim the vents at the OPDS sensor area.
 - If you can't safely run the vehicle to dry the seat, use a shop fan aimed directly at the OPDS sensor.
 - Try to initialize the OPDS every 30 minutes. If it doesn't initialize, continue drying the seat and try again in 30 minutes. Most seats will dry within 1.5 hours.
- If the SRS indicator remains on and the SIDE AIRBAG OFF indicator is flashing, use the HDS to initialize the OPDS from the SRS menu.
NOTE: If the SRS indicator is on and the SIDE AIRBAG OFF indicator is flashing, do not initialize the SWS (seat weight sensor).

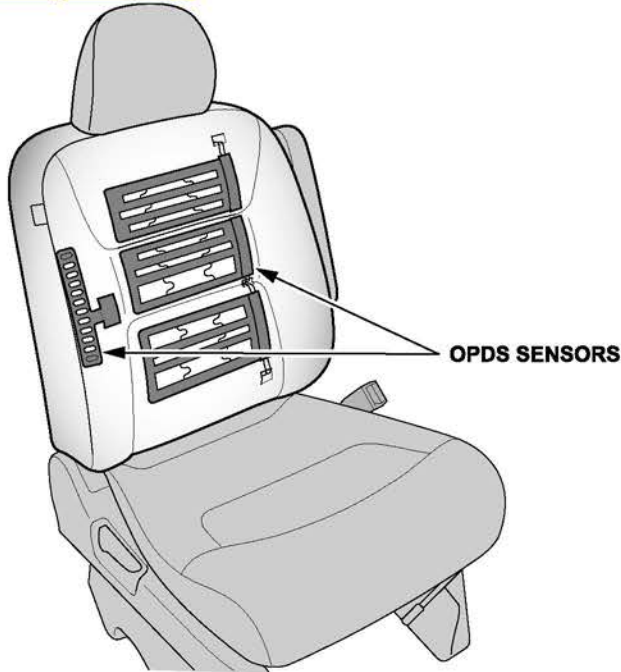

14. Enter the anti-theft codes for the audio and navigation system (if applicable), then enter the customer's audio presets.
15. Reset the power window control unit:
 - Turn the ignition to OFF, then back to ON.
 - Press the driver's window switch firmly to the second detent to lower the window all the way down.
 - When the window reaches the bottom, continue holding the driver's window switch in the down position for 2 seconds.
 - Pull the driver's window switch up and hold it to the second detent to raise the window without stopping.
 - When the window reaches the top, continue holding the driver's window switch in the up position for 2 seconds.
16. *Vehicles without navigation:* Set the clock.
17. Do the idle learn procedure.
 - Make sure all electrical items (A/C, audio unit, defogger, lights, etc.) are off.
 - Start the engine and let it warm up to its normal operating temperature (the cooling fans cycle twice).
 - Let the engine idle (throttle closed and all electrical items off) for 10 minutes.

END