



Surge, Hesitation, or Judder on Light Acceleration from a Stop (Supersedes 13-053, dated June 6, 2014, to revise the information marked with black bars.)

REVISION SUMMARY

Under PARTS INFORMATION, the lower valve body kit part numbers have changed.

SYMPTOM

A surge, hesitation, or judder may be felt as the vehicle accelerates from a stop. The symptoms are more noticeable before the vehicle is fully warmed up.

POSSIBLE CAUSE

The continuously variable transmission (CVT) needs hardware and software updates.

VEHICLES AFFECTED

2013 Accord L4 CVT (Japan-built) –
ALL VINs beginning with JHM

2013 Accord L4 CVT (US-built) –
ALL VINs beginning with 1HG

The following US-built vehicles:

2014 Accord 2-Door LX-S –
From VIN 1HGCT1B3.EA000001 thru
1HGCT1B3.EA012432

2014 Accord 2-Door EX –
From VIN 1HGCT1B7.EA000001 thru
1HGCT1B7.EA012545

2014 Accord 2-Door EX-L –
From VIN 1HGCT1B8.EA000001 thru
1HGCT1B8.EA012492

2014 Accord 4-Door LX –
From VIN 1HGCR2F3.EA000001 thru
1HGCR2F3.EA213610

2014 Accord 4-Door Sport –
From VIN 1HGCR2F5.EA000001 thru
1HGCR2F5.EA211625

2014 Accord 4-Door EX –
From VIN 1HGCR2F7.EA000001 thru
1HGCR2F7.EA211387

2014 Accord 4-Door EX-L –
From VIN 1HGCR2F8.EA000001 thru
1HGCR2F8.EA211218

CORRECTIVE ACTION

Install the updated transmission valve body kit, and update the PGM-FI software.

NOTE: You do not need to drop the subframe to complete this bulletin.

PARTS INFORMATION

Lower Valve Body Kit: P/N 06270-5C4-335

One kit contains the following parts:

Description	Qty.	P/N (for reference only)
Instruction Sheet	1	
Lower Valve Body	1	27000-RU2-070
Transmission Pan Gasket		21814-RJ2-003
10 MM Gasket	1	90471-PW7-A00
O-Rings		
21.8 X 1.9 MM	1	91301-RCT-004
14.8 X 1.8 MM	4	91308-RCA-A01
8.8 X 1.9 MM	2	91308-REJ-W01
7.7 X 1.9 MM	8	91311-PA9-004
11 X 1.9 MM	2	91314-PW4-003

Check Bolt Sealing Washer: P/N 90441-PK4-000

Drain Sealing Washer: P/N 90471-PX4-000

REQUIRED MATERIALS

Honda Genuine HCF-2 CVT Fluid: P/N 08200-HCF2
(Each vehicle requires up to 7 quarts.)

TOOL INFORMATION

1/4" drive 10 mm swivel socket; commercially available
(Snap-On TMUM10A or equivalent)



SOFTWARE INFORMATION

NOTE: Unnecessary or incorrect repairs resulting from a failure to update the HDS or MVCI are not covered under warranty.

MVCI Control Module (CM) Update:

Application Version 3.01.50 **or later**

Database Update 13-OCT-2015 **or later**

HDS Software Version: 3.017.012 **or later**

Before beginning the repair, make sure that both the HDS and the MVCI are updated as listed above.

Do only the update listed in this service bulletin.

Check that the MVCI indicates the applicable program ID listed below (or a later program ID) as the **Recommended Update** when the update begins.

If the MVCI displays **This vehicle does not need an update at this time** during the update, the software for this service bulletin is already installed.

For more information about updating the HDS, the MVCI, and vehicle systems, refer to Service Bulletin 01-023, *Updating Control Units/Modules*.

Year/Model/Trim	Program ID (or later)	Program P/N (or later)
2013 Accord 2-door LX-S (KA)	A23170	37805-5A2-317
2013 Accord 2-door LX-S (KL)	A33170	37805-5A3-317
2013 Accord 2-door EX, EX-L, EX-L Navi (KA)	A23180	37805-5A2-318
2013 Accord 2-door EX, EX-L, EX-L Navi (KL)	A33180	37805-5A3-318
2013 Accord 4-door LX (KA)	A23150	37805-5A2-315
2013 Accord 4-door LX (KL)	A33150	37805-5A3-315
2013 Accord 4-door Sport (KA)	A23170	37805-5A2-317
2013 Accord 4-door Sport (KL)	A33170	37805-5A3-317
2013 Accord 4-door EX, EX-L, EX-L Navi (KA)	A23160	37805-5A2-316
2013 Accord 4-door EX, EX-L, EX-L Navi (KL)	A33160	37805-5A3-316
2014 Accord 2-door LX-S (KA)	A2B720	37805-5A2-B72
2014 Accord 2-door LX-S (KL)	A3L320	37805-5A3-L32
2014 Accord 2-door EX, EX-L, EX-L Navi (KA)	A2B820	37805-5A2-B82
2014 Accord 2-door EX, EX-L, EX-L Navi (KL)	A3L420	37805-5A3-L42

Year/Model/Trim	Program ID (or later)	Program P/N (or later)
2014 Accord 4-door LX (KA)	A2B520	37805-5A2-B52
2014 Accord 4-door LX (KL)	A3L120	37805-5A3-L12
2014 Accord 4-door Sport (KA)	A2B720	37805-5A2-B72
2014 Accord 4-door Sport (KL)	A3L320	37805-5A3-L32
2014 Accord 4-door EX, EX-L, EX-L Navi (KA)	A2B620	37805-5A2-B62
2014 Accord 4-door EX, EX-L, EX-L Navi (KL)	A3L220	37805-5A3-L22

WARRANTY CLAIM INFORMATION

The normal warranty applies.

OP#	Description	FRT
2321P3	Replace valve body.	1.0
2321P3A	Update PGM-FI software.	0.2

Failed Part: 27000-RJ2-030

Defect Code: 03214

Symptom Code: 03217

Skill Level: Repair Technician

REPAIR PROCEDURE

Lower Valve Body Removal

NOTE: You do not need to drop the subframe to complete this bulletin.

1. Raise the vehicle on a lift.
2. Remove the engine under cover.

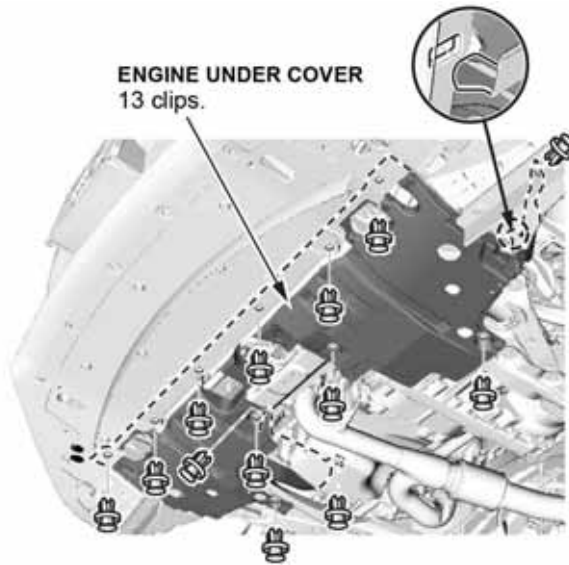

3. Remove the transmission drain plug, and drain the CVT fluid.

NOTE: Clean and remove any metal particles from the magnetic drain plug.

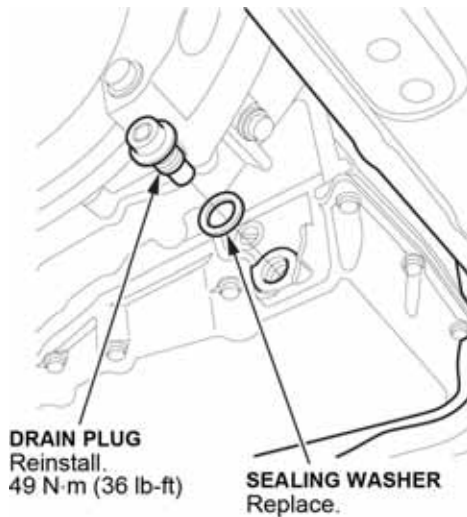

4. Reinstall the drain plug with a new sealing washer.

5. Remove the transmission fluid pan, then remove the dowel pins. Remove the transmission fluid pan gasket; it will not be reused.

NOTE: One fluid pan bolt is partially obstructed by the subframe; remove it using a 1/4" drive 10 mm swivel socket.

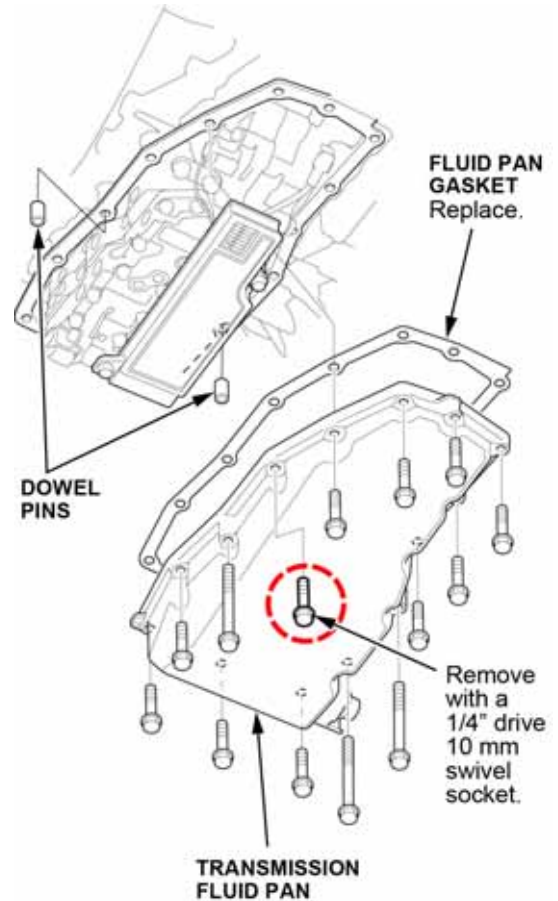

6. Remove the transmission fluid strainer and the O-ring.

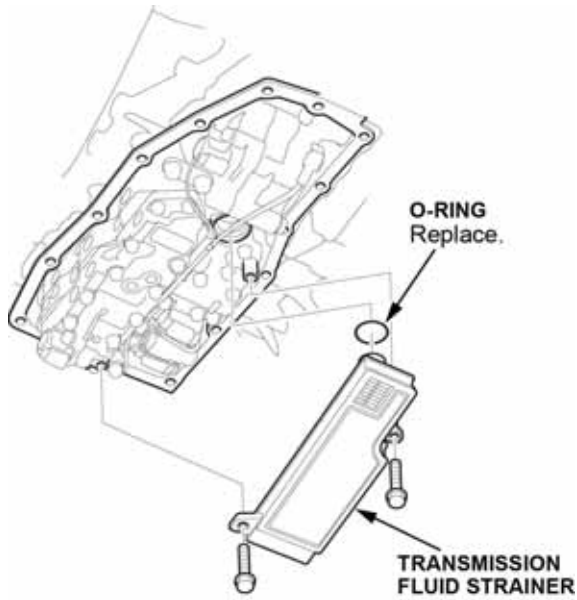

7. Inspect and clean the inlet opening of the transmission fluid strainer as needed. Replace it if it is clogged or damaged.

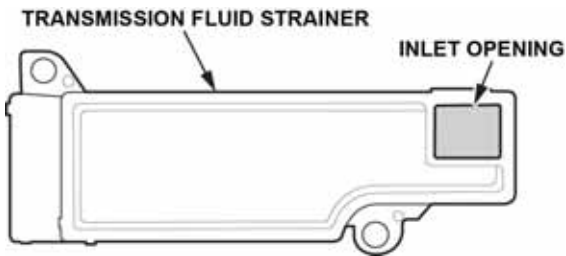

8. Remove the transmission fluid temperature sensor connector. Remove the shift solenoid harness A connector from the harness bracket. Disconnect the following connectors:

- Shift solenoid harness A connector
- Shift solenoid valve B connector
- Shift solenoid valve O/P connector

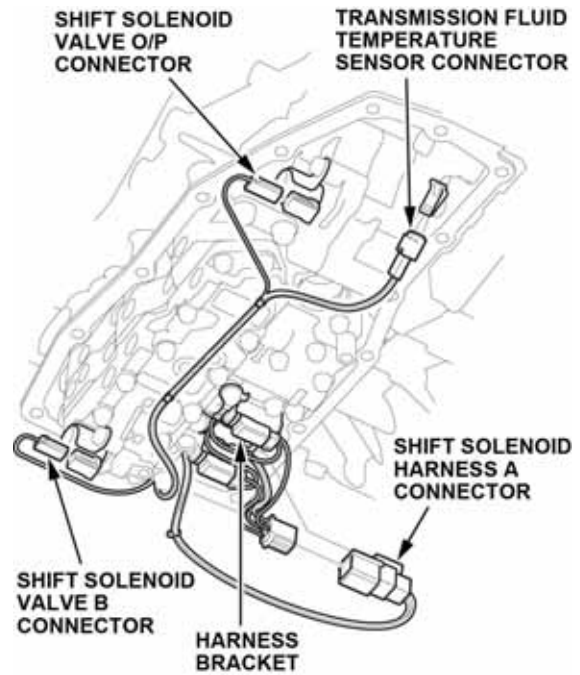

- Remove the guide plate, then remove the lower valve body assembly.

NOTE:

- When removing the valve body assembly, do not damage solenoid wire harnesses A and B.
- Remove only the five valve body bolts and the two guide plate bolts shown. If an incorrect bolt is removed, you may be unable to remove the valve body.

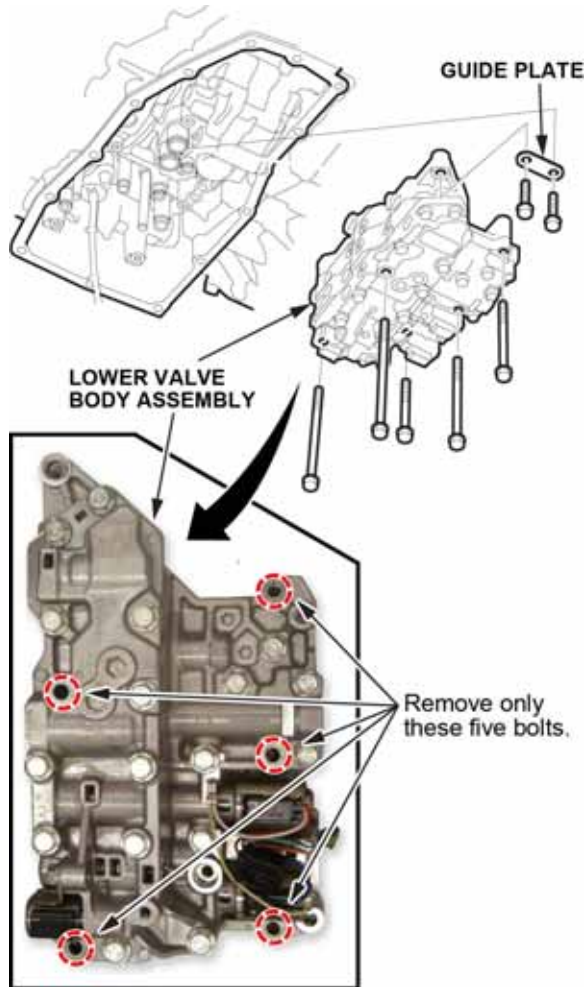

- Remove the 10.9 mm x 25.5 mm pipe and the O-rings.

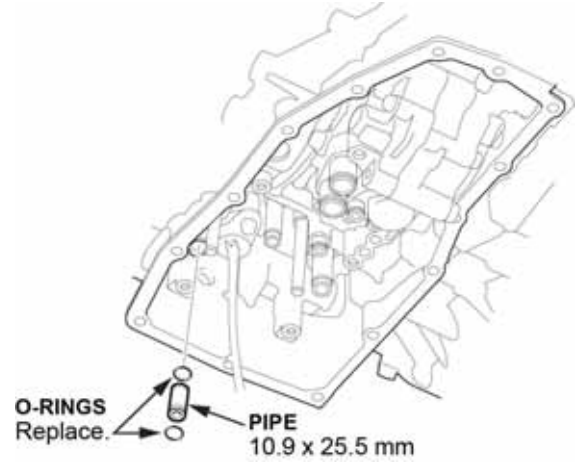

- Remove the 8 mm x 133.5 mm pipe.

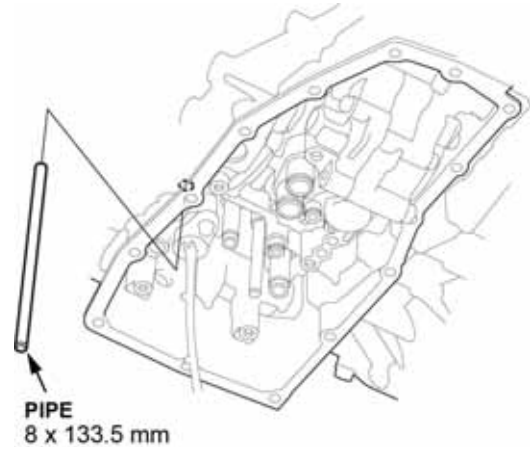

- Remove the 12 mm x 57.5 mm pipe and the O-rings.

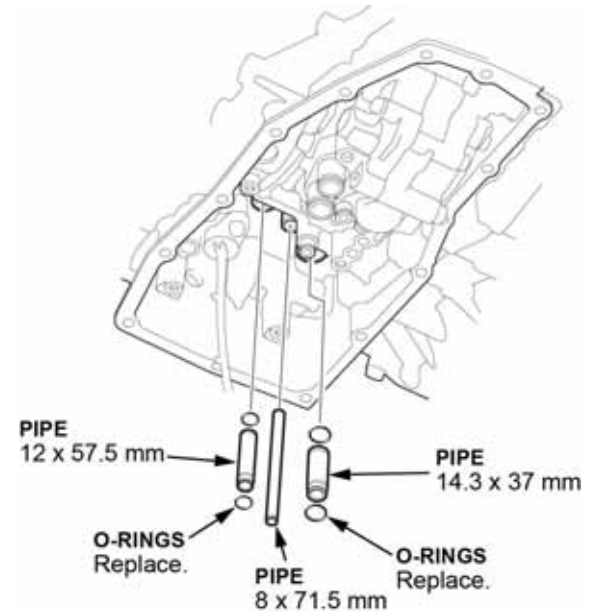

13. Remove the 8 mm x 71.5 mm pipe.
14. Remove the 14.3 mm x 37 mm pipe and the O-rings.
15. Remove the three 10.9 mm x 18.6 mm pipes and the O-rings.

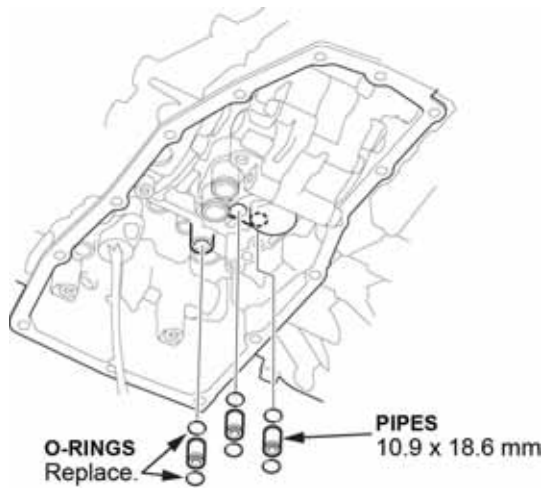

16. Remove the two 18 mm x 18.5 mm pipes and the O-rings.

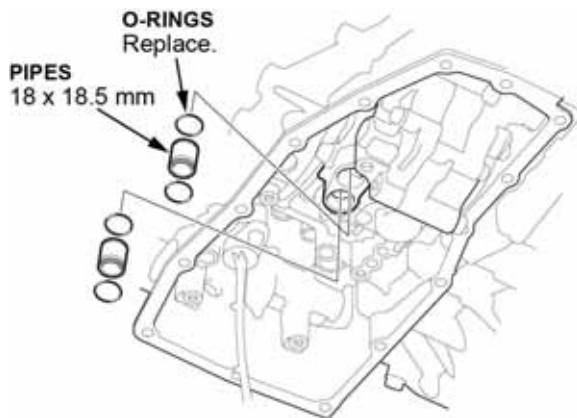

Lower Valve Body Installation

NOTE: Keep all foreign particles out of the transmission.

1. Transfer the 18 mm x 18.5 mm pipes with new O-rings into the new valve body.

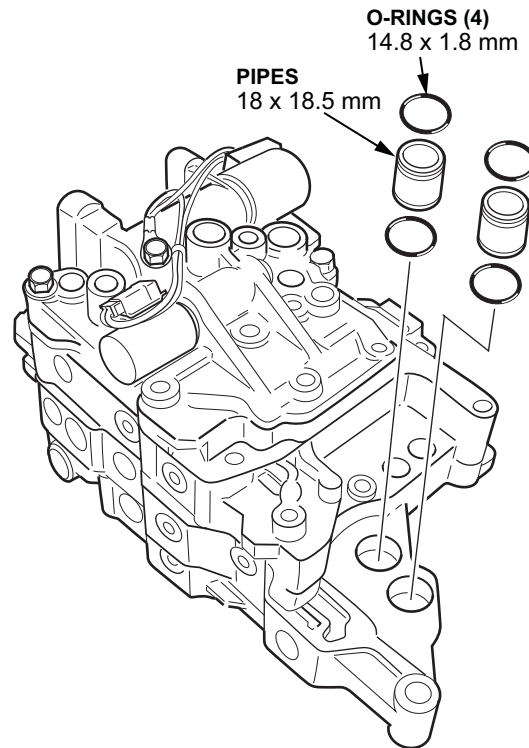

- Transfer the 10.9 mm x 18.6 mm pipes with new O-rings into the new valve body.

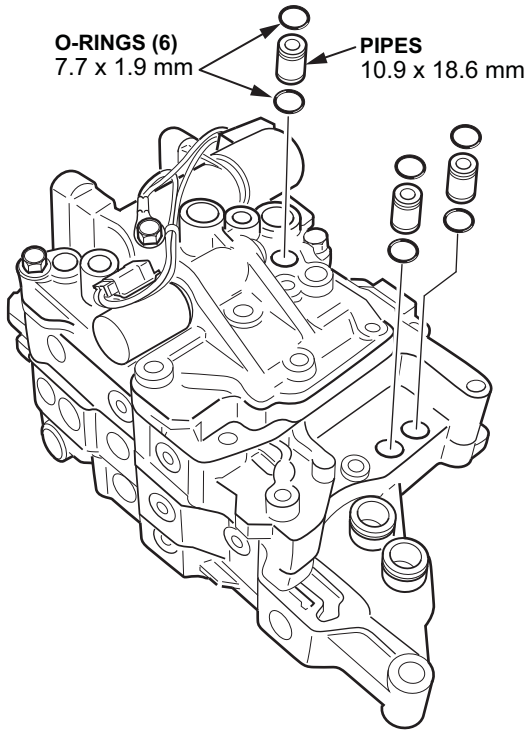

- Transfer the 14.3 mm x 37 mm pipe into the new valve body with new O-rings and with the filter end facing the valve body assembly.

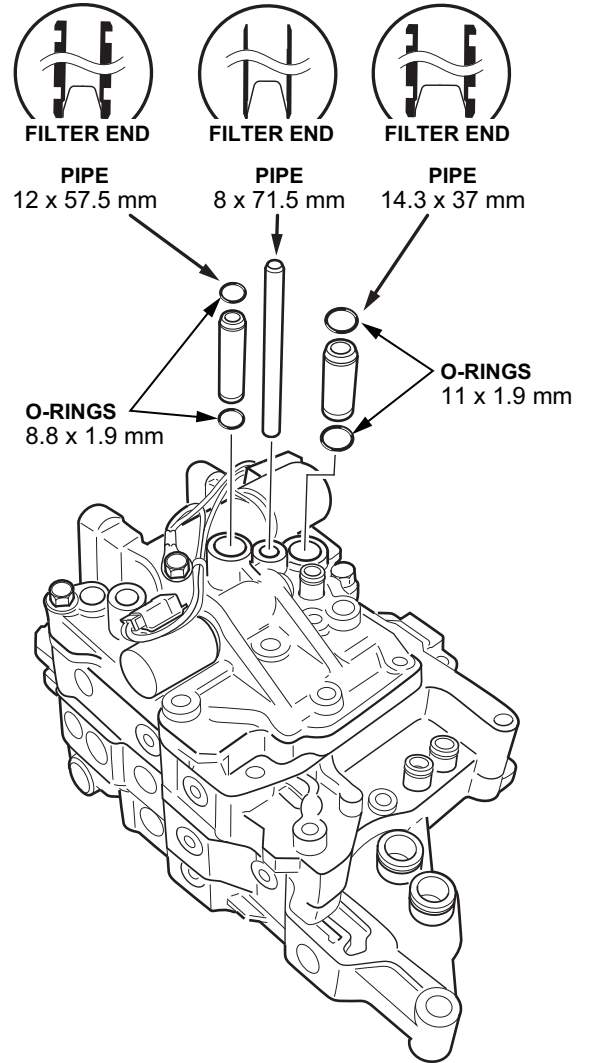

- Transfer the 8 mm x 71.5 mm pipe into the new valve body with the filter end facing the valve body assembly. See diagram in step 3 above.
- Transfer the 12 mm x 57.5 mm pipe into the new valve body using the new O-rings and with the filter end facing the lower valve body assembly. See diagram in step 3 above.
> 8.8 mm x 1.9 mm O-ring (2)

6. Transfer the 8 mm x 133.5 mm pipe into the new valve body.

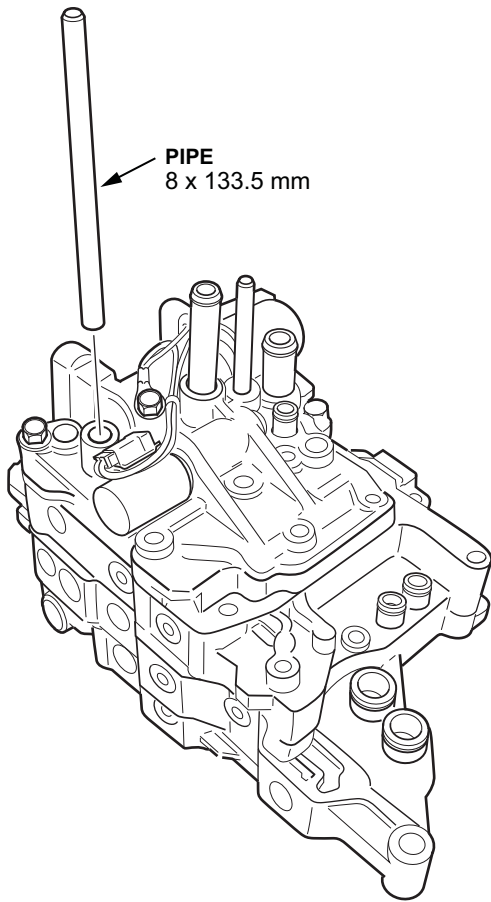

7. Transfer the 10.9 mm x 25.5 mm pipe into the new valve body with new O-rings.

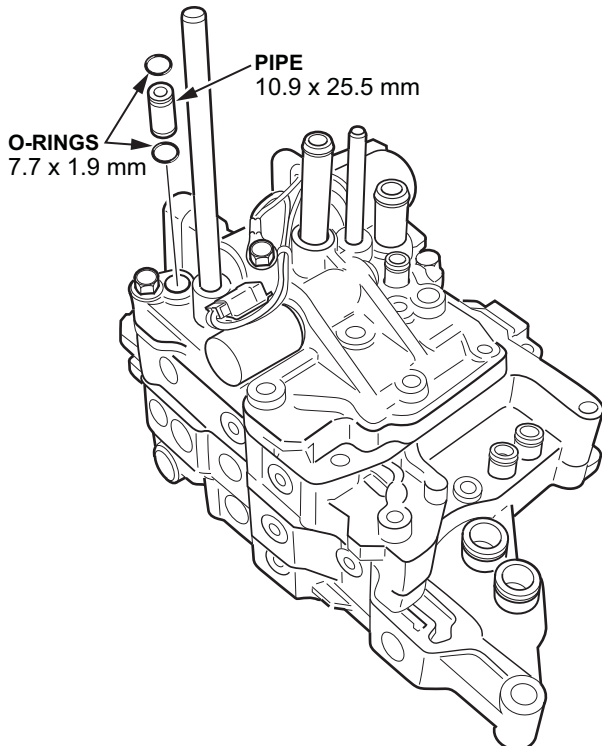

8. Install the new lower valve body assembly and the bolts. Tighten them in a crisscross pattern in at least two steps

NOTE:

- Do not pinch or damage the solenoid wire harnesses.
- While installing the new valve body assembly, be careful not to damage the pipes or the O-rings.

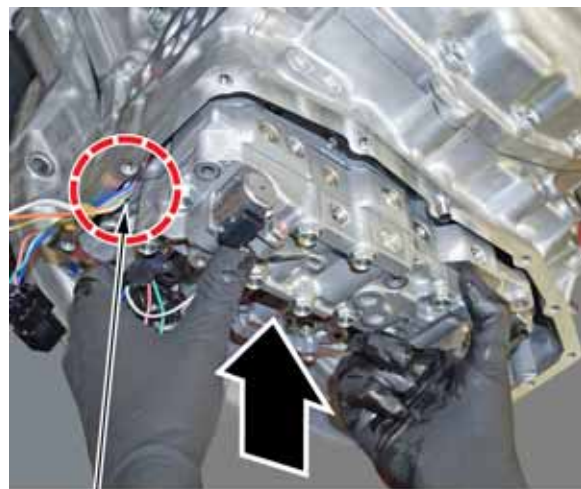
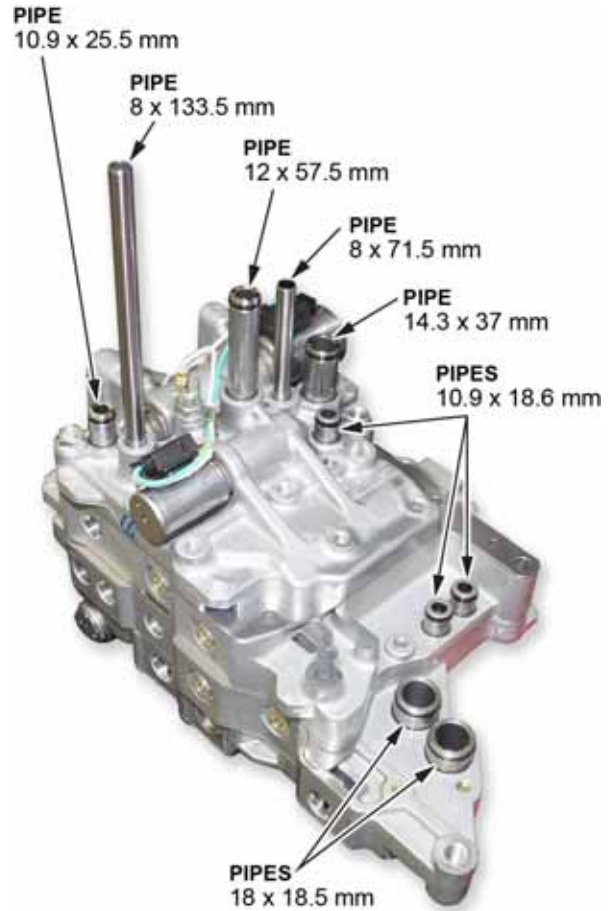

Be careful not to pinch these wires as the valve body is pushed upward.

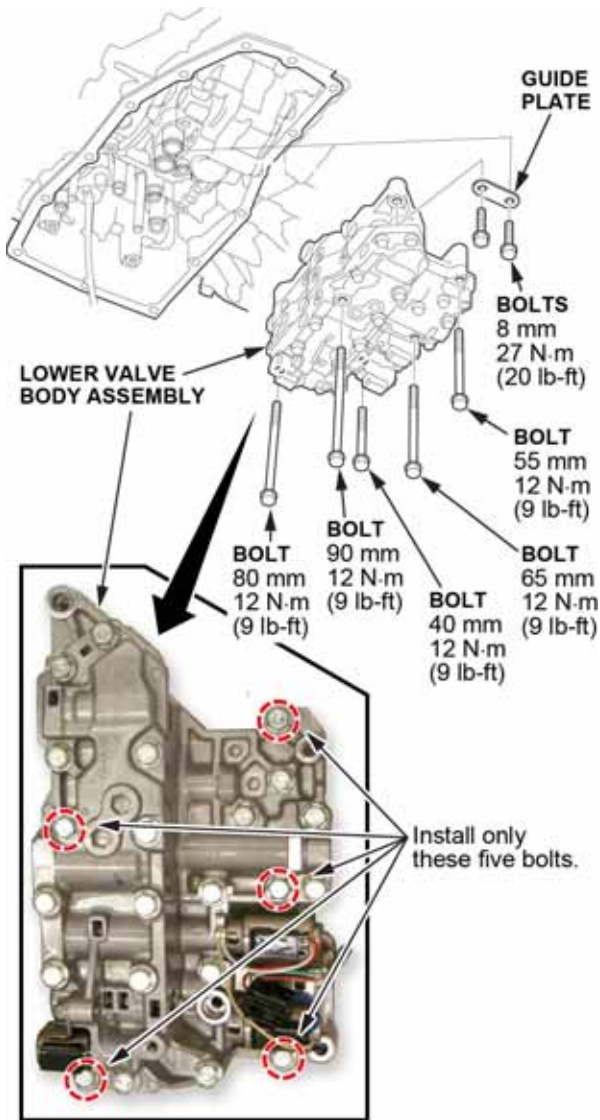

9. Install the guide plate.
10. Connect the following connectors:
 - Shift solenoid harness A connector
 - Shift solenoid valve B connector
 - Shift solenoid valve O/P connector

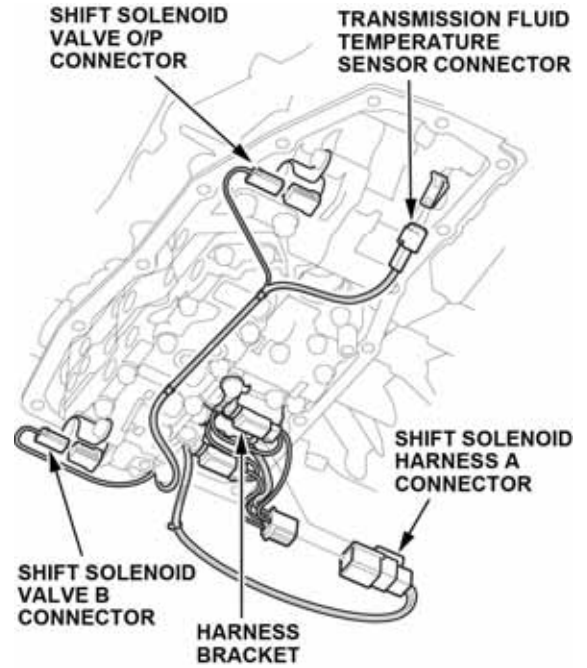

11. Mount the shift solenoid harness A connector to the harness bracket.
12. Connect the transmission fluid temperature sensor connector.

13. Install the transmission fluid strainer with a new O-ring.

NOTE:

- To prevent O-ring damage, carefully install the transmission fluid strainer.
- Do not pinch the solenoid wiring harness.

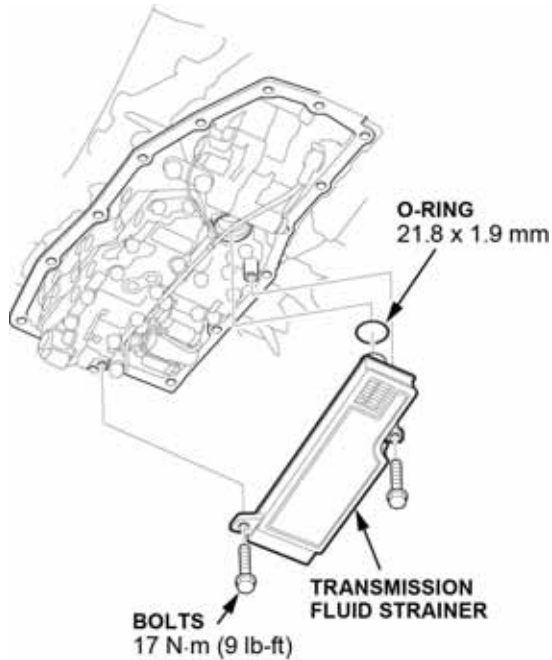

14. Thoroughly clean the fluid pan and magnets (do not remove the magnets). Install the dowel pins, then install the transmission fluid pan with a new gasket. Tighten the bolts in a crisscross pattern in at least two steps.

NOTE:

- Do not pinch or crimp the solenoid wiring harnesses.
- One fluid pan bolt is partially obstructed by the subframe; reinstall and torque it using a 1/4" drive 10 mm swivel socket.

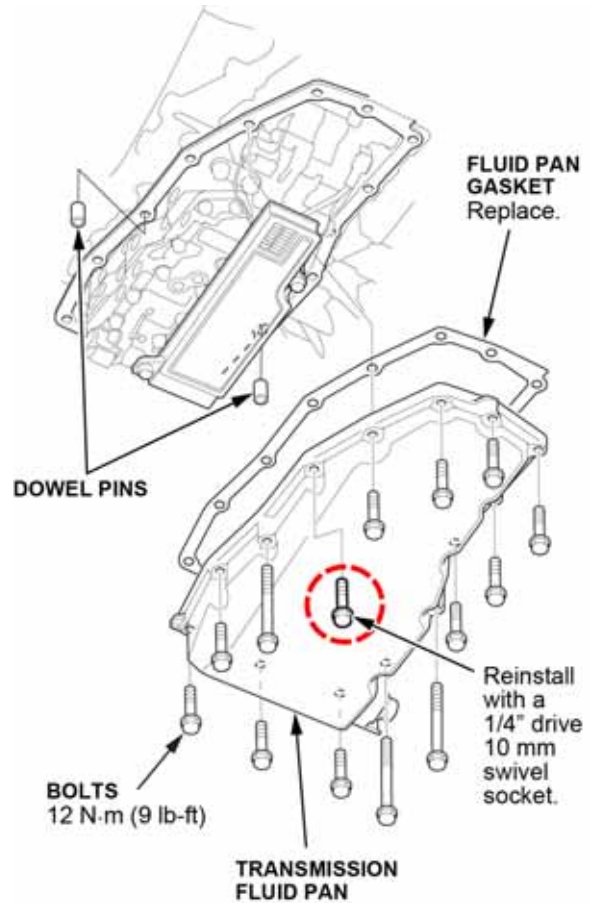

15. Refill the transmission with only Honda HCF-2 CVT Fluid.

NOTE:

- If you use an incorrect fluid, you will damage the transmission.
- **Do not** remove the check bolt before or while refilling the CVT.

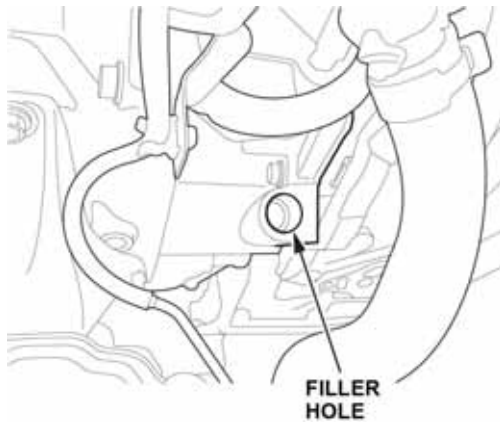

16. Check the CVT fluid level.

CAUTION: The check bolt and the CVT fluid may be hot.

NOTE: When checking the CVT fluid level at the check bolt, it is normal for the CVT fluid to be between the upper or lower level. A slow drip of CVT fluid indicates proper fluid level.

- Do the CVT fluid level check immediately after following the procedure below.
 - Apply the parking brake.
 - Start the engine in Park.
 - While pressing the brake pedal firmly, move the shift lever through all selector positions. Wait for at least 3 seconds in each position.
 - Move the shift lever back to Park.
 - Turn off the engine.
 - Remove the check bolt.
 - Check the transmission fluid level.
 - If necessary, add the proper fluid.

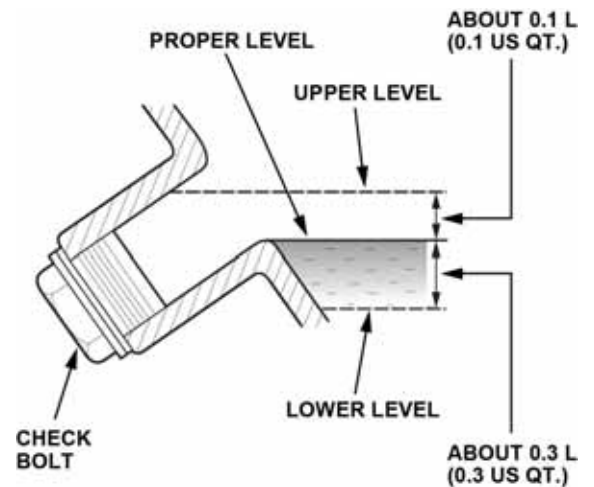

17. Reinstall the check bolt with a new sealing washer.

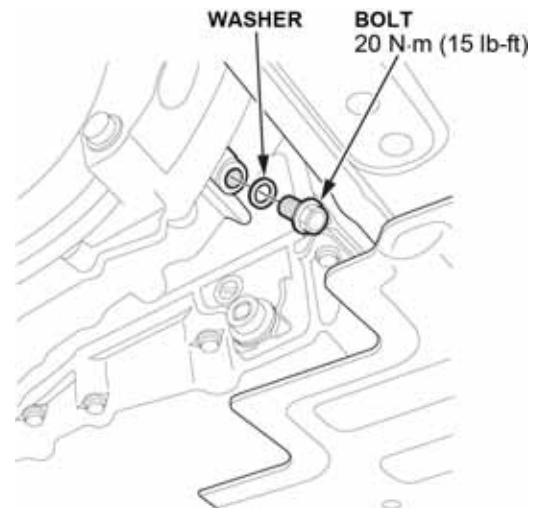

18. Reinstall the engine under cover.
19. Update the PGM-FI Software. Refer to Service Bulletin 01-023, *PCM Software Updating Control Units/Modules*.