

September 16, 2015

02025 Version 3

Safety Recall: Driver's Airbag Inflator Can Be Over-Pressurized

Supersedes 15-040, dated June 9, 2015, to revise the information highlighted in **yellow**

Replaces 14-045, *Recall: Driver's Airbag Inflator May Produce Excessive Pressure After Long-Term Exposure to High Absolute Humidity*

Replaces 15-022, *Recall: Driver's Airbag Inflator May Produce Excessive Pressure After Long-Term Exposure to High Absolute Humidity*

Replaces 10-039, *Safety Recall: Replacement Driver's Airbag Inflator Can Be Over-Pressurized*

Replaces 08-093, *Safety Recall: Driver's Airbag Inflator Can Be Over-Pressurized*

AFFECTED VEHICLES

Year	Model	Trim	VIN Range
2001-07	Accord	ALL	Check the iN VIN status for eligibility
2001-05	Civic	ALL	Check the iN VIN status for eligibility
2001-05	Civic GX	ALL	Check the iN VIN status for eligibility
2003-05	Civic Hybrid	ALL	Check the iN VIN status for eligibility
2002-06	CR-V	ALL	Check the iN VIN status for eligibility
2003-11	Element	ALL	Check the iN VIN status for eligibility
2002-04	Odyssey	ALL	Check the iN VIN status for eligibility
2003-08	Pilot	ALL	Check the iN VIN status for eligibility
2006	Ridgeline	ALL	Check the iN VIN status for eligibility

REVISION SUMMARY

- There are new processes for handling airbag inflators. Refer to **Ordering and Managing Replacement Inflators** for more information on ordering and handling airbag inflators at your dealership. You can find the instructions in two places:
 - On SIS, select **Search By Vehicle**, then **Technical Library**. Enter keyword **INFLATOR** and select **Job Aids**. Select **Ordering and Managing Replacement Inflators** from the list.
 - From the iN, select **Service, Warranty**, then **Claims Reference Guide**. Under **HOT TIPS/TOPICS**, select **Ordering and Managing Replacement Inflators**.
- Under WARRANTY CLAIM INFORMATION, template IDs were added.

BACKGROUND

American Honda consolidated the previous airbag inflator campaigns into this current bulletin based on decisions made by NHTSA. Do an iN VIN status inquiry and, if indicated, repair the vehicle even though the vehicle may have been repaired under a previous campaign.

In certain vehicles, the driver's (front) airbag inflator could produce excessive internal pressure during airbag deployment. If an affected airbag deploys, the increased internal pressure may cause the inflator casing to rupture. Metal fragments could pass through the airbag cushion material, possibly causing injury or fatality to vehicle occupants.

NOTE: If the VIN status inquiry indicates that the vehicle is subject to any open safety recalls, including a front passenger's airbag inflator campaign/recall, make sure to also complete those recall repairs before returning the vehicle to the customer. If you are unable to complete any open recall, advise the customer of the recall status and when the recall could be completed.

CUSTOMER INFORMATION: The information in this bulletin is intended for use only by skilled technicians who have the proper tools, equipment, and training to correctly and safely maintain your vehicle. These procedures should not be attempted by "do-it-yourselfers," and you should not assume this bulletin applies to your vehicle, or that your vehicle has the condition described. To determine whether this information applies, contact an authorized Honda automobile dealer.

New and different inflators are available. You may receive a different part number than ordered, and the inflator may appear different. As a result, there may be different installation instructions. Make sure you review this service bulletin for installation instructions and details about model applicability. PARTS INFORMATION and REPAIR PROCEDURE were updated to reflect these new parts.

On June 18, 2015, there was a change in the return process for driver and front passenger inflators. Refer to PIB A15-0002, *Inflator Kit Return Process* for more information.

CUSTOMER NOTIFICATION

Owners of affected vehicles will receive a notification of this campaign.

Do an iN VIN status inquiry to make sure the vehicle is shown as eligible.

Some vehicles affected by this campaign may be in your used vehicle inventory. These vehicles must be repaired before they are sold.

Should your dealership sell an unrepaired vehicle that subsequently causes injury or damage because of the recalled item, the dealership will be solely responsible to the damaged party, and will be required to defend and indemnify American Honda for any resulting claims. To see if a vehicle in inventory is affected by this recall, do a VIN status inquiry before selling it.

CORRECTIVE ACTION

Replace the driver's airbag inflator, then return the original, undeployed inflator as directed.

NOTE: For Civic models only, inspect the airbag and, if necessary, replace the driver's airbag inflator, then return the original, undeployed inflator as directed.

PARTS INFORMATION

NOTE: Always use new Torx bolts to reinstall the airbags. The new Torx bolts are coated with threadlock to make sure they do not come loose.

Part Name	Order Part Number	You may receive any of the following	Quantity
2001–02 Accord Driver's Airbag Inflator Kit	04770-S5A-305	04770-S5A-305 04770-S5A-405	1
2003–07 Accord Driver's Airbag Inflator Kit	04770-SDA-305	04770-SDA-305 04770-SDA-406	1
2001–05 Civic (includes GX and Hybrid) Driver's Airbag Inflator Kit	04770-S5A-408	04770-S5A-408	1
2002–06 CR-V Driver's Airbag Inflator Kit	04770-S9A-306	04770-S9A-306 04770-S9A-405 04770-S9A-409	1
2003–11 Element Driver's Airbag Inflator Kit	04770-SCV-306	04770-SCV-306 04770-SCV-405 04770-SCV-409	1
2002–04 Odyssey Driver's Airbag Inflator Kit	04770-S5A-305	04770-S5A-305 04770-S5A-405	1
2003–08 Pilot Driver's Airbag Inflator Kit	04770-S9A-306	04770-S9A-306 04770-S9A-405 04770-S9A-409	1
2006 Ridgeline Driver's Airbag Inflator Kit	04770-SJC-306	04770-SJC-306 04770-SJC-406	1
Torx Bolts (For reinstalling Autoliv airbags only)	90134-S04-A81	N/A	2

NOTE:

- The inflator kit box must be used to return the old inflator to its supplier. Be careful not to damage the inflator kit box.
- If the defective, undeployed inflator is not returned, the warranty claim for that vehicle will be charged back to your dealership.
- To return the inflator, follow the instructions in PIB A15-0002, *Inflator Kit Return Process*.
- Parts staff can scan the part number and serial number from the outside of the box into the warranty claim by using the Controlled Part Serial No. screen and scanning the applicable information. Refer to the Job Aid **Ordering and Managing Replacement Inflators** for more information.

WARRANTY CLAIM INFORMATION

NOTE:

- **Use the Autoliv claim for removing and reinstalling Autoliv airbags only.** Do not use it to claim any labor on Takata airbags.
- To avoid a warranty claim being charged back to your dealership, the defective, undeployed inflator must be returned to its supplier. Follow the shipping instructions in PIB A15-0002, *Inflator Kit Return Process*.
- The **replacement inflator part number and serial number** are printed on the label that should be attached to the RO.
- To avoid non-payment of warranty claims, the new airbag inflator part number and serial number must be included in each claim. For more information, refer to step 7 of REPAIR PROCEDURE.
- The serial number is encoded into the bar code printed on the label inside of the box and on a label attached to the outside of the box. If your dealership uses a scanner, you can scan the serial number from either place into the claim.
- The part number is encoded into a barcode attached to the outside of the box. If your dealership uses a scanner, you can scan the part number into the claim.
- **If you confuse the serial number and part number when entering the claim information, your claim will automatically be rejected.**
- For more information about scanning and filing airbag inflator recall claims, refer to **Ordering and Managing Replacement Inflators**. From the iN, select **Service, Warranty**, then **Claims Reference Guide**. Under **HOT TIPS/TOPICS**, select **Ordering and Managing Replacement Inflators**.

Year/Model	Operation Number	Replacement Part Number	Flat Rate Time	Defect Code	Symptom Code	Template ID	Failed Part Number
2001–02 Accord	7521H8	04770-S5A-305	0.5 hr	5VZ00	JQ900	15-040A	06770-SDA-A80ZA
		04770-S5A-405				15-040B	
2003–07 Accord	7521H8	04770-SDA-305	0.5 hr	5VZ00	JQ900	15-040C	06770-SDA-A80ZA
		04770-SDA-406				15-040D	
2001–05 Civic	7521H8	04770-S5A-408	0.5 hr	5VZ00	JR000	15-040E	06770-S5A-A10ZA
2001–05 Civic GX	7521H8						
2003–05 Civic Hybrid	7521H8						
2002–06 CR-V	7521H8	04770-S9A-306	0.5 hr	5VZ00	JR100	15-040F	06770-S9A-A80ZA
		04770-S9A-405				15-040G	
		04770-S9A-409				15-040H	
2003–11 Element	7521H8	04770-SCV-306	0.5 hr	5VZ00	JR200	15-040I	06770-SCV-A80ZA
		04770-SCV-405				15-040J	
		04770-SCV-409				15-040K	
2002–04 Odyssey	7521H9	04770-S5A-305	0.5 hr	5VX00	JR300	15-040L	06770-S0X-A10ZA
		04770-S5A-405				15-040M	
2003–08 Pilot	7521H9	04770-S9A-306	0.5 hr	5VX00	JR400	15-04N0	06770-S9V-A01ZA
		04770-S9A-405				15-040O	
		04770-S9A-409				15-040P	
2006 Ridgeline	7521H9	04770-SJC-306	0.5 hr	5VX00	JR500	15-040Q	06770-SJC-A10ZA
		04770-SJC-406				15-040R	

Remove and Reinstall Autoliv Airbags Only

2001–05 Civic	7521J0	N/A	0.3 hr	5VZ00	JR000	15-040S	06770-S5A-A10ZA
---------------	--------	-----	--------	-------	-------	---------	-----------------

REPAIR PROCEDURE

NOTE:

- If the VIN status inquiry indicates that the vehicle is subject to any open safety recalls, including a passenger's airbag inflator campaign/recall, make sure to also complete those recall repairs before returning the vehicle to the customer. If you are unable to complete any open recall, advise the customer of the recall status and when the recall could be completed.
 - Be careful not to damage any parts when replacing the inflator, and **follow the procedure exactly**.
 - If, before removing the airbag, you suspect that it may be the incorrect airbag for the vehicle or a counterfeit, **do not remove the airbag**. Contact your DPSPM for assistance.
 - Do not open the inflator kit until you have confirmed a Takata inflator is installed in the vehicle because if you have to return the inflator kit, the kit must be unopened.
 - If the vehicle you are working on has an Autoliv airbag and inflator, **do not disassemble the airbag** because the inflator cannot be reinstalled, and you will have to replace the airbag module.
 - Make sure you have reviewed the SRS Precautions and Procedures in the applicable electronic service manual before doing the REPAIR PROCEDURE.
1. Turn the ignition switch to the ON (II) position and check if the SRS indicator comes on for about 6 seconds, then turns off.
 - If the indicator comes on, then turns off after about 6 seconds, go to step 2.
 - If the indicator does not come on, or if it stays on, contact your DPSPM for assistance.
 2. Disconnect the battery negative cable and wait at least 3 minutes before continuing.
 3. Remove the driver's airbag. Refer to the applicable electronic service manual.
 4. Place the airbag, face down, on a clean shop towel.
 5. Visually inspect the airbag and the inflator for any unusual writing or markings.
 - If there is nothing unusual about the airbag or the inflator, go to step 6.
 - If there are any unusual markings, like an incorrect label or a model year written in marker, the airbag and inflator may not be the correct airbag and/or inflator for the vehicle or it may be a counterfeit part. For more information about counterfeit airbags, you can refer to safercar.gov, enter keywords **MANAGING COUNTERFEIT**, and select **Recommended Dealer Guidance for Managing Counterfeit Air Bags** from the list. **If you suspect that the airbag or inflator is counterfeit, do not continue this procedure.** Contact your DPSPM for assistance.

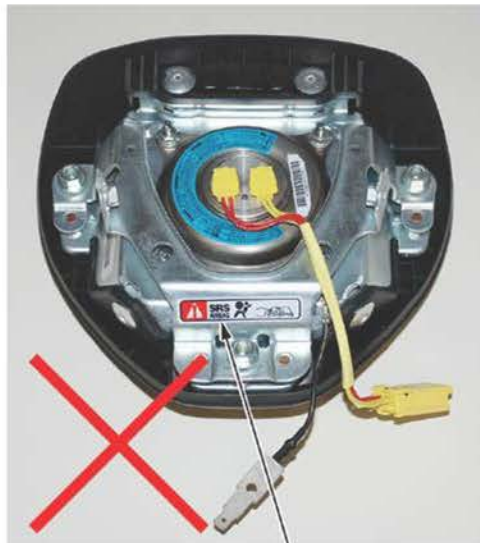

NON-STANDARD
SAFETY LABEL



NON-STANDARD
WIRES

6. **Civic only** - Determine if the airbag is made by Autoliv or Takata by comparing the inflators to those in the images below.

NOTE: The Autoliv serial number label is different from the Takata label; the Autoliv has 11 characters, the Takata has 9.

- If the airbag is made by Autoliv, the airbag is OK. Reinstall the airbag using new Torx bolts. Torque the bolts to **9.8 N-m (7.2 lb-ft)**. If you already received a replacement inflator, return the unopened kit to American Honda.
- If the airbag is made by Takata, go to step 7.



7. Peel the label located inside the inflator box from its backing and attach it to the RO. For the warranty claim to be paid, the **replacement inflator part number that you received** must be included in the warranty claim.

NOTE:

- The replacement part number is printed on the top part of the label and the serial number is printed on the bottom. **Make sure you attach the label to the RO and give it to the warranty clerk.**
- There may also be a colored sticker located in the kit, ignore it because it is not used.
- Not all inflator kits have a label included. In those cases, write the serial number and part number from the side of the inflator box on the RO. The part number always starts with 047.

INFLATOR PARTS BOX

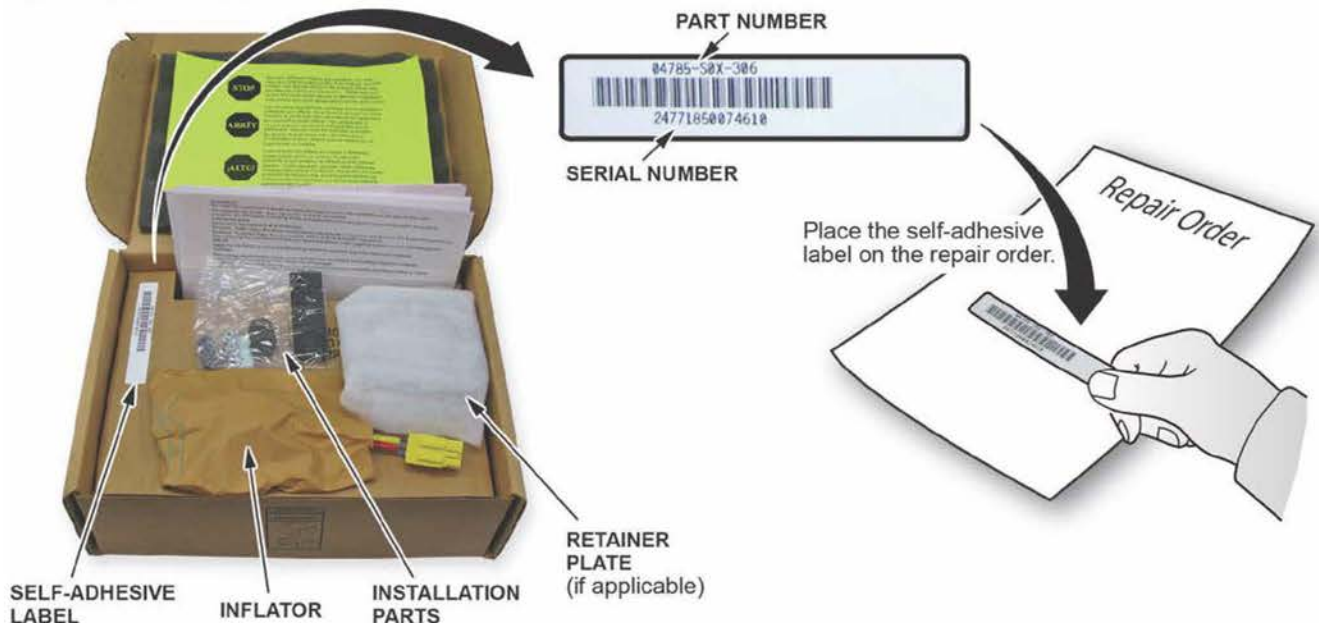

8. If there is no horn plate installed, go to step 9. If there is a horn plate installed, remove the four horn plate mounting bolts, the mounting bolt felt washers, the horn plate, and remove the felt tape covering the lower two inflator locknuts. The felt washers and felt tape will not be reused.

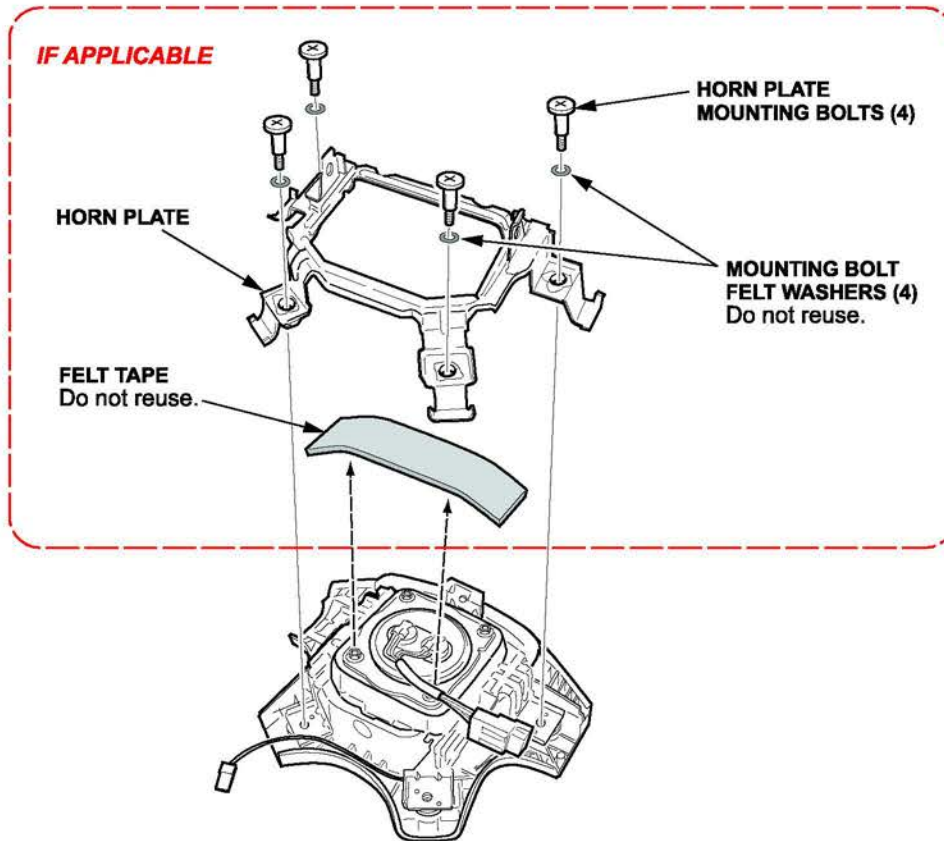

9. Using needle-nose vise grips or a 3/8 in. 6-point socket, remove the four locknuts from the inflator. The locknuts will not be reused.

NOTE: Do not remove the inflator from the airbag until you complete step 10.

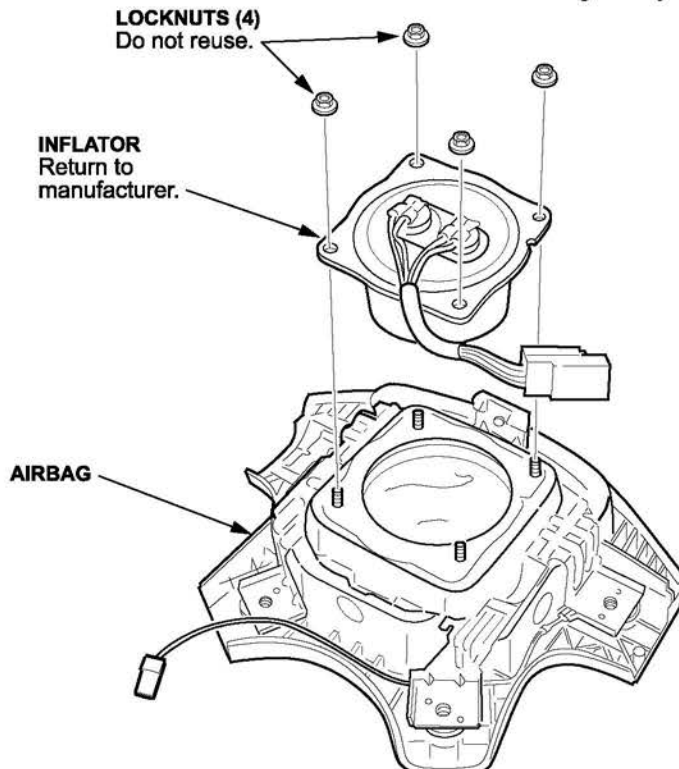

10. Use shop air to clean any debris that may be on the inflator, then remove the inflator from the airbag.

NOTE:

- Do not allow any debris to enter the inflator opening in the airbag.
- Do not deploy the inflator. The inflator must be returned to its supplier in the box the new inflator came in. Follow the shipping instructions supplied with the inflator kit. If you have any questions about shipping, call Warranty Parts Inspection (WPI) at **937-642-2737**.

11. Turn over the airbag (inflator side down), and shake it to remove any debris from the inflator opening.

12. Install the new inflator in the airbag.

NOTE: There may be some minor surface rust or corrosion on the new inflator; this is OK.

Click on the image below for a short video about the different variations of the driver's and front passenger's replacement inflators involved with the recalls related to Takata inflators. While both the driver's and front passenger's inflators are shown in the video, this is informational only. Replace inflators only as directed by the iN VIN status inquiry.



Check your part number against the ones listed for each installation procedure. Use the correct installation procedure for the part you received.

Part Number

04770-S5A-305

04770-SDA-305

04770-S9A-306

04770-SCV-306

04770-SJC-306

Refer to **Driver's Inflator Type 1** in the video.

- Insert the inflator into the opening.

NOTE: Make sure the inflator wires are positioned toward the bottom of the airbag. If you install the inflator incorrectly, you may not be able to reconnect the SRS airbag harness.

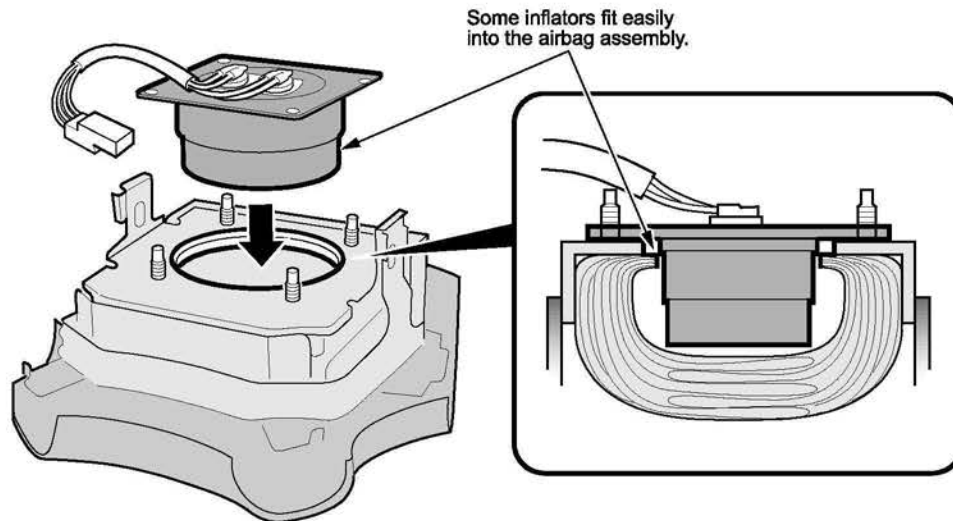

Check your part number against the ones listed for each installation procedure. Use the correct installation procedure for the part you received.

Part Number

04770-S5A-405

04770-SDA-406

04770-S9A-405

04770-SCV-405

04770-SJC-406

Refer to **Driver's Inflator Type 2** in the video.

- Insert the inflator into the opening. Do not force it into the airbag module.

NOTE: Make sure the inflator wires are positioned toward the bottom of the airbag. If you install the inflator incorrectly, you may not be able to reconnect the SRS airbag harness.

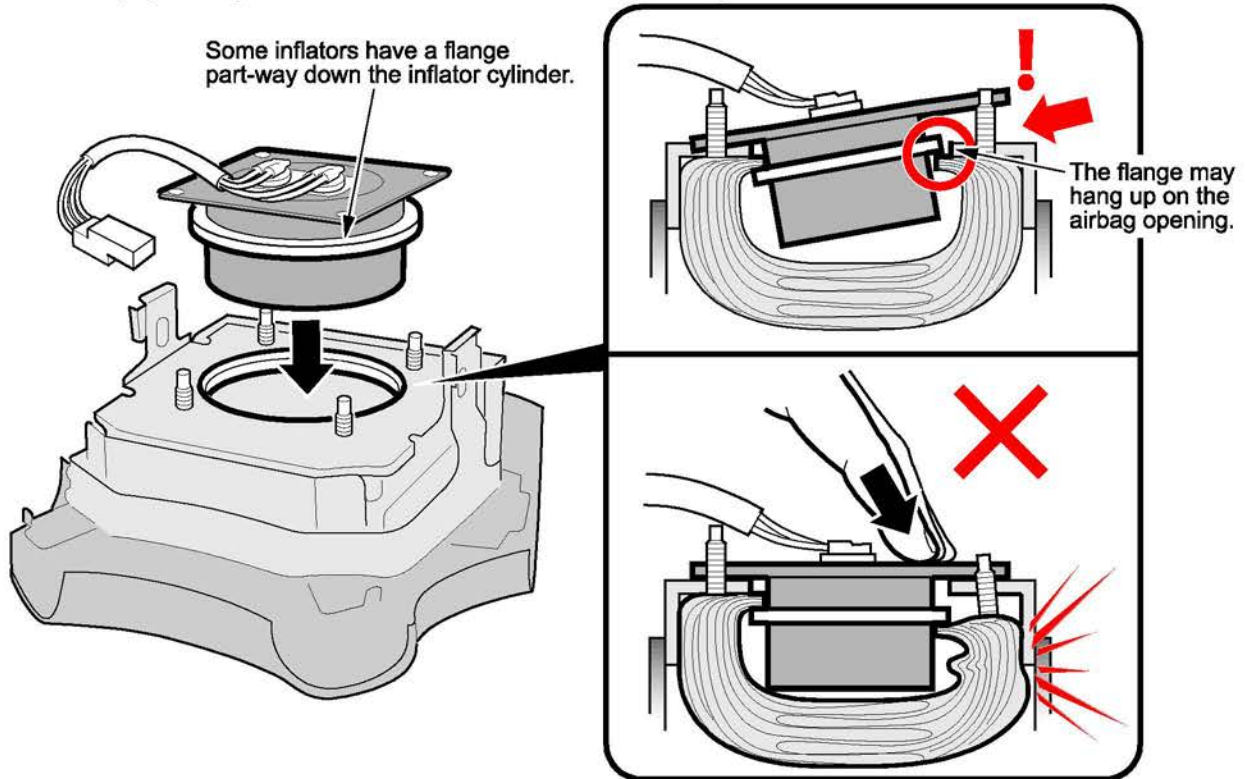

- Using a pair of pliers, gently pull up on each stud up while pushing the inflator module down until the airbag is properly seated within the airbag module.

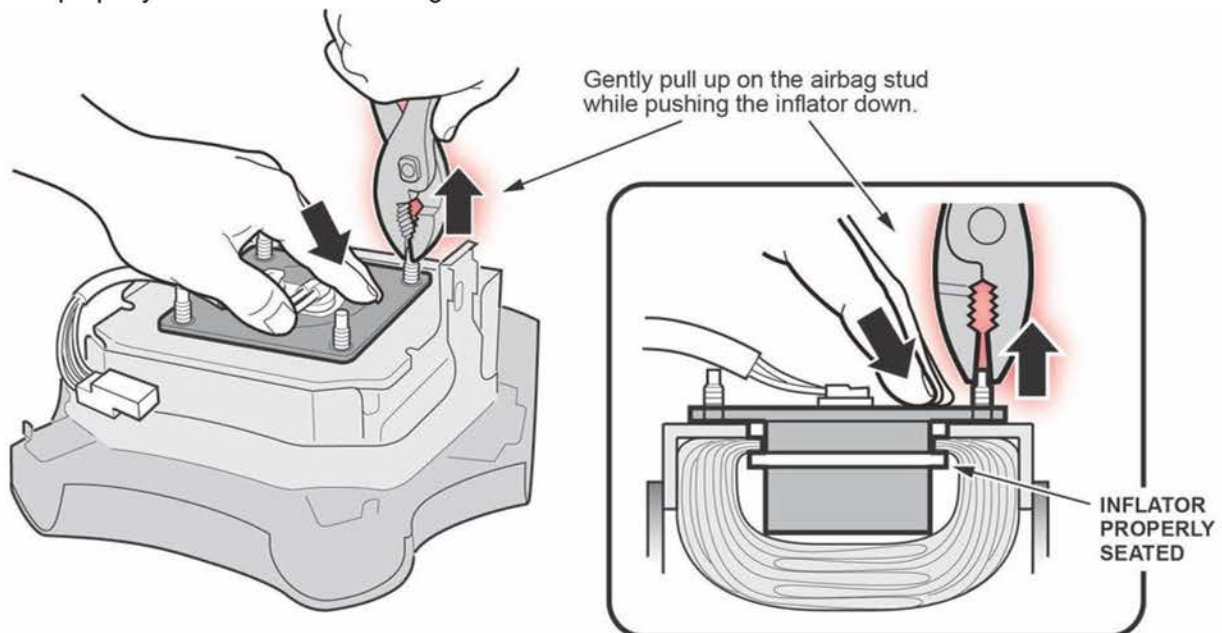

Check your part number against the ones listed for each installation procedure. Use the correct installation procedure for the part you received.

Part Number

04770-S5A-408

Refer to **Driver's Inflator Type 3** in the video.

The inflator is held down by a directional retainer that is keyed to the inflator.

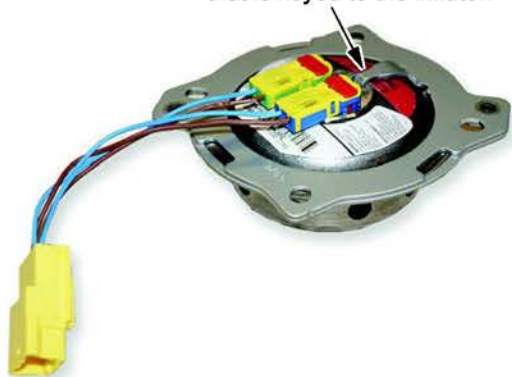

- Place the inflator into the opening with the inflator harness toward the bottom of the airbag.

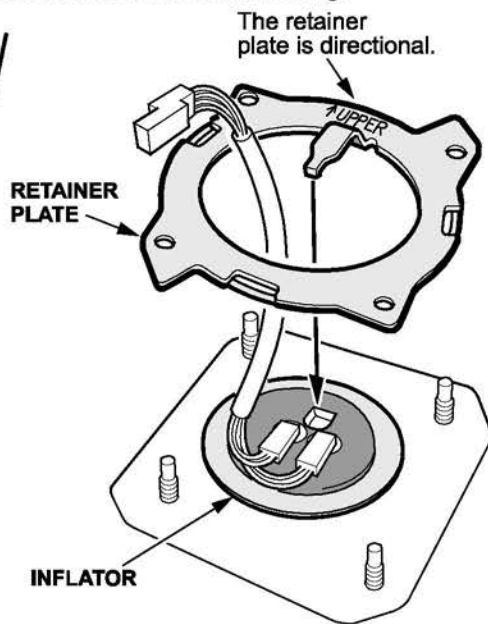
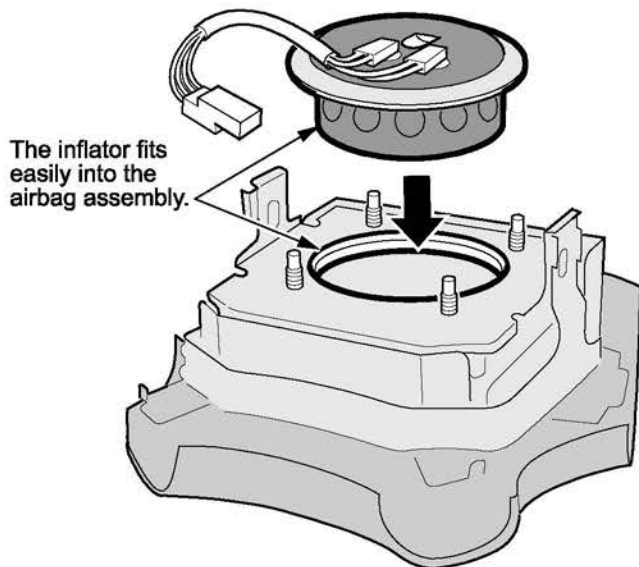

- Install the bracket onto the studs. Make sure the locator tab fits into the locator hole as shown.
NOTE: Make sure the harness comes out through the center opening. Do not install the bracket over the harness wires.

Check your part number against the ones listed for each installation procedure. Use the correct installation procedure for the part you received.

Part Number

04770-S9A-409

Refer to **Driver's Inflator Type 4** in the video.

04770-SCV-409

The inflator is held down by a directional retainer that is keyed to the inflator.

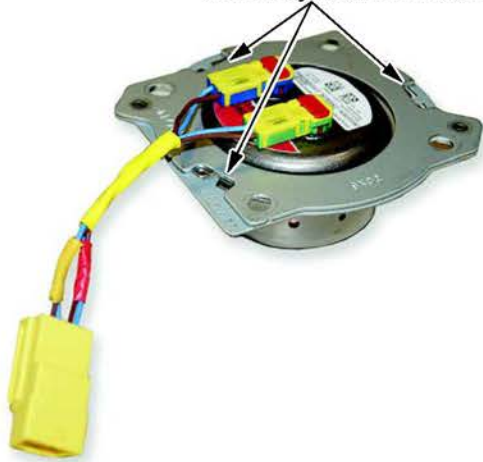

- Place the inflator into the opening with the inflator harness toward the bottom of the airbag.

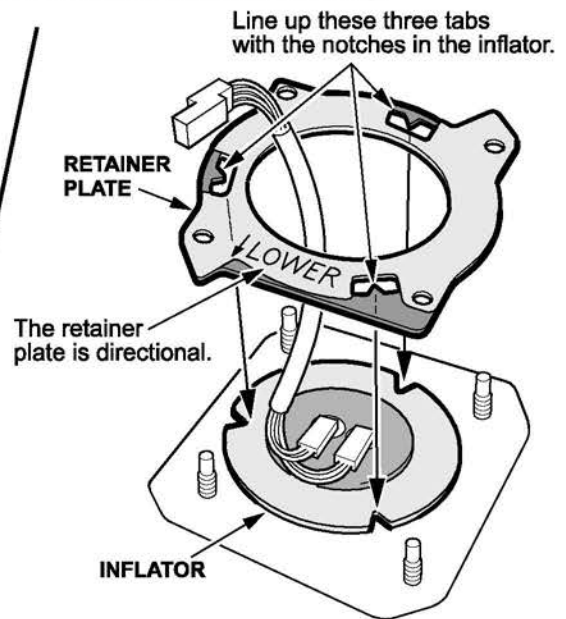
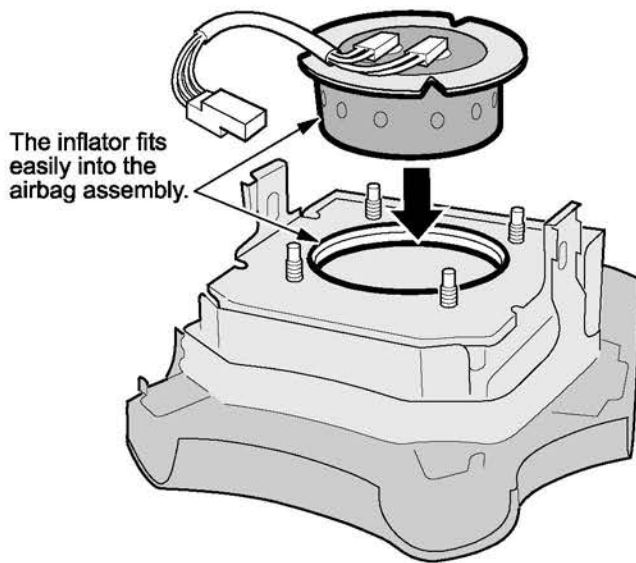

- Install the bracket onto the studs with the stamp **LOWER** at the bottom of the airbag.
- Make sure the three tabs and notches are properly aligned.

NOTE:

- The tabs and notches are designed to align in one direction only. If the tabs and notches are not aligned, the inflator and bracket are not installed correctly.
- Make sure the harness comes out through the center opening. Do not install the bracket over the harness wires.

13. Install and torque the new locknuts to **3.9 N·m (2.8 lb-ft, 34 lb-in)**.
14. If applicable, cover the lower two inflator locknuts with new felt tape.
15. If applicable, reinstall the horn plate with new felt washers on its mounting bolts. Torque the mounting bolts to **3.4 N·m (2.5 lb-ft, 30 lb-in)**, then make sure the horn plate moves freely.
16. Reinstall the driver's airbag using new Torx bolts and torque the bolts to **9.8 N·m (7.2 lb-ft)**. Refer to the applicable electronic service manual.
17. Reconnect the battery negative cable.
18. Start the vehicle and check that the SRS indicator comes on for about 6 seconds, then turns off.
19. Give your warranty clerk the RO that includes the replacement inflator serial number and replacement part number. For the warranty claim to be paid, the **replacement inflator part number** must be included in the warranty claim.

END