

August 28, 2015

02206 Version 1

Transmission End Cover Leaks (9-Speed A/T)

AFFECTED VEHICLES

Year	Model	Trim	VIN Range
2015	TLX	ALL with 9-speed A/T	ALL
2016	MDX	ALL with 9-speed A/T	ALL

SYMPTOM

The transmission end cover leaks on vehicles with 9-speed A/T.

POSSIBLE CAUSES

During assembly, the transmission end cover sealing gasket gets torn.

CORRECTIVE ACTION

Replace the transmission end cover sealing gasket.

REQUIRED MATERIALS

Part Name	Part Number	Quantity
ATF Type 3.0	08200-9016A	1

PARTS INFORMATION

Part Name	Part Number	Quantity
End Cover Kit: (contains 11 Torx bolts, cover, seal, and plugs)	06233-5J4-000	1

CLIENT INFORMATION: The information in this bulletin is intended for use only by skilled technicians who have the proper tools, equipment, and training to correctly and safely maintain your vehicle. These procedures should not be attempted by "do-it-yourselfers," and you should not assume this bulletin applies to your vehicle, or that your vehicle has the condition described. To determine whether this information applies, contact an authorized Acura automobile dealer.

WARRANTY CLAIM INFORMATION

The normal warranty applies.

WARRANTY CLAIM INFORMATION (TLX)

Operation Number	Description	Flat Rate Time	Template ID	Failed Part Number
2321S2	Replace the transmission end cover sealing gasket (TLX) (includes ATF level check).	1.1 hrs	15-039N	20021-5NB-053

WARRANTY CLAIM INFORMATION (MDX)

Operation Number	Description	Flat Rate Time	Template ID	Failed Part Number
2321S2	Replace the transmission end cover sealing gasket (MDX) (includes ATF level check).	1.0 hrs	15-039P	20021-5NB-043

Defect Code: 07408

Symptom Code: 05103

Skill Level: Repair Technician

REPAIR PROCEDURE

1. Raise the vehicle on a lift.
2. *TLX Only:* Remove the undercover.

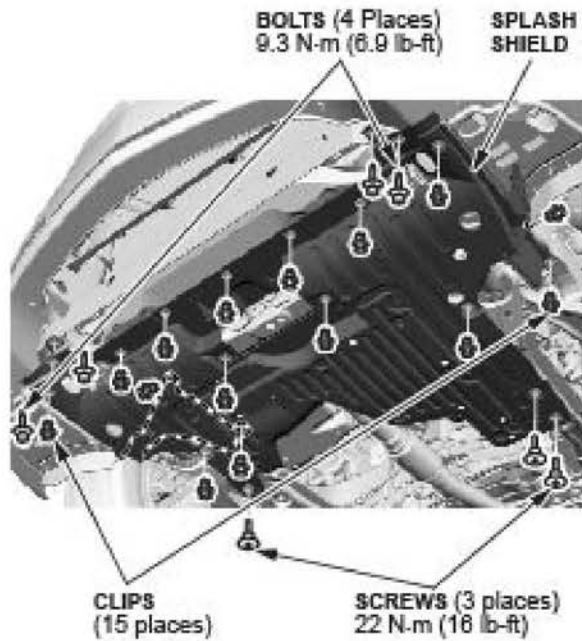

3. Loosen and remove the fender liner as needed to access the transmission end cover.

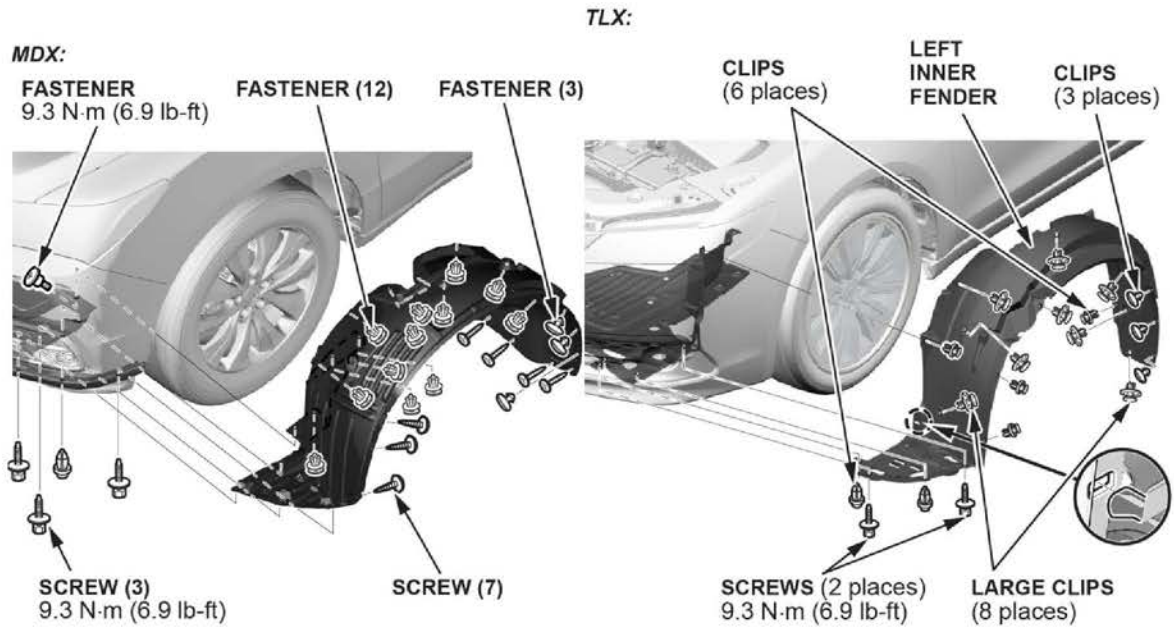

4. Use a strap to hold the fender liner out of the way.
5. *TLX Only:* Remove the resonator box and move the intake tube.



6. Remove the 11 T-30 Torx bolts from the end cover.

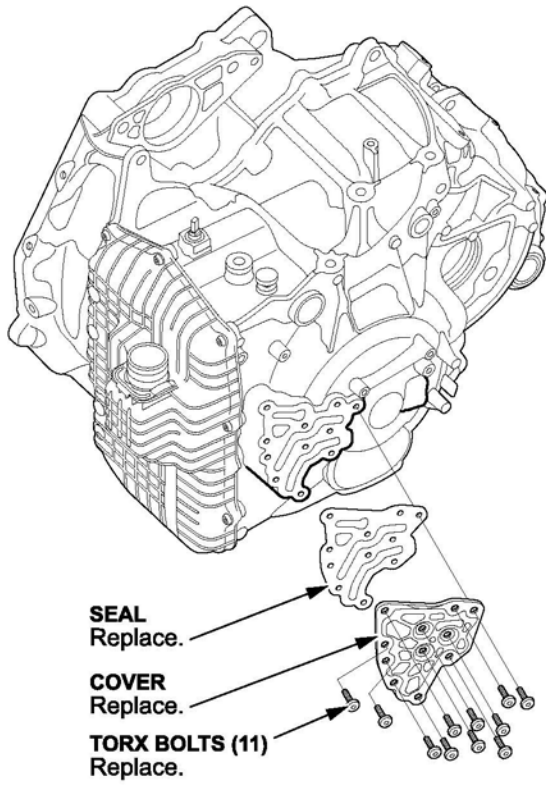

7. Replace the cover, the sealing gasket, and bolts with the new ones from the kit. Torque the bolts to **10.0 N·m (7 lb-ft)** in the sequence shown.

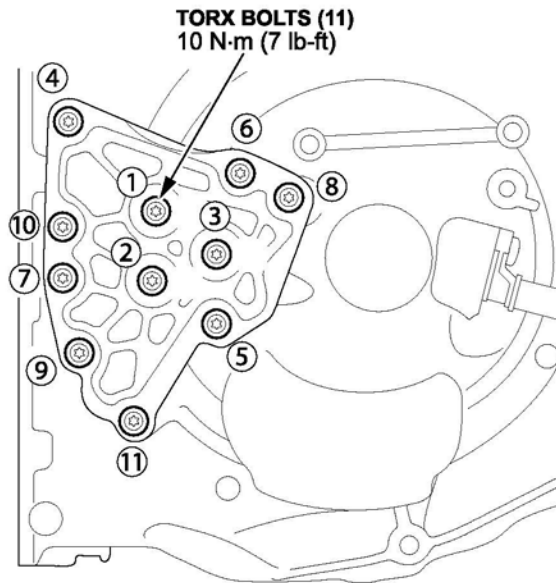

8. Reinstall the fender liner.
9. *TLX Only:* Reinstall the resonator box, intake tube, and undercover.

ATF LEVEL CHECK

1. Make sure the vehicle is raised so the wheels are just off the ground.
2. Turn the ignition to the ON.
3. Enter the VSA maintenance mode.
4. Start the engine.
5. Shift the transmission to Drive, then select the Sport+ mode by pressing the integrated dynamics system switch.
6. Run the transmission in 1st gear, 2nd gear, 3rd gear, and 4th gear, and waiting 10 seconds in each gear. Slow down, and stop the wheels.

NOTE: Do not run the transmission on the lift past 4th gear or damage will occur.

7. Shift the transmission to Park, then raise the engine speed at 2,000 rpm to ensure that the torque converter is full of ATF.
8. Run the engine at idle speed until ATF temperature reaches 104° F (40° C) (allowed adjusting range: 99–113° F (37–45 °C) with the HDS).
9. While the engine is running, remove the level plug and make sure the ATF is dripping from the level plug hole.

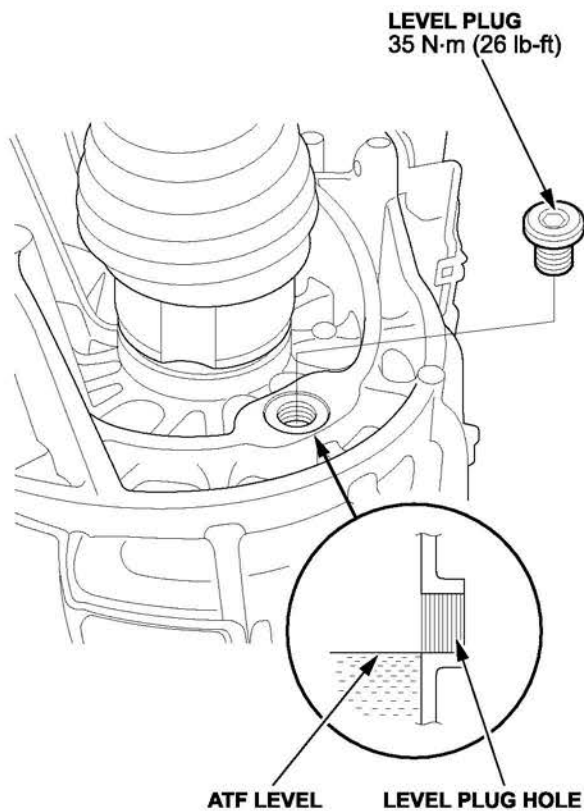

10. If the ATF is pouring out, wait until the ATF starts dripping from the level plug hole.
11. If there is no ATF coming out, add the ATF through the level plug hole until the ATF overflows, then wait until the ATF starts dripping from the level plug hole.

NOTE: Improper ATF level will affect shift quality.

12. Install a new level plug and torque it to **35 N·m (26 lb-ft)**.
13. Turn the engine off.

END