

March 31, 2017

06121 Version 3

Slapping or Clicking From Engine Area at Idle

 Supersedes 14-030, dated June 18, 2014, to revise the information highlighted in **yellow**.

AFFECTED VEHICLES

Year	Model	Trim	VIN Range
2013	Accord	L4	ALL
2014	Accord	2-Door L4 EX-L	1HGCT1B8.EA000001 thru 1HGCT1B8.EA006773
2014	Accord	2-Door L4 LX-S	1HGCT1B3.EA000001 thru 1HGCT1B3.EA006694
2014	Accord	2-Door L4 EX	1HGCT1B7.EA000001 thru 1HGCT1B7.EA006524
2014	Accord	4-Door L4 LX	1HGCR2F3.EA000001 thru 1HGCR2F3.EA120107
2014	Accord	4-Door L4 EX	1HGCR2F3.EA000001 thru 1HGCR2F3.EA123948
2014	Accord	4-Door L4 EX-L	1HGCR2F8.EA000001 thru 1HGCR2F8.EA123438
2014	Accord	4-Door L4 Sport	1HGCR2F5.EA000001 thru 1HGCR2F5.EA123058

REVISION SUMMARY

Under **REQUIRED MATERIALS**, the oil was changed to Full Synthetic Engine Oil, P/N 08798-9063.

SYMPTOM

There is a slapping or clicking from the engine area at idle.

POSSIBLE CAUSE

Debris may be restricting oil flow to the cam chain auto-tensioner.

CORRECTIVE ACTION

Replace the cam chain auto-tensioner, and install a cam chain auto-tensioner filter.

PARTS INFORMATION

Part Name	Part Number	Quantity
Cam Chain Auto-Tensioner	14510-5A2-A01	1
Cam Chain Auto-Tensioner filter	14560-5A2-A00	1
Oil Filter	15400-PLM-A01	1

REQUIRED MATERIALS

Part Name	Part Number	Quantity
Full Synthetic Engine Oil, 0W20 (one quart will top off about four vehicles)	08798-9063	1
HondaBond 4 (one tube will repair about 20 vehicles)	08717-1194	1

CUSTOMER INFORMATION: The information in this bulletin is intended for use only by skilled technicians who have the proper tools, equipment, and training to correctly and safely maintain your vehicle. These procedures should not be attempted by "do-it-yourselfers," and you should not assume this bulletin applies to your vehicle, or that your vehicle has the condition described. To determine whether this information applies, contact an authorized Honda automobile dealer.

WARRANTY CLAIM INFORMATION

The normal warranty applies.

Operation Number	Description	Flat Rate Time	Template ID	Failed Part Number
110114	Replace the cam chain tensioner and install a tensioner filter.	0.6 hour	14-030A	14510-5A2-A01

Defect Code: 01801

Symptom Code: 04201

Skill Level: Repair Technician

REPAIR PROCEDURE

1. Remove the right front wheel.
2. Remove the engine undercover.
3. Remove the chain case cover.

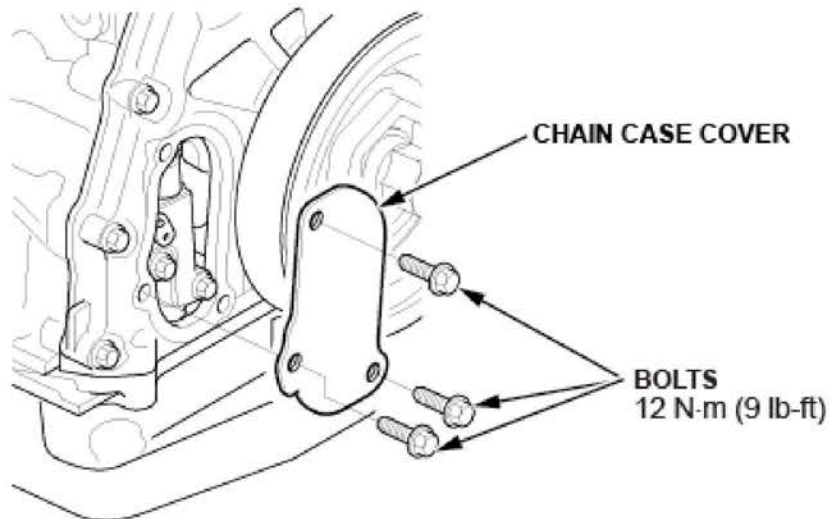

4. Clean the chain case cover and the chain case.

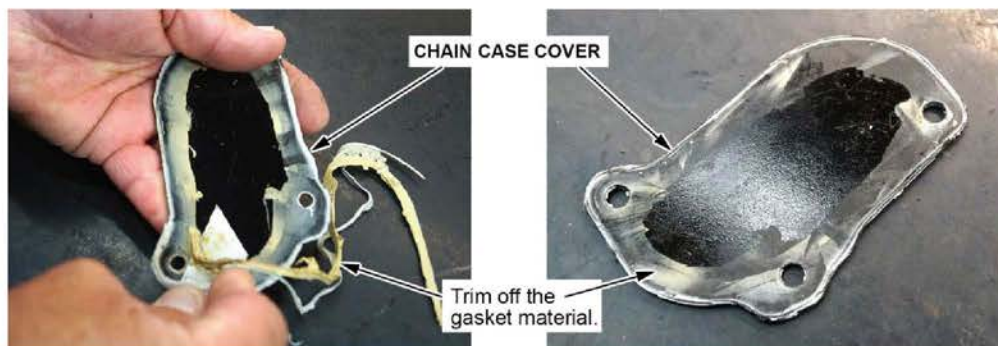

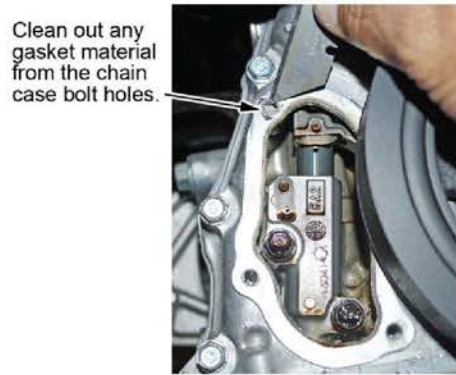

- Turn the crankshaft counterclockwise until the cam chain auto-tensioner is compressed.

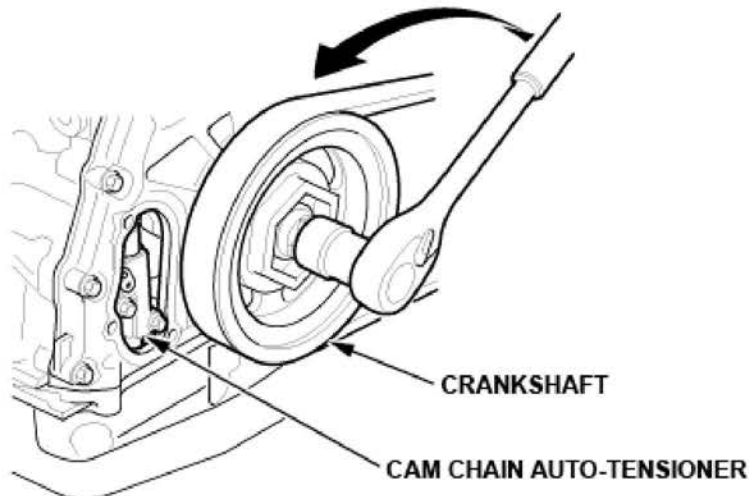

- Remove the cam chain auto-tensioner.

NOTE: Use a 1.2 mm diameter pin, a large paper clip, or similar item to hold the auto-tensioner arm in a locked position for removal.

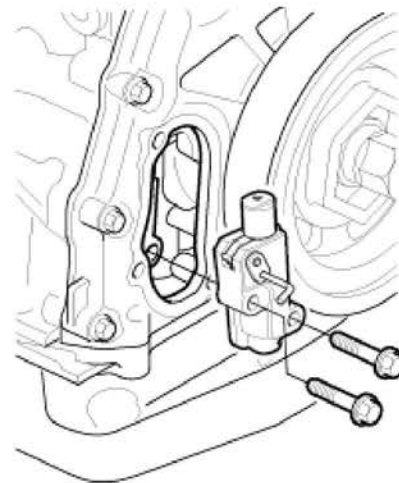
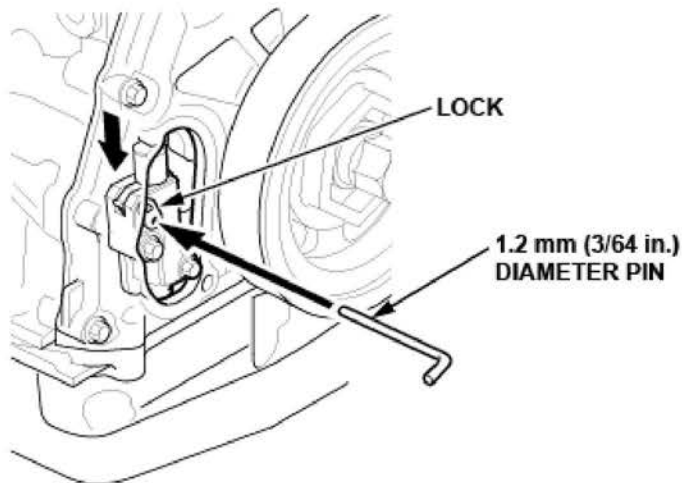

- Remove the oil filter.
- Place a shop towel over the place on the engine block where the cam chain auto-tensioner mounts.
- Using shop air, place the air nozzle into the oil filter mounting adapter.

OIL FILTER MOUNTING ADAPTER COMPRESSED AIR



10. Blow compressed air for 5 seconds through the oil passage to clear any debris before installing the new cam chain auto-tensioner.

Blow air for 5 seconds.



11. Install new a oil filter.
12. Install the cam chain auto-tensioner filter onto the new cam chain auto-tensioner.

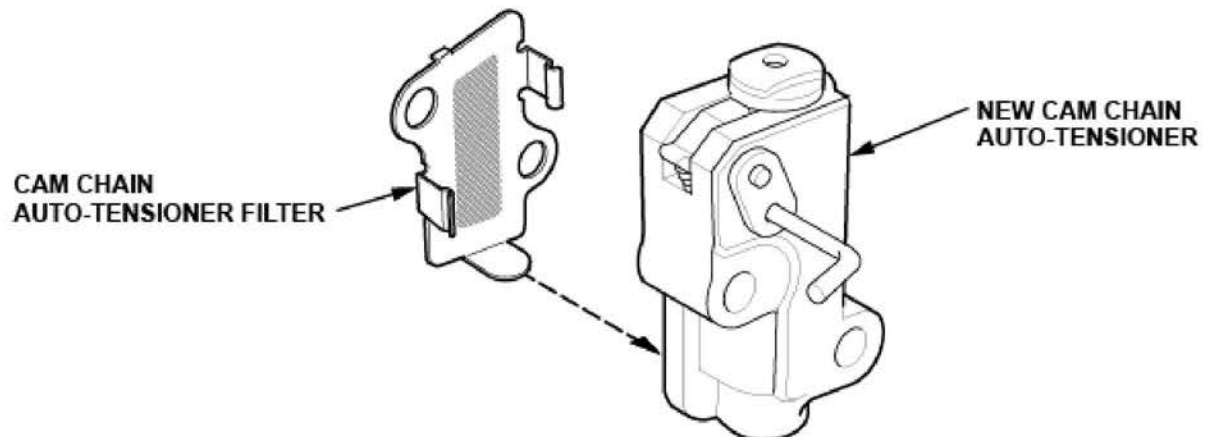

13. Install the new cam chain auto-tensioner with filter, and torque the bolts to **12 N·m (9 lb-ft)**.

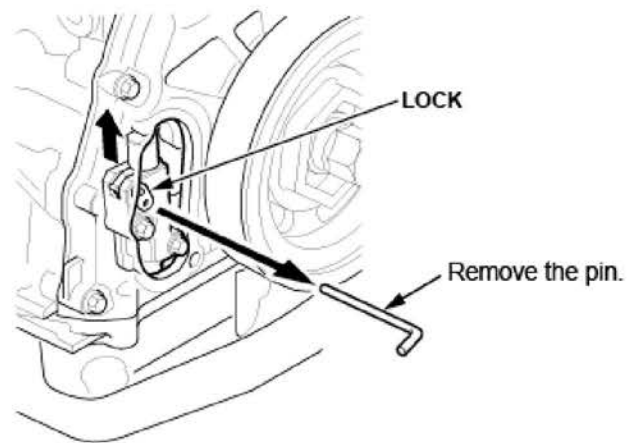
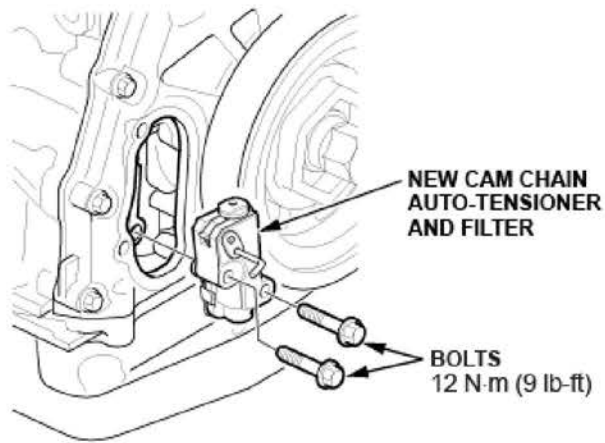

14. Apply a 2.5 mm diameter bead of hondabond 4 along the broken line.

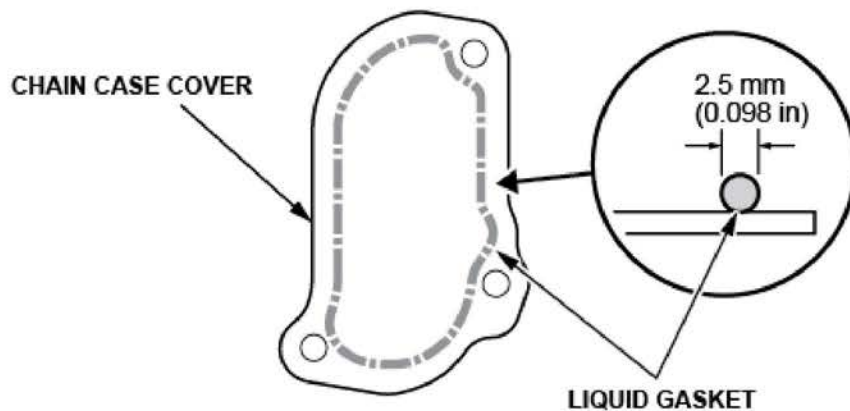

15. Install the chain case cover and torque the bolts to **12 N·m (9 lb-ft)**.
16. Install the engine undercover.
17. Install the right front wheel and torque the nuts to **108 N·m (80 lb-ft)**.
18. Top off the engine oil level.
19. Start the engine, warm up to operating temperature, and check for leaks.