

- ATTENTION:**
- GENERAL MANAGER
 - PARTS MANAGER
 - CLAIMS PERSONNEL
 - SERVICE MANAGER

IMPORTANT - All Service Personnel Should Read and Initial in the boxes provided, right.

© 2022 Subaru of America, Inc. All rights reserved.



QUALITY DRIVEN® SERVICE

PRODUCT CAMPAIGN BULLETIN

APPLICABILITY: 2022 MY Outback 2.4L (turbo)

NUMBER: WRC-22

SUBJECT: Safety Recall - Engine Harness and ECM replacement

DATE: 07/06/22

NHTSA ID: 22V-473

INTRODUCTION:

Subaru of America, Inc. (Subaru) is initiating a new safety recall for certain 2022 model year Outback vehicles equipped with a 2.4L turbo engine, which may contain damage to the engine wiring harness.

DESCRIPTION OF THE DEFECT AND SAFETY RISK

Due to a deformed terminal on an engine test harness used during vehicle production, the engine wiring harness in the affected vehicles may contain a damaged female terminal. A damaged female terminal may result in poor contact with the male terminal of the engine control unit (ECU). If the terminals lose connection while driving, the vehicle may experience a complete loss of motive power without the ability to restart, increasing the risk of a crash.

Remedy

The engine wiring harness and ECM will be replaced at no cost to the customer.

Affected Vehicles

A total of 15 U.S. Outback vehicles will be affected by this recall, as listed below:

Model Year	Carline	Production Date Range
2022	Outback (turbo)	May 3, 2022 – May 5, 2022

Not all vehicles in the production range listed above are affected by this recall. Coverage must be confirmed by using the Vehicle Coverage Inquiry function on subarunet.com prior to repair. This information is now available.

<p>CAUTION: VEHICLE SERVICING PERFORMED BY UNTRAINED PERSONS COULD RESULT IN SERIOUS INJURY TO THOSE PERSONS OR TO OTHERS.</p> <p>Subaru Service Bulletins are intended for use by professional technicians ONLY. They are written to inform those technicians of conditions that may occur in some vehicles, or to provide information that could assist in the proper servicing of the vehicle. Properly trained technicians have the equipment, tools, safety instructions, and know-how to do the job correctly and safely. If a condition is described, DO NOT assume that this Service Bulletin applies to your vehicle, or that your vehicle will have that condition.</p>	<p>Subaru of America, Inc. is ISO 14001 Compliant</p> <p>ISO 14001 is the international standard for excellence in Environmental Management Systems. Please recycle or dispose of automotive products in a manner that is friendly to our environment and in accordance with all local, state and federal laws and regulations.</p>
--	--

Continued...

Retailer Responsibility

Please be advised that it is a violation of Federal law for a dealer to deliver a new motor vehicle covered by a recall under a sale or lease until the defect is remedied. Therefore, any Authorized Subaru Retailer failing to perform the applicable service procedures to correct all affected vehicles in their inventory prior to the vehicle being placed in service may be subject to civil penalties of up to \$22,423 per violation (i.e., for each vehicle), as provided in 49 CFR §578.6 and will also be in breach of the Subaru Dealer Agreement.

Any vehicles listed in any recall/campaign that are in retailer stock must be:

- Immediately identified
- Tagged or otherwise marked to prevent their delivery or use prior to repair
- Repaired in accordance with the repair procedures outlined in the Product Campaign Bulletin

Retailers are to promptly perform the applicable service procedures, to correct all affected vehicles in their inventory (used, demo & SSLP). Whenever a vehicle subject to this recall is taken into retailer inventory necessary steps should be taken to ensure the recall correction has been made before selling or releasing the vehicle.

Owner Notification

Subaru will notify affected vehicle owners by first class mail within 60 days. Retailers will be advised when the notification is scheduled.

PART INFORMATION:

REMINDER: Always order the most up-to-date replacement parts based on the specific VIN being repaired.

Model	Part Description	Part Number
Outback	UNIT-EGI CONTROL	22765AR991
	HARN-ENG	24020AG73A
Outback Wilderness	UNIT-EGI CONTROL	22765AR251
	HARN-ENG	24020AH21A

IMPORTANT: The engine harnesses and engine control units required for this repair are on hold, due to the limited scope of this recall. Retailers must contact the PICs with the affected VIN for release.

One-Time Use Parts		
Part Description	Part Number	Quantity
GSKT-INT MANIF	14035AA74A	2
GSKT-EGR PIPE	14738AA29A	1
GSKT-THROT CHMBR	16175AA53A	1
GSKT-AIR INT DUCT	14497AA070	1
GSKT-AIR INT DUCT	14497AA080	1
GSKT-INTER COOLER	21896AA130	1
GSKT-EGR PIPE	14738AA340	1

Continued...

SERVICE PROCEDURE / INFORMATION:

REMINDER: Customer satisfaction and retention starts with performing quality repairs.

CRITICAL: There are added tips and warnings provided below within the service procedure. It is **IMPORTANT** to read **ALL** the information below fully before proceeding to prevent any damage to the engine electrical system components.

CAREFULLY replace the engine wiring harness **FIRST** following the additional tips below **in conjunction with the procedure in the applicable Service Manual: Engine > FUEL INJECTION (FUEL SYSTEMS)(H4DOTC) > Engine Wiring Harness.**

CRITICAL: NEVER INSTALL THE NEW ENGINE WIRING HARNESS CONNECTIONS TO THE ORIGINAL ECM. DOING SO WILL LIKELY DAMAGE THE NEW WIRE HARNESS TERMINAL CONNECTIONS.

CAREFULLY replace the ECM following the procedure in the applicable Service Manual: **Engine > FUEL INJECTION (FUEL INJECTION (FUEL SYSTEMS)(H4DOTC) > Engine Control Module.**

- **ALWAYS** confirm the connector levers are in the fully locked position. See images below.

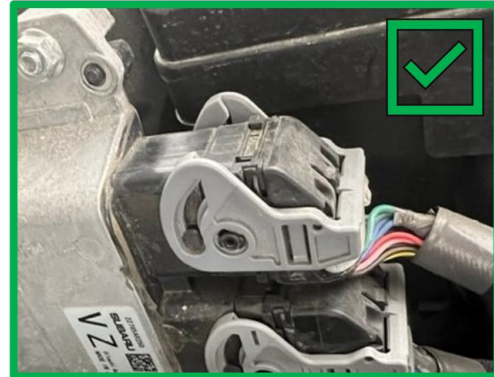
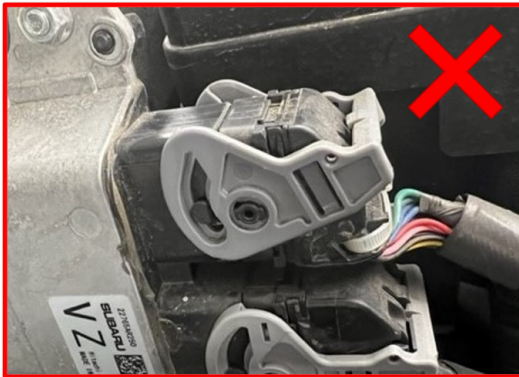

- **ALWAYS** perform the “Entry VIN” procedure using SSM.

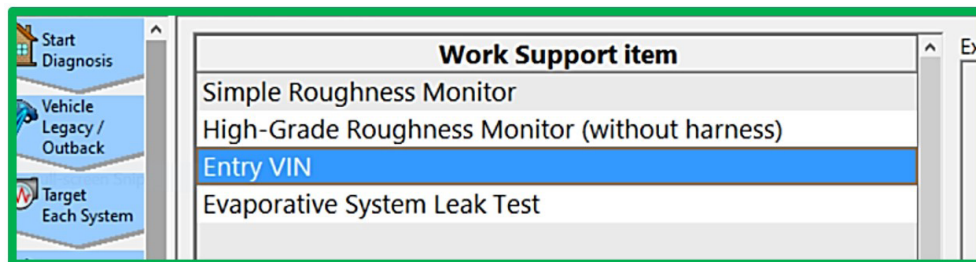

- **ALWAYS** perform immobilizer registration when the ECM is replaced. Information regarding

Continued...

immobilizer related procedure information can be found in **TSB 15-246-19R**. More detailed instructions for performing all immobilizer-related functions can be found on STIS under the Other/Miscellaneous Publication Type: “20MY Registration Manual for Immobilizer” or by searching Document Code: S1108BE.

IMPORTANT REMINDER: NEVER INSTALL THE NEW ENGINE WIRING HARNESS CONNECTIONS TO THE ORIGINAL ECM. DOING SO WILL LIKELY DAMAGE THE NEW WIRE HARNESS TERMINAL CONNECTIONS.

ADDITIONAL NOTES:

- When reconnecting the ground cable terminal to the battery sensor, torque to 7.5Nm (5.5ft.-lbs. or 66inch-lbs.) while supporting the sensor with the other hand as outlined in the applicable Service Manual under: STARTING/CHARGING SYSTEMS > Battery Sensor.
- Refer to the applicable Service Manual and review: General Description > Repair Contents > Action required before & after Battery Disconnect. Additionally, record any stored seat position(s) before proceeding. Relearn any seat position memory after work is complete. If the power rear gate (PRG) height has been customized, the position must also be noted and relearned.

SERVICE PROCEDURE TIPS:

The Subaru Service Manual does not describe the procedures shown in the photos below. The harness can be removed with less difficulty when following the guided tips provided below. **Review these tips in their entirety before** proceeding with any work procedures.

TIP 1) Remove the battery from the vehicle.

TIP 2) Remove the two bolts securing the engine oil cooler pipe. DO NOT remove the water hose. This eliminates engine coolant loss.

NOTE: The lower bolt can be removed easily with the vehicle on a lift.

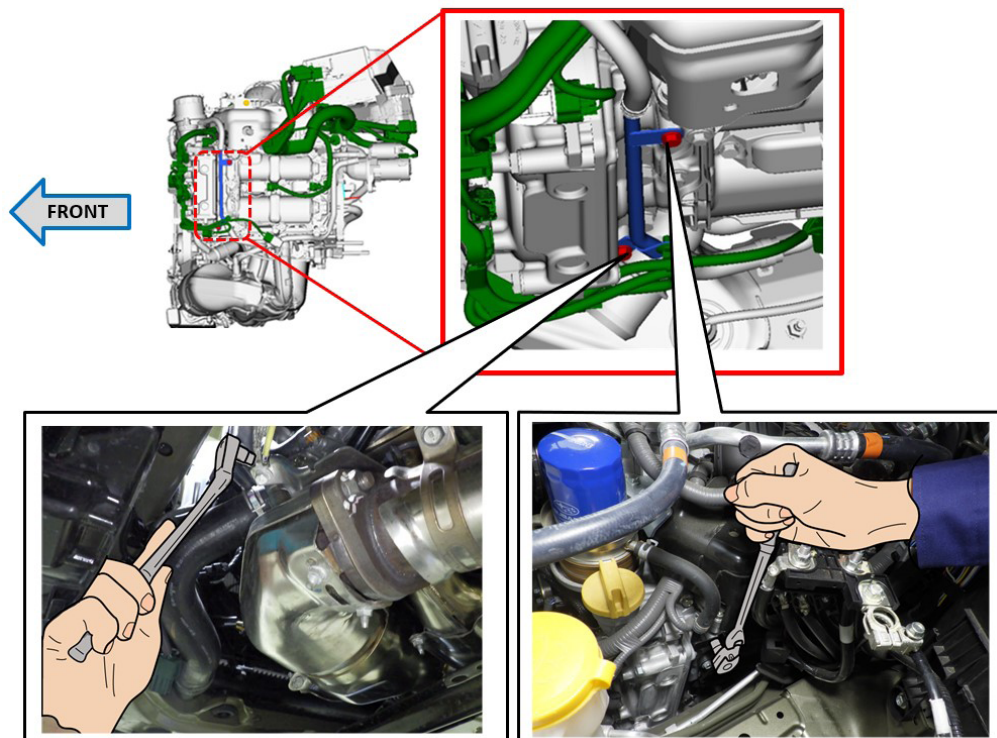

Continued...

TIP 3) It is not necessary to remove the entire PCV pipe. Detach the pipe from the holding clamp. This will avoid replacement of the PCV pipe which is a one-time use part.

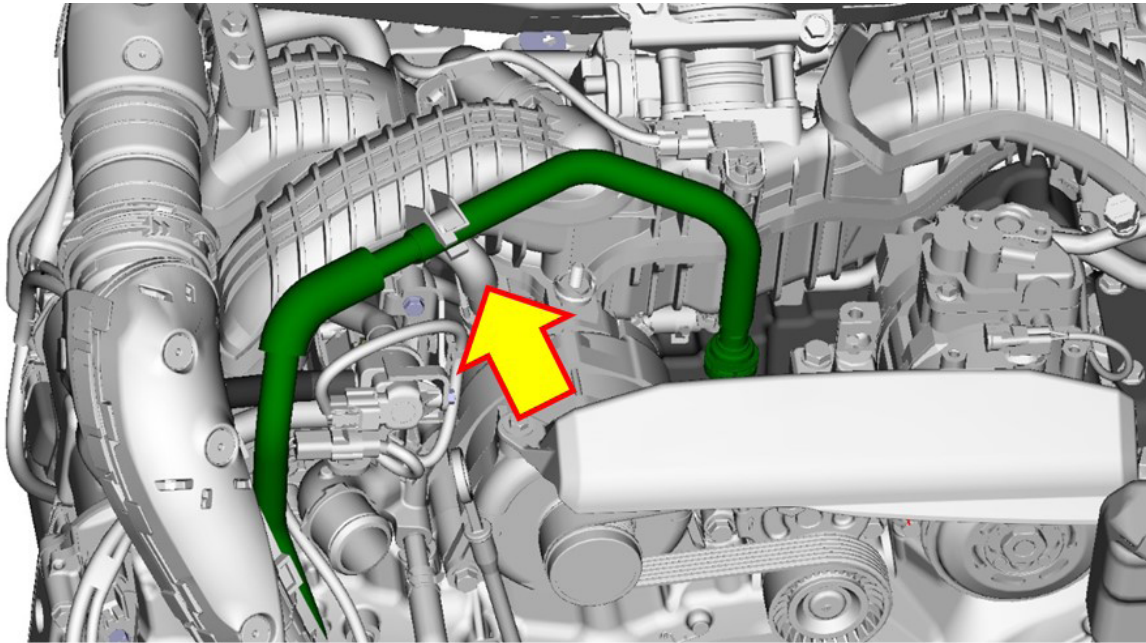

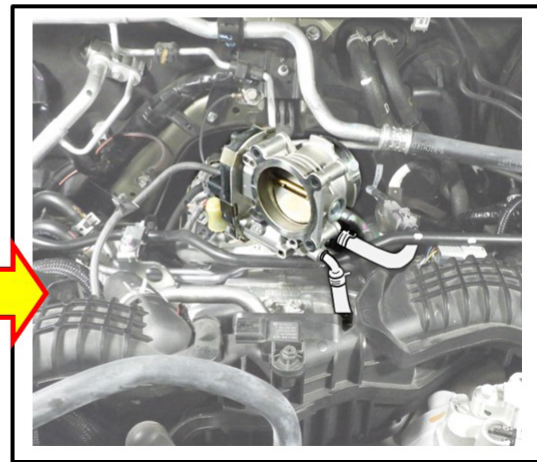
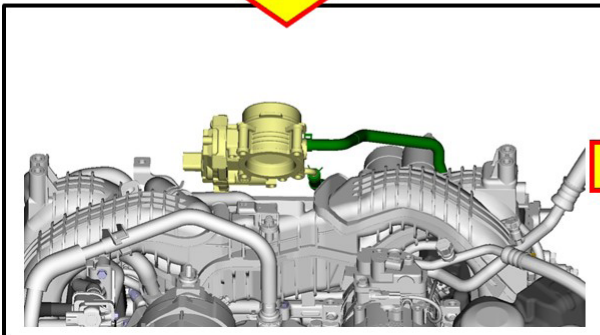
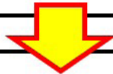
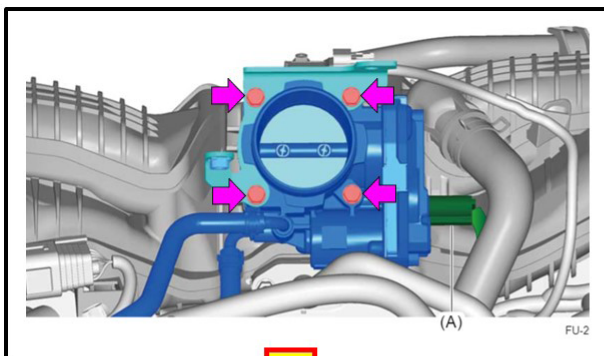

TIP 4) The throttle body assembly does not have to be fully removed. Remove the four mounting bolts and disconnect the wiring harness connection. The throttle body assembly can be repositioned with the pre-heater (coolant) hoses attached to gain sufficient access. Use CAUTION to not damage the throttle plate during this procedure.

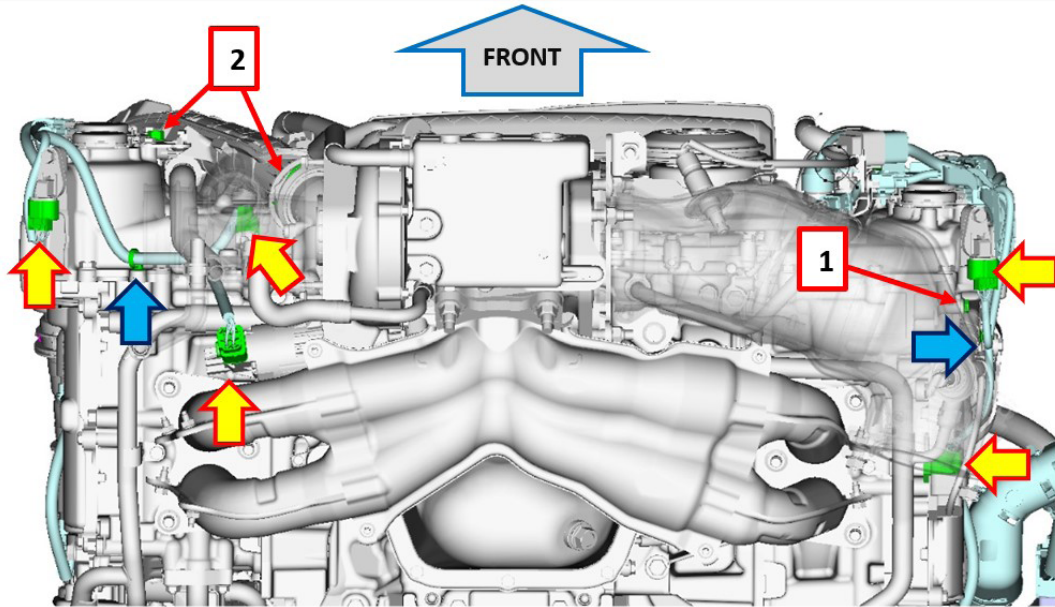

Continued...

TIP 5) CAREFULLY raise the vehicle and disconnect the five electrical connectors and the harness mounting clips. Remove the mounting bolt and the spring lock on the intake duct. Refer to the images below.



- 1** Lower Oil Cooler Pipe Mounting Bolt
- 2** Mounting Bolt and Spring Lock for the Intake Duct
-  Electrical Connectors
-  Harness Mounting Clips

Left Side View

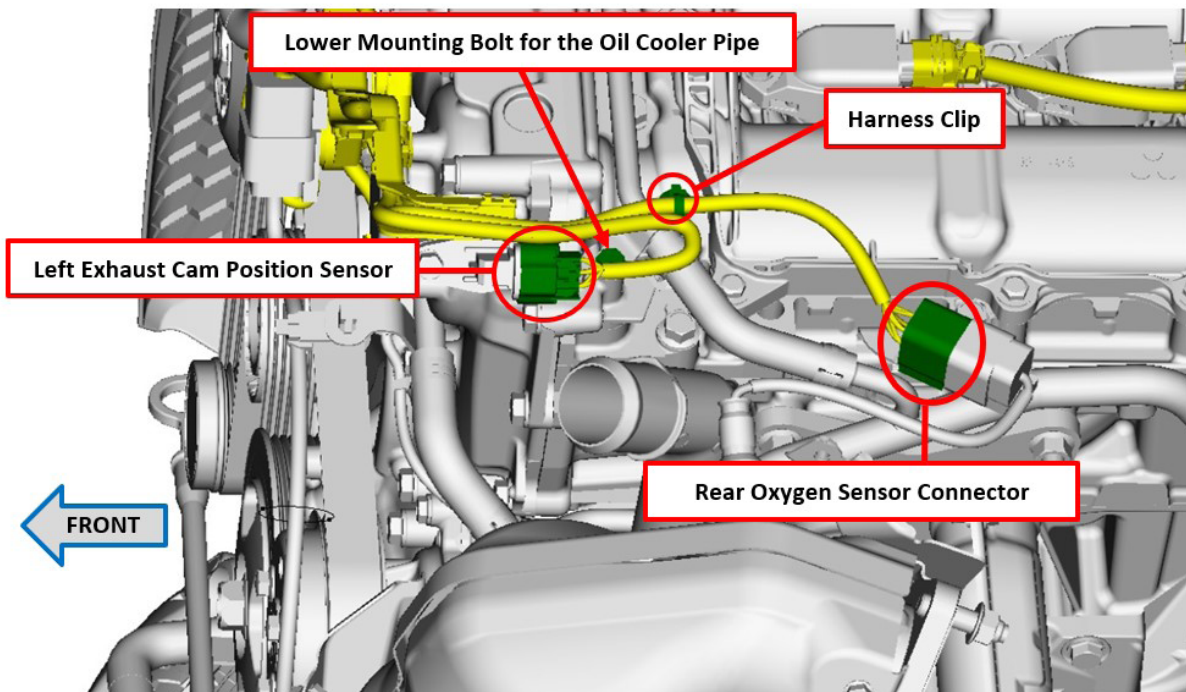

Continued...

Right Side View

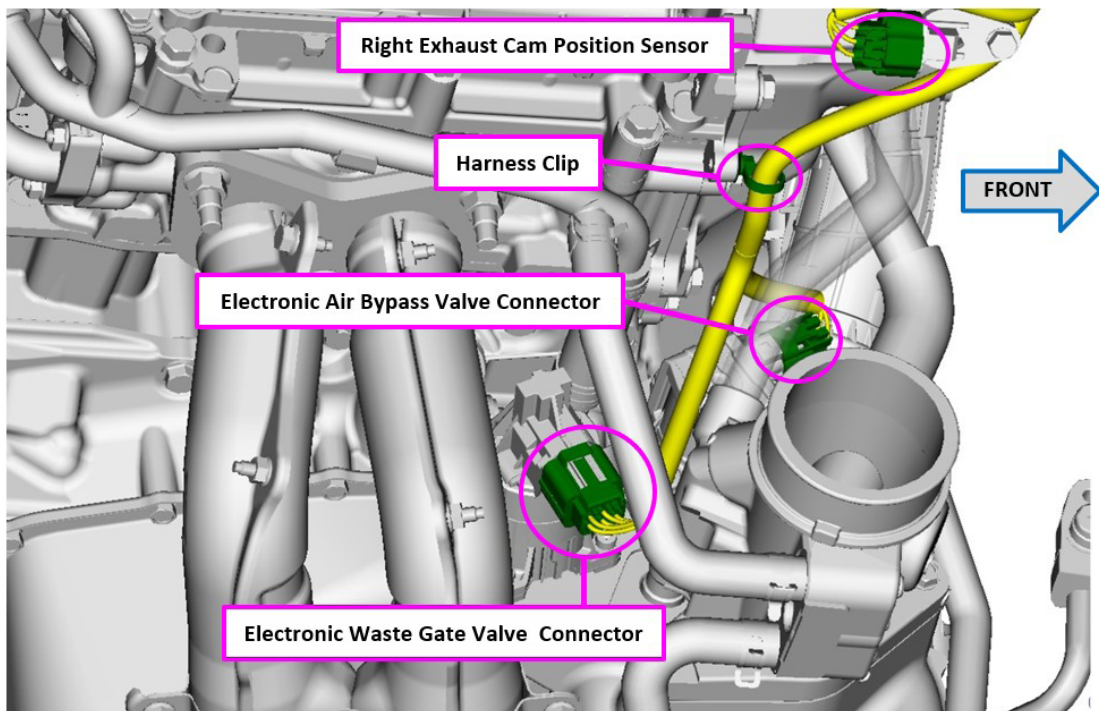

Intake Duct View

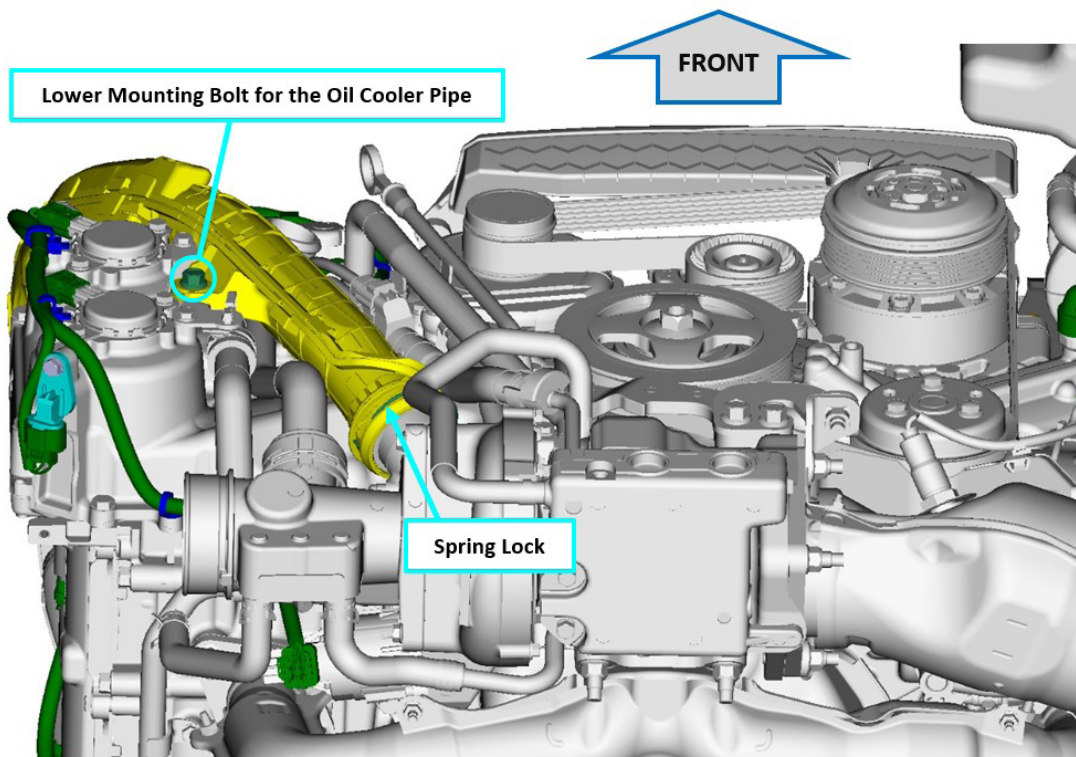

Continued...

ADDITIONAL PROCEDURE INFORMATION:

- Reassemble all removed components in the reverse order of disassembly.
- **REMINDER-** reconnect the ECM and EGI harness **ONLY AFTER BOTH** have been replaced.
- When reconnecting the positive battery terminal, torque to 6Nm (2.6ftlbs. or 53.1 inch-lbs.). When reconnecting the ground cable terminal to the battery sensor, torque to 7.5Nm (5.5ft.-lbs. or 66inch-lbs.) while supporting the sensor with the other hand as outlined in the applicable Service Manual under: STARTING/CHARGING SYSTSEMS > Battery Sensor.

SERVICE PROGRAM IDENTIFICATION LABEL:

Type or print the necessary information on a Campaign Identification Label. The completed label should be attached to the vehicle's upper radiator support. Additional labels are available through normal parts ordering channels. The part number is **MSA6P1302**, which comes as one sheet of 20 labels.

Part Number	Applicability	Description	Order Quantity
MSA6P1302	All Models	Campaign Completion Labels (contains one sheet of 20 labels)	1

SUBARU
Campaign Code
WRC-22
COMPLETED
DIST./DEALER NO.
SERIAL NO.
DO NOT REMOVE

CLAIM REIMBURSEMENT AND ENTRY PROCEDURES:

Credit to perform this recall will be based on properly completed repair order information. Retailers may submit claims through Subarunet.com.

Model	Description	Labor Operation #	Labor Time	Fail Code #	Claim Type
All	Engine Wiring Harness & ECM Replacement	A180-155	2.7H	WRC-22	RC

IMPORTANT REMINDERS:

- SOA strongly discourages the printing and/or local storage of service information as previously released information and electronic publications may be updated at any time.
- Always check for any open recalls or campaigns anytime a vehicle is in for servicing.
- Always refer to STIS for the latest service information before performing any repairs.